



УНИВЕРЗИТЕТ У НИШУ  
ФАКУЛТЕТ ЗАШТИТЕ НА РАДУ У НИШУ  
UNIVERSITY OF NIŠ  
FACULTY OF OCCUPATIONAL SAFETY



# OESEEM

19<sup>th</sup> INTERNATIONAL CONFERENCE  
"MAN AND WORKING ENVIRONMENT"

OCCUPATIONAL AND ENVIRONMENTAL SAFETY  
ENGINEERING & MANAGEMENT



## *Conference Proceedings*

SERBIA - NIŠ  
NOVEMBER 24 - 25, 2022.





**UNIVERSITY OF NIŠ  
FACULTY OF OCCUPATIONAL SAFETY**

The 19<sup>th</sup> International Conference “Man and Working Environment”  
**OCCUPATIONAL AND ENVIRONMENTAL SAFETY ENGINEERING  
&  
MANAGEMENT**

**CONFERENCE PROCEEDINGS**

*Ministry of Education, Science and Technological Development of the Republic of Serbia*

24-25, November 2022  
Niš, Serbia

**The 19th International Conference “Man and Working Environment”  
OCCUPATIONAL AND ENVIRONMENTAL SAFETY ENGINEERING  
&  
MANAGEMENT**

**Conference Organiser:**  
UNIVERSITY OF NIŠ  
FACULTY OF OCCUPATIONAL SAFETY

**Conference Co-organisers:**  
Faculty of Engineering, University of Porto, Portugal  
Faculty of Management, University of Primorska, Koper, Slovenia  
Mechanical Engineering Faculty, University of Slavonski Brod, Croatia

**Publisher:**  
University of Niš, Faculty of Occupational Safety

**For the publisher:**  
Prof. Dr. Srđan Glišović, Dean

**Editors:**  
Prof. Dr. Vesna Nikolić  
Prof. Dr. Evica Stojiljković

**Technical Editor:**  
Rodoljub Avramović, MSc

**Proofreading:**  
Prof. Predrag Niketić, PhD  
Aleksandra Petković, MA

**Printout:**  
“Unigraf X-copy“ doo Niš

**Number of copies: 100**

CIP - Каталогизacija у публикацији  
Народна библиотека Србије, Београд

331.45/.46(082)  
502/504(082)  
614.8.084(082)

**INTERNATIONAL Conference Man and Working Environment (19 ; 2022 ; Niš)**

Occupational and environmental safety engineering & management : conference proceedings / The 19th International Conference “Man and Working Environment”, 24-25, November 2022 Niš ; [conference organiser] Faculty of occupational safety ... [et al.] ; [editors Vesna Nikolić, Evica Stojiljković]. - Niš : Faculty of Occupational Safety, 2022 (Niš : Unigraf X-copy). - 366 str. : ilustr. ; 30 cm

Tekst štampan dvostubačno. - Na nasl. str.: Ministry of Education, Science and Technological Development of the Republic of Serbia. - Tiraž 100. - Bibliografski podaci o autorima uz svaki rad. - Bibliografija uz svaki rad.

ISBN 978-86-6093-112-4

а) Заштита на раду -- Зборници б) Животна средина -- Заштита -- Зборници в)  
Превентивно инжењерство -- Зборници

COBISS.SR-ID 82487561



**Conference Organiser:**

**UNIVERSITY OF NIŠ**



**FACULTY OF OCCUPATIONAL SAFETY**



**Conference Co-organisers:**

**Faculty of Engineering, University of Porto, Portugal**



**Faculty of Management, University of Primorska, Koper, Slovenia**



**Mechanical Engineering Faculty, University of Slavonski Brod, Croatia**



**UNDER THE AUSPICES OF:**

**Ministry of Education, Science and Technological Development of the Republic of Serbia**



Република Србија

Министарство просвете,  
науке и технолошког развоја

[www.mpn.gov.rs](http://www.mpn.gov.rs)





## SCIENTIFIC COMMITTEE

**Srdan Glišović, PhD, Chairman**

University of Niš, Faculty of Occupational Safety, Serbia

**Miomir Raos, PhD, Vice-chairman**

University of Niš, Faculty of Occupational Safety, Serbia

**João Manuel Abreu dos Santos Baptista, PhD, Vice-chairman**

University of Porto, Faculty of Engineering, Portugal

**Tatjana Horvat, PhD, Vice-chairman**

University of Primorska, Faculty of Management, Koper, Slovenia

**Goran Šimunović, PhD, Vice-chairman**

University of Slavonski Brod, Faculty of Mechanical Engineering, Croatia

**Mário Vaz, PhD**

University of Porto, Faculty of Engineering, Portugal

**Luis Gimeno, PhD**

University of Vigo, Faculty of Sciences, Spain

**Raquel Nieto, PhD**

University of Vigo, Faculty of Sciences, Spain

**Saša Kenjereš, PhD**

Delft University of Technology, Faculty of Applied Sciences, The Netherlands

**Ivan Samardžić, PhD**

University of Slavonski Brod, Faculty of Mechanical Engineering, Croatia

**Dejan Mirakovski, PhD**

University "Goce Delčev", Faculty of Natural and Technical Sciences Štip, North Macedonia

**Dame Dimitrovski, PhD**

University of Skopje, Faculty of Mechanical Engineering, North Macedonia

**Zorana Tanasić, PhD**

University of Banja Luka, Faculty of Mechanical Engineering, Bosnia and Herzegovina

**Darko Petković, PhD**

University of Zenica, Faculty of Mechanical Engineering, Bosnia and Herzegovina

**Mirjana Vojinović-Miloradov, Professor Emeritus**

University of Novi Sad, Faculty of Technical Sciences, Serbia

**Miodrag Hadžistević, PhD**

University of Novi Sad, Faculty of Technical Sciences, Serbia

**Dragan Mladan, PhD**

University of Criminal Investigation and Police Studies, Department of Criminology, Serbia

**Zoran Keković, PhD**

University of Belgrade, Faculty of Security Studies, Serbia

**Dragan Pamučar, PhD**

University of Defence in Belgrade, Serbia

**Danijela Ristic-Durrant, Dr.ing.**

University of Bremen, Institute of Automation (IAT), Germany

**Lazar Velimirović, PhD**

Mathematical Institute of the Serbian Academy of Sciences and Arts, Serbia

**Milan Banić, PhD**

University of Niš, Faculty of Mechanical Engineering, Serbia

**Petar Todorov Todorov, PhD**

Academy of the Ministry of Interior, Faculty of Fire Safety and Civil Protection, Bulgaria

## **PROGRAMME COMMITTEE**

**Mirko Markič, PhD**

University of Primorska, Faculty of Management, Koper, Slovenia

**Maja Meško, PhD**

University of Primorska, Faculty of Management, Koper, Slovenia

**Marija Hadži-Nikolova, PhD**

University “Goce Delčev”, Faculty of Natural and Technical Sciences, Štip, North Macedonia

**Joana Guedes, PhD**

University of Porto, Faculty of Engineering, Portugal

**Biljana Vranješ, PhD**

University of Banja Luka, Faculty of Mechanical Engineering, Bosnia and Herzegovina

**Emina Hadžić, PhD**

University of Sarajevo, Faculty of Civil Engineering, Bosnia and Herzegovina

**Džafer Dautbegović, PhD**

University of Zenica, Faculty of Mechanical Engineering, Bosnia and Herzegovina

**Dragan Adamović, PhD**

University of Novi Sad, Faculty of Technical Sciences, Serbia

**Aleksandar Žunjić, PhD**

University of Belgrade, Faculty of Mechanical Engineering, Serbia

**Svetlana Čičević, PhD**

University of Belgrade, Faculty of Transport and Traffic Engineering, Serbia

**Slaviša Trajković, PhD**

University of Niš, Faculty of Civil Engineering and Architecture, Serbia

**Jovica Jovanović, PhD**

University of Niš, Faculty of Medicine, Serbia

**Milan Blagojević, PhD**

University of Niš, Faculty of Occupational Safety, Serbia

**Momir Praščević, PhD**

University of Niš, Faculty of Occupational Safety, Serbia

**Tatjana Golubović, PhD**

University of Niš, Faculty of Occupational Safety, Serbia

**Dejan Krstić, PhD**

University of Niš, Faculty of Occupational Safety, Serbia

**Ivan Krstić, PhD**

University of Niš, Faculty of Occupational Safety, Serbia

**Vesna Miltojević, PhD**

University of Niš, Faculty of Occupational Safety, Serbia

**Josip Taradi, PhD**

European Society of Safety Engineers, Zagreb, Croatia

**Petar Vranić, PhD**

Mathematical Institute of the Serbian Academy of Sciences and Arts, Serbia

**Aleksandra Živković, PhD**

Heinrich Heine University Düsseldorf, Institute for Pharmaceutical and Medicinal Chemistry, Germany

**Radoslav Hristov Kartov, PhD**

Academy of the Ministry of Interior, Faculty of Fire Safety and Civil Protection, Bulgaria



## **ORGANISING COMMITTEE**

**Vesna Nikolić, PhD, Chairman**

University of Niš, Faculty of Occupational Safety, Serbia

**Evica Stojiljković, PhD, Vice-chairman**

University of Niš, Faculty of Occupational Safety, Serbia

**Dejan Vasović, PhD**

University of Niš, Faculty of Occupational Safety, Serbia

**Aleksandra Ilić Petković, PhD**

University of Niš, Faculty of Occupational Safety, Serbia

**Predrag Niketić, PhD**

University of Niš, Faculty of Occupational Safety, Serbia

**Tamara Vukić, MA**

University of Niš, Faculty of Occupational Safety, Serbia

**Joana Duarte, PhD**

IJOES, University of Porto, Portugal

**Danijela Avramovic, PhD**

University of Niš, Faculty of Occupational Safety, Serbia

**Aleksandra Petković, MA**

University of Niš, Faculty of Occupational Safety, Serbia

**Rodoljub Avramović, MSc**

University of Niš, Faculty of Occupational Safety, Serbia

**Mirjana Milutinović, MSc**

University of Niš, Faculty of Occupational Safety, Serbia

**Dejan Ristić, MSc**

University of Niš, Faculty of Occupational Safety, Serbia



# CONTENTS

---

## INVITED LECTURES

<b>Mirjana Vojinović-Miloradov, Miljan Šunjević</b> THE FANTASTIC ICOSAHEDRON ARCHITECTURE OF LIQUID WATER: THE KEY CONCLUSIONS OF THE IPA INTERREG PROJECT .....	19
<b>Mirko Markič</b> MODERN CONCEPTS OF SAFETY MANAGEMENT SYSTEMS .....	25
<b>Saša Kenjereš</b> COMPUTATIONAL FLUID DYNAMICS AND ATMOSPHERIC CHEMISTRY FOR PREDICTIONS OF A CITY POLLUTION .....	31
<b>Joana Duarte, Jacqueline Castelo Branco, Fernanda Rodrigues, João Santos Baptista</b> SURFACE MINING ENVIRONMENTAL IMPACTS AND THEIR MANAGEMENT– A SHORT REVIEW .....	39

---

## OCCUPATIONAL SAFETY ENGINEERING AND MANAGEMENT

<b>Monika Lutovska, Vladimir Mijakovski</b> OCCUPATIONAL SAFETY AND HEALTH STATISTICS WITHIN THE SUSTAINABILITY AGENDA .....	47
<b>Adeeb Sidani, João Poças Martins, Alfredo Soeiro</b> INVESTIGATING BIM-BASED CONSTRUCTION SAFETY EDUCATION TECHNIQUES .....	51
<b>Bojana Zoraja, Miodrag Živančev, Bojana Tot</b> OCCUPATIONAL SAFETY RISK ASSESSMENT MODEL IN THE WASTE MANAGEMENT SECTOR .....	55
<b>Bojana Tot, Goran Vujić, Dragan Adamović</b> TRAINING MODULE FOR WASTE MANAGEMENT WORKERS .....	61
<b>Uglješa Jovanović, Dejan Krstić, Darko Zigar, Jelena Malenović-Nikolić</b> IMPACT OF MOBILE PHONE PITCH AND ROLL ANGLES ON SAR DISTRIBUTION IN A HUMAN HEAD .....	65
<b>Nikola Šobat, Mile Vajkić, Biljana Vranješ, Lutvo Haznadarević</b> ANALYSIS OF SAFETY MEASURES DURING THE REFILLING OF LIQUID HAZARDOUS SUBSTANCES - CASE STUDY .....	71
<b>Tatjana Golubović, Ana Bijelić</b> BROMINATED FLAME RETARDANTS: OCCUPATIONAL EXPOSURE AND TOXICITY .....	77
<b>Bojan Bijelić, Evica Stojiljković</b> OBSERVATIONAL METHODS FOR ERGONOMIC RISK ASSESSMENT IN DENTAL PRACTICE .....	85
<b>Miodrag Živančev, Bojana Zoraja, Dejan Ubavin, Dušan Milovanović</b> OCCUPATIONAL HEALTH & SAFETY RISKS IN MATERIAL RECOVERY FACILITIES .....	91

<b>Aleksandra Ilić Petković</b> THE IMPACT OF DIGITALIZATION ON NEW FORMS OF WORK AND PROTECTION OF EMPLOYEES.....	95
<b>Tatiana Ivanova, Irina Kolodiy</b> EMOTIONAL BURNOUT AS THE MAIN FACTOR OF OCCUPATIONAL SAFETY IN MODERN CONDITIONS .....	99
<b>Ana Silva, André Filipe Ferreira da Silva, Raquel Pereira Martins, Olívia Pinho</b> SICK BUILDING SYNDROME (SBS) IN HEALTHCARE WORKERS: A SYSTEMATIC REVIEW OF INTERVENTIONS.....	105
<b>Ivan Mijailović, Aleksandra Ilić Petković</b> PROTECTION OF EMPLOYEES IN CONSTRUCTION INDUSTRY – IN ANTICIPATION OF THE NEW LAW ON OCCUPATIONAL SAFETY AND HEALTH .....	111
<b>Nikola Šukalo, Nebojša Ćurčić</b> FINANCIAL PLANNING FOR ENFORCEMENT AND CONTROL OF OHS PREVENTIVE MEASURES.....	115

---

## ENVIRONMENTAL SAFETY ENGINEERING AND MANAGEMENT

<b>Mirjana Galjak</b> ENVIRONMENTAL MANAGEMENT IN A MODERN ORGANIZATION .....	121
<b>Nikola Igić, Ana Stojković, Nenad Krstić, Dragan Đorđević, Goran Janačković, Ivan Krstić</b> TREND ANALYSIS OF ISO 14001 STANDARD CERTIFICATION AT THE NATIONAL AND INTERNATIONAL LEVEL.....	127
<b>Jovana Topalić Marković, Vladimir Mučenski</b> LEGAL ASPECTS OF THE RISK ASSESSMENT MODEL CREATED FOR WASTEWATER TREATMENT PLANTS.....	133
<b>Milica Stojanović, Rogert Sorí, Guergana Guerova, Raquel Nieto, Evica Stojiljković, Srđan Glišović, Luis Gimeno</b> DROUGHT ASSESSMENT USING GRACE TOTAL WATER STORAGE DEFICIT IN SERBIA .....	137
<b>Ana Bijelić, Tatjana Golubović, Marina Stojanović</b> THE USE OF SAFER SOLVENTS – ONE OF 12 PRINCIPLES OF GREEN CHEMISTRY .....	143
<b>Irma Dervišević, Almin Dervišević, Milica Tomović, Jovana Galjak</b> INADEQUATE WASTE MANAGEMENT AS A CONSTANT THREAT TO THE ENVIRONMENT .....	151
<b>Natalija Petrović, Dejan Vasović, Nemanja Petrović, Sandra Stanković</b> ANALYSIS OF RELEVANT INPUT PARAMETERS FOR LANDFILL LEACHATE MODELING .....	159
<b>Dragan Adamović, Goran Vujić, Savka Adamović</b> PARTICULATE MATTER AT AN OPEN DUMPING SITE .....	165



<b>Ana Vukadinović, Jasmina Radosavljević, Amelija Đorđević, Milan Protić</b> ENERGY PERFORMANCE IMPACT OF PHASE-CHANGE MATERIALS IN FAÇADE WALLS OF RESIDENTIAL BUILDINGS .....	171
<b>Milan Protić, Nikola Mišić, Miomir Raos, Ana Vukadinović</b> APPLICATION OF NEURAL NETWORKS WITH BAYESIAN REGULARIZATION FOR PREDICTING CONSUMERS' HEAT LOAD IN DISTRICT HEATING SYSTEMS .....	179
<b>Ana Stojanović, Dejan Vasović</b> BENCHMARKING TECHNIQUE FOR EVALUATING THE PERFORMANCE OF PUBLIC UTILITY COMPANIES.....	187
<b>Nikola Mitrović, Milan Đorđević, Sandra Veljković, Danijel Danković</b> DESIGN OF IOT PLATFORM FOR AIR QUALITY MONITORING SYSTEM .....	195
<b>Una Marčeta, Bogdana Vujić, Jelena Vuković</b> IDENTIFICATION OF CRITERIA FOR AIR QUALITY RISK ASSESSMENT ASSOCIATED WITH LANDFILL DUST EMISSION .....	201
<b>Vesna Žikić</b> INTEGRATED ASSESSMENT MODELS IN MODELLING THE WATER-ENERGY-FOOD NEXUS IN SPACE AND TIME .....	205
<b>Vesna Miltojević, Ivana Ilić Krstić</b> ECOLOGICAL AWARENESS OF FEMALE FARMERS AND CLIMATE CHANGE ADAPTATION – A CASE STUDY .....	211
<b>Snežana Živković, Slobodan Milutinović, Tamara Rađenović</b> THE IMPACT OF THE COVID-19 ON THE ENVIRONMENT.....	219
<b>Ljubica Stojković, Dragoslav Pavlović, Ivan Mihajlović</b> ENERGY EFFICIENCY TREATMENT OF WASTE IN THE CITY OF NIŠ .....	225

---

## **FIRE SAFETY ENGINEERING AND DISASTER MANAGEMENT**

<b>Darko Zigar, Dušica Pešić, Milan Blagojević</b> LARGE EDDY SIMULATION OF IMPACT OF VEHICLE NUMBER AND TYPE ON FIRE DYNAMICS IN TUNNELS .....	233
<b>Nadya Kirilova</b> ANALYSIS OF THE ADMINISTRATIVE PENAL ACTIVITY OF THE RDFSCP-PLOVDIV .....	241
<b>Andela Jevtić, Milan Blagojević, Vladimir Stanković, Dejan Ristić, Ivan Garvanov</b> ANALYSIS OF SOFTWARE FOR THE CALCULATION OF STANDBY POWER SUPPLY FOR FIRE ALARM SYSTEMS .....	245
<b>Kiril Hristov, Radoslav Kurtov, Veronika Karadjova</b> ANALYSIS OF LAMINATED PVB GLASSES APPLIED IN THE CONSTRUCTION INDUSTRY.....	251
<b>Vasil Tsanov, Radoslav Kurtov</b> SEMI-EMPIRICAL METHODS FOR DETERMINING CRITICAL TEMPERATURE .....	257

<b>Detelin Spasov, Ivan Todorov</b> EXPERIMENTAL DETERMINATION OF FIRE RESISTANCE OF SUSPENDED CEILINGS.....	261
<b>Nenad Komazec, Katarina Janković</b> MANAGING DISASTER RISK BY DEVELOPING THE RESILIENCE OF LOCAL SELF-GOVERNMENT UNITS.....	265
<b>Tijana Ivanišević, Aleksandar Trifunović, Svetlana Čičević, Aleksandar Žunjić, Vedran Vukšić, Slobodan Mitrović</b> ROAD SAFETY IN ROADWORK ZONES.....	269
<b>Aleksandar Trifunović, Svetlana Čičević, Aleksandar Žunjić, Tijana Ivanišević, Slobodan Mitrović</b> USE OF THE REAR-VIEW MIRROR IN THE VEHICLE FOR DISTANCE PERCEPTION: TRAFFIC SAFETY.....	275
<hr/> <b>SAFETY MANAGEMENT &amp; SUSTAINABLE DEVELOPMENT</b> <hr/>	
<b>Ivana Bogdanović Protić, Ljiljana Vasilevska</b> SUSTAINABLE URBAN AGRICULTURE PRACTICE AND POSSIBILITIES OF ITS APPLICATION IN THE CITY OF NIŠ.....	283
<b>Vesna Nikolić, Tamara Vukić</b> DIDACTIC AND METHODOLOGICAL DISCOURSE OF EDUCATION FOR SUSTAINABLE DEVELOPMENT.....	291
<b>Stanko Stankov</b> SECURITY AND PROTECTION OF SUPERVISORY CONTROL SYSTEMS IN LIGHT OF INDUSTRY 4.0.....	299
<b>Carlo Caiazzo, Aleksandar Đorđević, Marija Savković, Marko Đapan, Arso Vukićević</b> ARCHITECTURE OF HUMAN-ROBOT COLLABORATION IN MANUFACTURING INDUSTRIES.....	307
<b>Dario Javor, Dejan Krstić</b> ENVIRONMENTAL SCHEDULING OF DISTRIBUTED ENERGY SOURCES IN MICROGRIDS.....	315
<b>Kristina Radojević</b> INTEGRATED MANAGEMENT OF SAFETY AND SECURITY – THEORETICAL ASPECTS.....	321
<b>Aleksander Janeš, Ljiljana Bibić, Mirko Markić</b> OVERCOMING BARRIERS – WORKPLACE SAFETY OF PERSONS WITH DISABILITIES.....	327
<b>Danijela Protić, Miomir Stanković</b> RISK MANAGEMENT: MACHINE LEARNING APPROACH TO THE COMPUTER NETWORK SECURITY.....	333
<b>Dušan Tatić, Petar Vranić, Bojan Tešić, Miomir Stanković</b> AN AUGMENTED REALITY-BASED OCCUPATIONAL SAFETY SYSTEM - USERS' EVALUATION.....	339

<b>Bratimir Nešić, Jelena Malenović Nikolić</b> UNUTILIZED ENERGY POTENTIAL OF MSW DEPOSITED AT LESKOVAC SANITARY LANDFILL IN 2021 .....	345
<b>Marija Savković, Nikola Mijailović, Carlo Caiazzo, Marko Đapan, Arso Vukićević</b> ADVANCED PHYSICAL ERGONOMICS AND NEUROERGONOMICS RESEARCH ON AN ASSEMBLY WORKSTATION .....	351
<b>Vladan Ivanović, Jasmina Madžgalj, Olgica Milošević</b> SUSTAINABLE DEVELOPMENT GOALS USED FOR BALANCING SOCIAL, ECONOMIC AND ENVIRONMENTAL SUSTAINABILITY .....	359





# OESEEM

19<sup>th</sup> INTERNATIONAL CONFERENCE  
"MAN AND WORKING ENVIRONMENT"

OCCUPATIONAL AND ENVIRONMENTAL SAFETY  
ENGINEERING & MANAGEMENT

## *Invited Lectures*





MIRJANA VOJINOVIĆ  
MILORADOV<sup>1</sup>  
MILJAN ŠUNJEVIĆ<sup>2</sup>

<sup>1</sup>University of Novi Sad,  
Faculty of Technical Sciences

<sup>1</sup>miloradov@uns.ac.rs

<sup>2</sup>msunjevic@uns.ac.rs

## THE FANTASTIC ICOSAHEDRON ARCHITECTURE OF LIQUID WATER: THE KEY CONCLUSIONS OF THE IPA INTERREG PROJECT

**Abstract:** *The fantastic icosahedron architecture structure of liquid water, nano quant substance is very intriguing, complex, anomalous, and yet not well explored, challenging and mystic. Interconnected networks of the water flickering clusters are the consequence of the vibrating of 4 hydrogen bonds. Although this vibrating water system is in a chaotic state, there is a high level of cluster organization. Twenty of the 14-molecule tetrahedral units may form a 3 nm in diameter of icosahedral structure. The icosahedral (H<sub>2</sub>O)<sub>280/560</sub> network of water clusters is characterized by increased stabilization as the shells increase in order. In a water medium, it is key fact that each chemical compound is enwrapped in aquatic icosahedral clouds. The icosahedral and network structure of (H<sub>2</sub>O)<sub>n</sub> is responsible for the protective water buffer "scaphander" of all polar and non-polar substances, ionic species, molecules, radicals, as well as organic molecules of sugars, proteins, DNA, emergent substances, toxins and xenobiotics (pesticides, pharmaceuticals and others), microbiological agents (bacteria, viruses) and Particulate Matter - PM.*

*The SeNs WETLANDS Project's fundamental pillar is a transnational and interregional collaboration between Croatia (Tompojevački ritovi) and Serbia (lake Zobnatica), with an inter- and trans-disciplinary approach to environmental conservation, with a particular emphasis on protected and vulnerable wetlands. The Project's objectives include enforcing integrated cross-border analytical monitoring of crucial physicochemical parameters and existing threats, as well as biodiversity and the protection of the aquatic and terrestrial environments.*

**Key words:** icosahedron structure of water, water anomalies, mathematical equations, IPA project, water monitoring.

### INSTEAD OF AN INTRODUCTION

The fourth industrial revolution has the potential to improve the quality of life for the whole population and the economy, and form strong links and bonds with the new knowledge, modern education, experiences, and technological innovations in the digital and virtual world domain. Within the Serbian TESLA project, research development and education for the fourth industrial revolution (4IR) are connected to novel composite materials, energy and technology, virtual reality (VR) and artificial intelligence (AI), and other contemporary developments related to sustainable development and circular economy.

In the light of the 4IR, applied AI is the base for exploring the fantastic icosahedron architecture of liquid water and its anomalies. The extensive human population growth and technological development have resulted in an exponential increase in demand and consumption of natural water resources. The issue of

the availability and quality of water is one of the most important but inadmissibly neglected problems of modern society. Temperature rise, floods, changes of relief, biodiversity, and conditions of life and health, at both the global and the local level remain the essential issues and activities for further development of society and civilization.

Water is the most essential and powerful substance on Earth, a technical and biological liquid that is responsible for the origin, development and sustainability of life. Water circulates through the hydrosphere, making the dynamic and reversible hydrological cycle a system of processes necessary for the continued existence of life. Water is the strategic central point and hotspot in the development of every society, all anthropogenic activities, and the sustainability of the environment.

The unique properties of water should not only be observed through its importance for the economy and

strategic developments, but also as an open research platform based on the range of anomalous behaviours and its macroscopic properties. Many unique properties and anomalies of water are the results of the hydrogen bonds and high dipole interaction, due to the electronic structure of oxygen with two free electron pairs. The 4 hydrogen bonds (H-bonds), in addition to the non-directional interactions, result in many unusual physicochemical, structural, dynamic, and thermodynamic characteristics of water, such as increased density while melting, decreased viscosity under pressure, density maximum at 4 °C, high surface tension, and many more (Tao et al., 2017).

There are two exceptional citations that represent the unique, exciting, fantastic and miraculous water in the most beautiful way: “If there is magic on the planet, it is contained in Water” (Loren Eiseley, Immense Journey) and “All the water that will ever be, is right now!” (Greenpeace International).

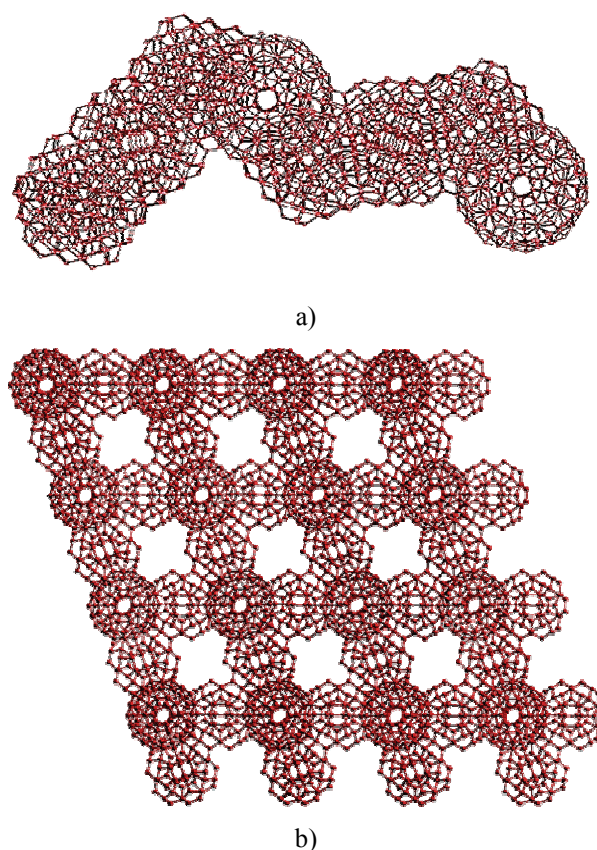
Water from various sources contains dissolved gases, minerals, and organic and inorganic substances that are transferred to water during transformation and passage through lithospheric and pedospheric solid phase and water bodies.

This paper describes the Interreg IPA Interreg IPA CBC Croatia-Serbia Project “Active SEnsor monitoring Network and environmental evaluation for protection and wiSe use of WETLANDS and other surface waters”. The project emerged from the inevitable obligation of expending considerable effort to protect aquatic habitats and the most sensitive and endangered ecological systems. This type of parallel and comparative research was performed for the first time within the Interreg IPA CBC Croatia-Serbia Project AF\_HR-RS135\_SeNs\_Wetlands.

## PORTRAIT OF ICOSAHEDRON STRUCTURE OF LIQUID WATER

The emerging and seemingly ‘magical’ properties of the dynamic and vibrating water network are connected to its ability to form up to 4 H-bonds, tetrahedral symmetry, and dipole interaction, allowing different architectural structures and arrangements. The numerous data from various experiments and simulations have recently become available, four of which are the most interesting (Figures 1, 2, 3) (Palmer et al., 2018; Debenedetti, Sciortino and Zerze, 2020; Tanaka, 2022).

The first one is a super-strand of eight water icosahedrons. Eight complete but overlapping icosahedral clusters form this strand-like structure containing 1750 water molecules (Figure 1a). The second one is the matrix of  $(H_2O)_{100}$  icosahedra as the finest lacy structure of water (Figure 1b).



**Figure 1.** Super-strand of eight water icosahedrons (a) and matrix of  $(H_2O)_{100}$  icosahedra (lacy structure of water) (b)

$(H_2O)_{280}$  icosahedral clusters may also form strands – a super strand of eight water icosahedrons. Eight complete but overlapping icosahedral clusters form this strand-like structure containing water molecules. (Figure 1). These structures are far less strained than the more-symmetric supercluster structuring and are as expected in the related low-energy minimal polytetrahedral clusters (Dzugutov clusters) (Doye and Wales, 2001). Dzugutov clusters illustrate liquid water’s strong tendency for icosahedral and polytetrahedral order, where they are stabilized by the presence of high barriers between potential energy minimal structures, which is of particular importance at low temperatures. The presence of these clusters is in agreement with computer simulation studies. They may explain the properties of deeply-supercooled water, as it is in agreement with such water being a good solvent for inert gas (Xe) atoms, which fit well into the dodecahedral clathrate sites, but being a very poor solvent for salt (LiCl), which would have to disrupt the hydrogen-bonding. It would also possess the very low excess entropy and enthalpy of the found crystallization.

Nanometric water drops are the basis of the ‘magical’ and surprising structural architecture. These nanodroplets have much stronger interactions than normal water surface. The platform for a better understanding



of atmospheric, biological, geological, ecological, and life processes can be seen in a new light and through insights of the novel Supra natural nano phenomenon – the Jean Marie Lehn bonds (Figure 2).

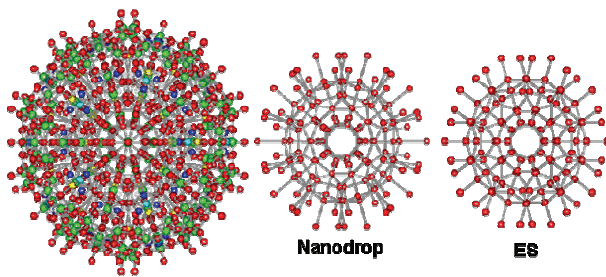


Figure 2. Nanometric water drops

The new occurrence is the complex network icosahedron structure of water with hollow spaces, which is able to trap toxic metal cations, other impurities and pollutants (Figure 3).

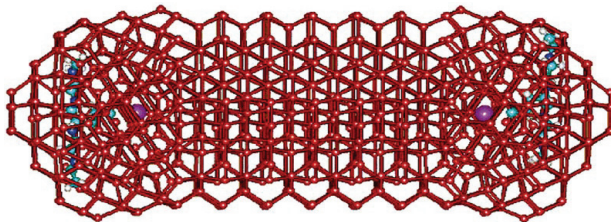


Figure 3. Trapped metal cations in the structural network of dynamic water clusters

## LIQUID WATER ANOMALIES

Currently, 75 anomalies of nano water cluster architecture are known and defined and they are a direct consequence of the highly complex and intriguing icosahedron structure of quant water molecules present in all bio cell types and all natural phenomena in the environment, water, air, soil, and biosphere, including the technosphere. Chaplin divided the anomalies into categories (classes and subclasses): water phase, density, material, thermodynamic and physical anomalies (Chaplin, 2008, 2019; Holten et al., 2014; Russo and Tanaka, 2014; Tanaka, 2022).

Figure 4 shows the simplified dynamic and vibrant network of water molecules with tetrahedral structure preference. The liquid water architecture and structure complexity presented in 2D (Figure 4) includes: (A) a monomer “free” water; (B) dimer of two molecules of OH bonded by H bonds; (C) hole (space in which intermolecular H bonds are broken); (D) trapped water molecule in a structured cage; (E) hole; (F) vacancy (space where intermolecular H bonds have not been formed); (G) random bound water; (H) ordered region of (H<sub>2</sub>O)<sub>6</sub>; (I) broken cluster “cage”; (J) chain of water molecules; and (K) hole.

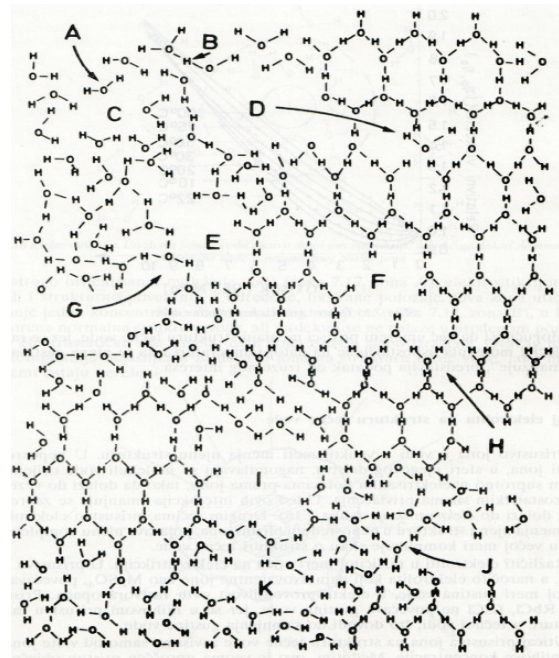


Figure 4. Simplified vibrant water clusters in 2D

The free energy of a nonideal mixture of two types of local structures (two states) can be written as

$$G = G_0 + s\Delta G + k_B T [s \ln s + (1-s) \ln(1-s)] + J s(1-s), \quad (1)$$

where  $\Delta G$  is the free-energy difference between LFTS (locally favoured tetrahedral structure) and DNLS (disordered normal-liquid structure),  $s$  is the fraction of LFTS,  $J$  is the strength of the cooperatives that are affected by temperature changes, and  $k_B$  is the Boltzmann constant.  $\Delta G$  can be further written as  $\Delta G = \Delta E - T\Delta\sigma + P\Delta V$ , where  $\Delta E$ ,  $\Delta\sigma$  and  $\Delta V$  characterize the energy, entropy and volume differences between LFTS and DNLS, respectively.

### Thermodynamic anomalies

The category of thermodynamics distinguishes specific anomalies that are affected by temperature changes.

The heat of fusion of water with temperature exhibits a maximum at -17 °C, having over twice the specific heat capacity of ice or steam, and the specific heat capacity (CP) is unusually high (minimum of 36 °C and maximum of about -45 °C). Usually, the CP has the minimum in connection to pressure, the high entropy of vaporization, and the high heat of sublimation. The most important is the thermal conductivity of water, which is high and increases to the maximum at about 130°C and it is associated with types of substances (inorganic, ionic, non-ionic and organic) dissolved or present in water.

In this model, slow and fast water molecules contribute differently to the total activation energy and thus the T, P dependence of a dynamic quantity X (e.g. the viscosity  $\eta$ , the inverse of diffusion coefficient  $1/D$ , and the rotational relaxation time  $\tau_R$ ) is given by the following generalized Arrhenius law:

$$X = X_0 \left(\frac{T}{T_r}\right)^\lambda \exp\left[\frac{E_s - P\Delta V_a}{R_g T}\right], \quad (2)$$

where  $E_s$  and  $E_{ap}$  are the activation energy contributions from slow and fast water molecules, respectively, and  $\Delta E_a = E_{as} - E_{ap}$ . At high temperatures, where the liquid structure is predominantly DNLS, water's dynamics weakly slow down upon pressurization, which is expressed by the following pressure-dependent activation energy:  $E_{ap} = E_{a0} + P\Delta V_a$ .  $\lambda$  is a physical exponent ensuring that the Stokes–Einstein relations,  $D\tau_R = \text{constant}$  and  $D\eta/T = \text{constant}$ , hold at high temperatures (49, 72). Experimental data suggest  $\lambda = 1$  for  $\eta$  and 0 for  $1/D$  and  $\tau_R$  for the experimentally measured O–O correlations, respectively (Shi and Tanaka, 2020).

### Physical anomalies

Water has an unusually high viscosity, which increases together with the Prandtl number as the temperature is lowered, and decreases with the pressure below 33 °C. Large diffusion decreases as the temperature is lowered. The thermal diffusivity rises to a maximum at about 0.8 GPa. Another unique and astounding characteristic of water is its unusually high surface tension (the Jones-Ray effect applies) (Figure 2). Some salts prevent the coalescence of tiny bubbles and the molar ionic volumes of salts show maxima with respect to temperature.

### Phase anomalies

In phase anomalies, the unusually high melting, boiling and critical points are the most intriguing. Solid water exists in a wider variety of stable (and metastable) crystal and amorphous structures than other materials. Hot water may freeze faster than cold water (the Mpemba effect) and vibrates longer (Burrige and Hallstadius, 2020). Water molecules shrink as the temperature rises and expand as the pressure increases.

### Water density anomalies

The density of ice increases on heating (up to 70 K), while pressure reduces ice melting point. The water shrinks during melting. The surface of the water is denser than the bulk, and pressure reduces the temperature of maximum density. There is a density minimum in supercooled water. Water has a low coefficient of expansion (thermal expansivity). During the melting and heat increase, water clusters are moving closer to each other. Water has unusually low compressibility. The speed of sound increases with temperature up to 74 °C and can show a minimum. ‘Fast sound’ is found at high frequencies and shows a discontinuity at higher pressure. The volume changes as liquid changes to gas.

### Water material anomalies

No aqueous solution is ideal.  $D_2O$  and  $T_2O$  differ significantly from  $H_2O$  in their physical properties and their phase and quantum behaviour. The mean kinetic

energy of water's hydrogen atoms increases at low temperatures. The solubility of nonpolar gases in water decreases with temperature to a minimum and then rises. The relative permittivity shows a temperature maximum. Proton and hydroxide ion mobilities are anomalously fast in an electric field. The electrical conductivity of water rises to a maximum at about 230 °C. The electrical conductivity of water rises considerably with frequency. Acidity constants of weak acids show temperature minima. Under high pressure, water molecules move further away from each other with increasing pressure, which is a density-distance paradox.

## THE KEY CONCLUSIONS AND DISSEMINATION OF THE IPA PROJECT

The results of performed analyses and measurements show that the eco-status of Lake Zornatica and Tompojevački ritovi wetland varies from moderate to poor, making it exceptionally important to emphasize the need for the protection and preservation of these sensitive water systems. Uncontrolled discharges from settlements, agricultural areas, and activities pose a significant threat to the water and the environment. There are many good practice examples in countries such as Serbia and Croatia, as well as Europe, that demonstrate that protecting the most sensitive waterways and semi-closed aquatic systems can only be accomplished through a process of awareness and implementation of the most viable solution.

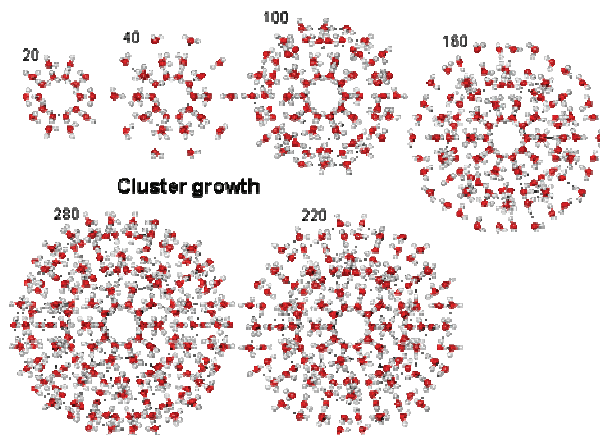
The data and work from Project SeNS Wetlands yielded 12 conference papers and 4 original journal papers:

1. Sremački, M., Obrovski, Petrović, M., Mihajlović, I., Dragičević, P., Radić, J. and Vojinović Miloradov, M. (2020). Comprehensive environmental monitoring and assessment of protected wetland and lake water quality in Croatia and Serbia;
2. Vojinović Miloradov, M., Mihajlović, I., Sremački, M., Petrović, M., Obrovski, B., Sabadoš, K., Kicošev, V., Dragičević, P. and Radić, J. (2020). Portrait of the INTERREG IPA Project between Croatia and Serbia, SeNS WETLANDS;
3. Obrovski, B., Mihajlović, I., Vojinović Miloradov, M., Sremački, M., Španik, I. and Petrović, M. (2022). Groundwater quality assessment of protected aquatic eco-systems in cross-border areas of Serbia and Croatia;
4. Sremački, M., Obrovski, B., Mihajlović, I., Petrović, M., Vojinović Miloradov, M., Kisošev, V., Dragičević, P. and Radić, J. (2018). Surface water quality of protected aquatic systems in Serbia and Croatia.



## FINAL REMARKS ON THE LIQUID WATER MISTIC ICOSAHEDRON ARCHITECTURE

Water is an anomalous liquid with specific, intriguing, and unique phenomenological behaviour, and its physicochemical properties are quite different from the majority of fluids. The typical structural anomaly has the non-monotonic behaviour of structural order parameters of the aquatic system as a function of the temperature and pressure. Figure 5 illustrates the growth of the water cluster from 20 to 280.



**Figure 5.** Water cluster formation and growth

The most recent data show that water has more than 70 anomalous characteristics, such as density, temperature, polarity, thermodynamic, dynamic and structural anomalies, polymorphism, and many more.

Despite its simple-looking HOH assembly, water is one of the most complex icosahedron architectural structures as a consequence of water cluster association formed by numerous intermolecular electrostatic Jean Marie Lehn H bonds. A significant aspect in the forming process of water cluster sets is the dependence on the temperature (thermodynamic, dynamic and kinetic anomaly processes), the pressure, the concentration, and especially the presence of electrolytes due to high polarity (dipole moment  $D_m=6.14 \cdot 10^{-30} \text{Cm}$ ) of water and other substances dissolved in water, as well as different important thermodynamic factors. The primary postulate for water abnormality is that different temperature intervals correspond to the aquatic intermolecular form's disposition. Since ice is less dense than water, it floats forming an insulating layer that slows thermal conductivity from warmer water below to the air above. As the result, life in relatively large freshwater bodies (lakes, rivers) is protected from the harsh winter weather above and keeps it liveable (occurrence of lake stratification). The high heat capacity of the water bodies (oceans and seas) allows them to act as heat reservoirs and to moderate our climate change. The compressibility of water reduces the sea level by about 40m, freeing up more usable land. Water's high surface tension and its expansion upon freezing supports and

enhances erosion. Water has a high hydration potential (Halle and Davidovic, 2003). In the human body, the process of aquation necessarily aquatizes biological macromolecules, proteins and nucleoid acids that determine their 3D structure and function in solution substances<sub>(aq)</sub>.

Vibrant transformation from one structure to another is perpetual and constant. The building of tetrahedral H bonds in an aquatic environment as cooperative phenomena unstoppably repeats the creation and degradation of flickering clusters. Even though the flickering water molecule clusters have a short half-life,  $10^{-10}$  up to  $10^{-11}$  seconds, it is long enough to shape and organize a structure of high bio significance for liquid water form, biological fluids, and life in total. The life of biosystems and non-biosystems depends on these anomalous characteristics of water.

Water's structural architecture  $(\text{HOH})_n$  remains an unsolved research task.

With the application of the technologies based on the AI and comprehension of the new relations and bonds that shape quantum mechanics laws, it can be expected that new anomalies will emerge.

## REFERENCES

- Burridge, H. C. and Hallstadius, O. (2020) 'Observing the Mpemba effect with minimal bias and the value of the Mpemba effect to scientific outreach and engagement', *Proceedings of the Royal Society A: Mathematical, Physical and Engineering Sciences*, 476(2241), p. 20190829. doi: 10.1098/rspa.2019.0829.
- Chaplin, M. (2008) *Explanation of the Physical Anomalies of Water*. London South Bank University.
- Chaplin, M. F. (2019) 'Structure and Properties of Water in its Various States', in *Encyclopedia of Water*. Wiley, pp. 1–19. doi: 10.1002/9781119300762.wsts0002.
- Debenedetti, P. G., Sciortino, F. and Zerze, G. H. (2020) 'Second critical point in two realistic models of water', *Science*, 369(6501), pp. 289–292. doi: 10.1126/science.abb9796.
- Doye, J. P. K. and Wales, D. J. (2001) 'Polytetrahedral Clusters', *Physical Review Letters*, 86(25), pp. 5719–5722. doi: 10.1103/PhysRevLett.86.5719.
- Halle, B. and Davidovic, M. (2003) 'Biomolecular hydration: From water dynamics to hydrodynamics', *Proceedings of the National Academy of Sciences*, 100(21), pp. 12135–12140. doi: 10.1073/pnas.2033320100.
- Holten, V. *et al.* (2014) 'Two-state thermodynamics of the ST2 model for supercooled water', *The Journal of Chemical Physics*, 140(10), p. 104502. doi: 10.1063/1.4867287.
- Palmer, J. C. *et al.* (2018) 'Advances in Computational Studies of the Liquid–Liquid Transition in Water and Water-Like Models', *Chemical Reviews*, 118(18), pp. 9129–9151. doi: 10.1021/acs.chemrev.8b00228.
- Russo, J. and Tanaka, H. (2014) 'Understanding water's anomalies with locally favoured structures', *Nature Communications*, 5(1), p. 3556. doi: 10.1038/ncomms4556.

Shi, R. and Tanaka, H. (2020) 'The anomalies and criticality of liquid water', *Proceedings of the National Academy of Sciences*, 117(43), pp. 26591–26599. doi: 10.1073/pnas.2008426117.

Tanaka, H. (2022) 'Roles of liquid structural ordering in glass transition, crystallization, and water's anomalies', *Journal of Non-Crystalline Solids: X*, 13, p. 100076. doi: 10.1016/j.nocx.2021.100076.

Tao, Y. *et al.* (2017) 'Different Ways of Hydrogen Bonding in Water - Why Does Warm Water Freeze Faster than Cold Water?', *Journal of Chemical Theory and Computation*, 13(1), pp. 55–76. doi: 10.1021/acs.jctc.6b00735.

## ACKNOWLEDGEMENTS

The work presented in this paper is financially supported by the IPA Project "Active Sensor monitoring network and environmental evaluation for protection and wise use of WETLANDS and other surface waters – SeNs Wetlands", grant agreement no. [2017HR-RS135] of the Interreg IPA Cross-border Cooperation Programme Croatia-Serbia 2014-2020. The authors would like to give special thanks to project leaders from Serbia and Croatia.

## BIOGRAPHY of the first author

**Prof. Emeritus Mirjana Vojinović Miloradov, Ph.D.** is a long-time full professor with experience in the educational and research field of inorganic, bioorganic and environmental chemistry, with the key course *Physicochemical Principles in Environmental Engineering* in bachelor, master and doctoral studies.

Her scientific research activities are focused on the negative impact of contamination by highly hazardous, toxic and emerging substances on the quality of water, atmosphere, and human material, and the negative consequences of climate change. She has been a reviewer for 4 prestige peer-reviewed scientific journals in the continuum over an extensive period of time. As a guest lecturer, prof. Vojinović Miloradov taught at the University of Manitoba, Winnipeg, Canada, the University of Wageningen, Netherlands, the University of the United Nations, Bonn, Germany, Brno University of Technology and other Universities.

She held plenary lectures at numerous international and national conferences in Boston, Prague, Barcelona, Bratislava, Szeged, South Korea, Johannesburg, as well as Belgrade, Niš, Vršac, Kruševac, Subotica, Zlatibor, Novi Sad, Bor, Kragujevac and other Serbian cities. Professor Miloradov was a mentor for more than 40 MSc and 40 Ph.D. theses. She was the director of the Centre for Interdisciplinary Studies for Environmental Engineering at the University of Novi Sad for 10 years, the director of the Institute of chemistry at the Faculty of Natural Sciences, Novi Sad for 6 years, as well as the head of the Medical Chemistry chair at the Faculty of Medicine and the head of the Environmental Engineering chair at the Faculty of Technical Sciences. The professor was a coordinator and leader of more than 15 international projects (FP5, Tempus, Erasmus, NATO, IPA and bilateral) and numerous national projects. She is a member of the jury of the international Tesla festival of innovation, knowledge and creations. Professor Miloradov worked and taught at the University of Novi Sad on the Faculty of Technology, Faculty of Natural Sciences, Medical Faculty, Faculty of Philosophy (part time) and currently at Faculty of Technical Sciences.



MIRKO MARKIČ<sup>1</sup>

<sup>1</sup>University of Primorska,  
Faculty of Management

mirko.markic@guest.arnes.si

## MODERN CONCEPTS OF SAFETY MANAGEMENT SYSTEMS

**Abstract:** *To manage occupational safety and health, a multitude of tools, techniques and methods have been developed to help key stakeholders manage it successfully. In a company or other institution, various measures that can be used to manage occupational safety and health are available. The most frequently used measures are technical-technological, medical, educational, social, legal, economic, humanistic, and other. The focus of efforts in the management of occupational safety and health has changed significantly over the past three decades, shifting from a technical-technological point of view to organizational and behavioural sciences. Modern concepts of occupational safety system management are an emerging topic in theory, research, and practice. The purpose of this paper is to highlight the historical, substantive, and conceptual development of occupational safety management system models and the possible future directions.*

**Key words:** *management, systems, occupational safety, organization.*

## INTRODUCTION

Since 1970, organization-related factors (e.g. management support, management's commitment to safety, workplace safety status) have been considered as important causative agents in the occurrence of occupational accidents (Khanzode et al., 2012). The research of occupational safety management (OSM) is one of the major professional recommendations in theory as well as in everyday practice (Yorio et al., 2015). The activities in OSM should be based on the reliable and satisfactory safety-related information (Bing et al., 2017) and on surveillance by control loops (of human, technological, organizational and information systems) in order to ensure continuous safety of the operating systems (Wahlström and Rollenhagen, 2014). Mandatory and voluntary management attention was focused on the development and implementation of new safety management systems and on further activities suggested by these systems (Almklov et al., 2014). The ultimate commitment and vision of the OSM should be to achieve the highest levels of safety, i.e. the zero accident vision (Zwetsloot et al., 2013).

The field of OSM has been extensively investigated in theory and in practice in the last thirty years. And yet, there is no prevailing evidence either in favour or against the impact of OSM planning and/or implementation (Robson et al., 2007). Podgórski (2015) stated that despite the fact that OSM was being globally implemented and maintained in numerous enterprises for more than 20 years, there was no sufficient evidence that these systems were effective in terms of preventing and/or reducing the number of work-related injuries and diseases. On the other hand, Buhai, Cottini and Westergård-Nielsen (2013)

highlighted the absence of empirical studies that would link the quality of working conditions with economic performance, while Fernandez-Muniz and his team (2009) proposed that researchers should study more extensively the impact of the OSM system on the competitiveness of an enterprise.

Occupational safety and health has a significant impact on human integrity, costs (of an individual, enterprise and/or government) and the productivity and competitiveness of enterprises and other institutions. Consequently, exploring the importance of OSM is a core activity of this type of research worldwide, both in theory and in everyday practice.

## OCCUPATIONAL SAFETY MANAGEMENT

### The concept of management tasks

Some of the most distinguished theoreticians and practitioners in this field (Fayol, 1949; Bernard, 2001; Daft, 2010) based their research on the recognition of the following management tasks: *planning, organizing, leading and controlling*. Considering this perspective, the OSM was defined as a four-dimensional concept whereby all OSM related processes have been assigned to one of the selected management tasks (Pavlič et al., 2021).

*Planning.* Managers have the authority and responsibility for planning, organizing, implementing, and controlling the occupational safety and health (OSH) policy (Takala, 2003). Managers have to design an effective OSM program and strive for its successful implementation in all areas (Akpan, 2011). A government-implemented intervention in the field of

OSM is positive; the effect is also associated with safer and healthier behaviour (Denny, 2012).

*Organizing.* Legal obligation has the biggest impact on the incidence of work-related injuries, requiring the establishment of a committee for OSH in an enterprise (Smitha et al., 2001). The practice of organizing and implementing OSH represents an aspect of general management, which defines and implements the occupational safety and health policy (Harms-Ringdahl, 2004). Cheng and co-workers (2012) have found that there is a significant positive correlation between the existence of OSH committees and OSH performance. The inclusion of OSH committees into the OSM system is of paramount importance for the quality of working conditions (Morse et al., 2013).

*Leadership.* Leaders must provide adequate working conditions that ensure safe work (Arzenšek and Musek Lešnik, 2016). Caravellova (2011) defines leadership as a key factor for the safety outcomes. Chinda (2012) considers the management as a key driver for effective implementation of OSH; he states that strong commitment of a leader is crucial in OSH promotion. The key factors influencing OSH are leadership, management, and systemic thinking at all levels of an organization, as well as the appropriate attitude towards OSH from all employees (Takala et al., 2014). It is considered that successful OSM creates "a positive safety culture and atmosphere" (Zohar, 2010).

*Controlling.* Controlling activities should be focused both on preventing and identifying hazardous conditions and circumstances (Heinrich et al., 1980). Petersen (1988) argues that the most successful managers take responsibility for designing and implementing a specific system that would effectively control the risks associated with the functioning of an organization. Demichela, Piccinini and Romano (2004) concluded that OSM is often formulated without pre-defined control and/or quantitative risk assessment. In order to identify and improve the quality of OSH, an evaluation of working conditions is recommended (Chinda, 2012).

### **The concepts of leadership and occupational safety**

In the past few decades organizations all over the world have been searching for the elements that constitute continuous organizational success in all fields of its activity (De Wall, 2021). Safe and healthy working environment, as an essential element of work quality and therefore organizational success, represents one of the most important advanced fields in organizations (Lingard and Yesilyurt, 2003). However, it is leadership that is the crucial success element for the use of quality health and safety system in organizations (Collins and Porras, 2000). The importance of leadership for effective OSM has been the focus of research in industry for a number of years, especially in the energy and manufacturing sectors (Flin and Yule, 2004). Senior management's commitment is crucial to a positive OSH culture (Guldenmund, 2000). Similar

findings have been highlighted in other investigations across a range of industries (Donald and Canter, 1994). Zohar (2002) established that the safety climate mediated the leadership-injury relationship in work groups. All these results indicate that the leadership commitment to OSH is recognized as a fundamental component of an organization's safety culture (Reason, 1998) and safety performance (Hofman et al., 1995). Occupational health and safety-oriented leadership has become not merely a fashionable trend, but a necessary and integral part of the strategic planning for the sustained development and success of the organization. Leadership is defined as the activity of top executives who display high levels of persistence, overcome significant obstacles, attract dedicated people, influence groups of people towards the achievement of goals, and play key roles in guiding their companies through crucial episodes in their history (Collins and Porras, 2000). Leadership is the ability to influence people to attain goals. According to (Daft, 2010), leadership is reciprocal, as leaders are involved with other people in the achievement of goals. Leadership is the lifting of man's vision to higher sights, the raising of a man's performance to a higher standard, and the building of a man's personality beyond its normal limitations (Drucker, 1993). Comparing leaders with managers, it can be argued that managers do things right while leaders do the right things. The clear implication is that 'managing' is not only different from, but maybe even the opposite of 'leading'; moreover, it is more useful to 'lead' than to 'manage' (Pascale, 1991).

OSH is a cross-disciplinary area concerned with protecting the safety, health and welfare of people engaged in work or employment (Wilcock, 2006). Awareness of OSH grew in the early years of the 20<sup>th</sup> century, along with larger concerns about the wages and living conditions of workers (Tetrick and Quick, 2003). The main focus in OHS is on three different objectives: (1) the maintenance and promotion of workers' health and working capacity; (2) the improvement of the working environment and work to become conducive to OSH; and (3) development of work organizations and working cultures in a direction that supports OSH and in doing so also promotes a positive social climate and smooth operation, while potentially enhancing productivity of the undertakings (Backer et al., 1996). There are numerous problems with the approach to developing a valid measure (indicators) of OHS (Cooper, 2008). What is needed to enhance safety in the long term is a measurement approach that focuses on the proximal causes of safety incidents. For instance, measuring management practices that increase employees' levels of trust in management and perceived safety climate would be beneficial to the extent that these factors predict subsequent safety performance (Zacharatos et al., 2005). However, organizations need to be aware of what hazards or stressors may be present in the workplace of the future and to take preventive measures not only to protect employee well-being but

also to protect themselves against any potential legal action from injured employees (Sparks et al., 2001). Dangerous and hazardous factors in general can be classified into six categories (Qiang and Chow, 2007) according to the direct cause of the incident and occupational hazard: *physical factors, chemical factors, biological factors, psychological and physiological factors, behavioural factors, and other dangerous and hazardous factors*. Piňosová and Králiková (2021) classified risk factors into seven categories / division of the working environment: *biological factors, chemical factors, ergonomics, occupational safety factors, workspace, physical factors, and socio-psychological factors*.

Focusing on risks for OSH is the key to preventing disease and injury. The most emotive and tangible images concerning health are those of people suffering from a disease. However, preventing disease and injury requires a systematic assessment and elimination of their causes.

### The leadership health and safety models

There are numerous business organization models for OSH leadership in the world (Markič et al., 2015). The largest differences among these models lie in the number of factors (elements) influencing the state of OSH. Hansen (2000) defined the Safety Excellence Model consisting of culture, elements of safety, organization, and an individual. According to Hidley (2004), safety excellence consists of seven elements: education, implementation, engineering, behaviour, organization, leadership, and culture. Geller and Boyce (2001) designed a model called People-Based Safety, which is based on the following elements: behaviour, work methods and motivation management, a positive and systemic approach to improvements, information collection, and communication. The Successful Health and Safety Model (by NSC, 2005) contains three groups/clusters of fundamental elements: governance and management (leadership and commitments, communication and documentation, assessment and reviews, and training and education), technical/operational elements (risk identification, assessment, supervision, engineering and operational safety and medical programs), and 'soft' elements – culture and behaviour (involving employees in decision-making in the field of health and safety, motivation, behaviour, practices, and employee education and training). Carrillo (1998) proposed the Three-Dimensional Model for occupational health and safety management containing three dimensions operating simultaneously: self-confidence, credibility and development of organizational competences. The model is based on five steps: insight, direction, focus, ability, and accountability. He established that lack of trust/confidence and credibility is the most common obstacle to enhancing safety culture. Another model – Leadership Diamond – the model designed by Koestenbaum (2002) is based on five basic dimensions

or relationship clusters relating to leadership activities: greatness, courage, vision, ethics, and reality.

Yuling and Guldenmund (2018, pp. 107-108) illustrate the role of barriers in the event models and the management structure to control their performance.

Considering the above-mentioned organizational models for OSH leadership and their dimensions or elements, it can be concluded that no model contains equivalent elements. In some models, the so called 'soft' factors (e.g. culture, organization, leadership, behaviour, motivation, communication, trust/confidence, credibility, courage, vision, ethics, cooperation, and responsibility) prevail, while in other models, the so called 'hard' factors (e.g. engineering, supervision, systems approach, technics, and technology) prevail.

### Occupational safety and health management systems

Occupational safety and health management (OSHM) systems have both a long and a short story. They can be traced back to early developments before the Second World War, such as the Safety-First movement (Heinrich, 1931), the rise of system thinking (in the 1980s), and the subsequent development of management systems in large firms such as DuPont (Hopkins, 2006). At the same time, OSHM history is fairly short. It was only in the 1990s that OSHM systems developed into models that found a more widespread use.

Two kinds of developments were vital in this respect:

– Regulatory developments as legislation started to require systematic management to control occupational hazards. The most prominent example is the EU framework directive from 1989 (Walters (Ed.), 2002), ILO Convention (e.g. Occupational Safety and Health Convention, 1981) (No. 155), and national state regulations. Although they do not explicitly require companies to have an OSHM system, their requirements can be regarded as comprising a range of system elements (planning, organizing, leading, and controlling) implicitly suggesting an OSHM system.

– Voluntary development of the OSHM system: standards and the associated process of certification (Zwetsloot, 2000). This resulted in ISO 9000:2015 Quality inspired standards, especially the ISO 14001:2015 Environmental management systems, ISO 45001:2018 Occupational health and safety management systems, ISO 31000:2018 Risk management, and ISO 26000:2010 Guidance on social responsibility. The International Labour Organization also published its OSHM System Guidelines in 2001 (ILO, 2001), and the European Agency for Safety and Health (EU-OSHA) issued the publication Management Leadership in Occupational Safety and Health – a practical guide (EU-OSHA, 2012).

Yuling and Guldenmund (2018) state that the generic OSHM systems consist of two main elements: the *risk*



control system and the learning system, each of which can be unpacked to reveal several sub-elements. The generic OSHM system is influenced through feedback by its own system performance and the societal context in which it operates.

The risk control system consists of the following sub-elements or management processes (Yuling and Guldenmund, 2018):

- The primary and subsidiary business processes describe the safety management system covering all life cycle phases (LCP), and as such it is responsible for the design, the construction and the technology of the organization and its output(s).
- The risk inventory and analysis in all LCPs and the transitions between them is concerned with identifying and examining the organization's hazards and understanding how these can become manifest and be controlled.
- The risk barriers and controls for all LCPs and transitions, plus requirements for their proper functioning, is concerned with the implementation of risk barriers and controls. It describes the management system within its particular context and its proper functioning.
- Finally, the management system to provide all requirements for proper functioning of technical and procedural barriers and controls contains the so-called delivery systems, which deliver the safety barriers and controls.

The learning system consists of the following sub-elements or management processes (Yuling and Guldenmund, 2018):

- Inspection and monitoring is the process that receives real time information from the actual risk controls and verifies it.
- The auditing and management review is concerned with the assessment of the safety management and their performance in order to enable continuous improvement.
- The incident and accident registration and analysis is the end and also the beginning in an SMS, as this process is aimed at identifying hazards and providing critical information for the management of safety in the organization.

An integrated management system is more advanced than independent safety systems, as safety is just one of the comprehensive organization management objectives (Yuling and Guldenmund, 2018, p. 118). The implementation of OSHM systems had its own dynamics and generated new issues. Having an OSHM system in place is increasingly becoming a business-to-business requirement, as is the ISO 9000 Quality management standard. Since the early 1990s, this development has also raised the issue of OSHM integration with quality and/or environmental management systems, and with business processes (Zwetsloot et al., 2013).

## CONCLUSION

This paper described occupational safety and health management (OSHM) systems in terms of the four core aspects: the concepts of management tasks, the concepts of leadership and occupational safety, the leadership health and safety models, and occupational safety and health management systems.

The concept of management tasks is based on the four main functions in the field of occupational safety and health: planning, organizing, leading, and controlling. *Planning* involves constructing and performing OSH policy, defining aims and goals, and determining a strategy for implementation. *Organizing* involves establishing a supportive safety structure (e.g. establishing an organizational unit and a committee for OSH). *Leading* involves providing adequate working conditions that ensure safe work (e.g. safety culture and safety climate, based on values and beliefs). *Controlling* should be focused on identifying and preventing hazardous conditions and circumstances (e.g. PDCA (Plan-Do-Check-Act) control process).

The concepts of leadership and occupational safety are based on an assumption that leadership represents the crucial success element for a quality OHS system in an organization. Top managers (e.g. directors, chiefs, executives) have the competence and responsibility for planning, organizing, implementing, and controlling the occupational safety and health policy.

The practical leadership health and safety models contain 'soft' (e.g. culture, organization, leadership, behaviour, motivation, communication, trust/confidence, credibility, courage, vision, ethics, cooperation, and responsibility) and 'hard' (e.g. engineering, supervision, systems approach, technics, and technology) factors.

The occupational safety and health management systems are possible in two ways – regulatory (legislation) and voluntary (standardization) development. The generic OSHM systems consist of two main elements: the risk control system and the learning system.

Future development of the OSHM is possible through its integration with quality, environment, risk, and social accountability standards, through consideration of sustainable development goals and aims, and in accordance with business processes in the organization.

## REFERENCES

- Akpan, E.I. (2011). Effective safety and health management policy for improved performance of organizations in Africa. *International Journal of Business and Management* 6 (3), pp. 159–165.
- Almklov, P.G., Rosness, R., Storkenson, K. (2014). When safety science meets the practitioners: Does safety science contribute to marginalization of practical knowledge. *Safety Science* 67 (August 2014), pp. 25-36.
- Arzenšek, A., Musek Lešnik, K., (2016). Human resources in a draught: how managers construed the role and meaning of human resource management during the 2008 economic crisis

- in Slovenia. *Economic Research – Ekonomska Istraživanja* 29 (1), pp. 101–117.
- Baker E, Israel BA, Schurman S. (1996). The Integrated Model: Implications for Worksite Health Promotion and Occupational Health and Safety Practice. *Health Education & Behavior* 23: pp. 175–190.
- Bernard, C.I. (2001). *The function of executive*. Cambridge (Mass.): Harvard University Press.
- Bing, W., Chao W., Bo, S., Lang, H., (2017). Evidence-based safety (EBS) management: A new approach to teaching the practice of safety management (SM). *Journal of Safety Research* 63 (1), pp. 21–28.
- Buhai, S.I., Cottini, E., Westergård-Nielsen, N. (2013). *The impact of work health and safety conditions on firm performance: Empirical evidence from Denmark*. Tinbergen Institute Discussion Paper, University of Aarhus, Aarhus School of Business, Department of Economics, pp. 08–13.
- Caravello, H. (2011). *The role of leadership in safety performance and results*. Doctoral Dissertation. Walden University. College of Management and Technology. <http://pqdtopen.proquest.com/doc/858376621.html?FMT=AI> (24. 5. 2019).
- Carrillo RAS. (1998). Expanding Managers Leadership Role. *Professional Safety Magazine* 43: pp. 38–41.
- Cheng, E., Ryan, N., Kelly, S. (2012). Exploring the perceived influence of safety management practices on project performance in the construction industry. *Safety Science* 50 (2), pp. 363–369.
- Chinda, T. (2012). A safety assessment approach using safety enablers and results. *International Journal of Occupational Safety and Ergonomics* 18 (3), pp. 343–361.
- Collins CJ, Porras JI. *Built to Last*. (2000). Successful Habits of Visionary Companies. 3rd ed. London: Random House.
- Cooper MD. (2008). Risk-Weighted Safety Culture Profiling. Proceedings of the 2008 SPE International Conference on Health, Safety & Environment in Oil & Gas Exploration and Production; 2008 Apr 15–17; Nice, France. New York: Curran Associates, Inc; 2008.
- Daft, R.L. (2010). *New era of management*. Mason: South-Western.
- De Waal AA. (2008). The secret of high performance organizations. Management Online Review [Internet]. 2008 Apr [cited 2021 Jan 10] [about 10 p.]. Available from: <http://www.moreexpertise.com>. 2021.
- Demichela, M., Piccinini, N., Romano, A. (2004). Risk analysis as a basis for safety management system. *Journal of Loss Prevention in the Process Industries* 17 (3), pp. 179–185.
- Denny, H.M. (2012). *Impact of occupational health interventions in Indonesia*. Doctoral dissertation. University of South Florida. <http://pqdtopen.proquest.com/doc/1283390488.html?FMT=AI> (6. 6. 2021).
- Donald I, Canter D. (1994). Employee attitudes and safety in the chemical industry. *Journal of Loss Prevention in the Process Industry* 7: pp. 203–208.
- Drucker PF. (1993). *The practice of management*. Oxford: Butterworth-Heinemann.
- Fayol, H., (1949). *General and industrial management*. London: Pitman.
- Fernández-Muñiz, B., Montes-Peón J.M., Vázquez-Ordás J. C. (2009). Relation between occupational safety management and firm performance. *Safety Science* 47 (7), pp. 980–991.
- Flin R, Yule S. (2004). Leadership for safety: industrial experience. *Quality and Safety Health Care* 13: pp. 45.
- Geller ES, Boyce TE. (2001). Applied Behavior Analysis and Occupational Safety. *Journal of Organizational Behavior Management* 21: pp. 31–60.
- Guldenmund FW. (2000). The nature of safety culture: a review of theory and research. *Safety Science* 34: pp. 215–257.
- Hansen LL. (2000). The architecture of safety excellence. *Professional Safety* 6: pp. 26–29.
- Harms-Ringdahl, L. (2004). Relationships between accident investigations, risk analysis and safety management. *Journal of Hazardous Materials* 111 (1), pp. 13–19.
- Heinrich, H.W. (1931). *Industrial Accident Prevention*, second ed. McGraw-Hill, New York.
- Heinrich, H.W., Petersen D., Roos, N., (1980). *Industrial accident prevention: A safety management approach*. New York: McGraw Hill.
- Hidley J. (2004). Creating outstanding safety leadership. Understanding and leveraging leadership's role in safety. Behaviour Science Technologies. Perspectives in Behavioural Performance Improvement, Jan/Feb: 8–12.
- Hofmann DA, Jacobs R, Landy F. (1995). High reliability process industries: Individual, micro, and macro organizational influences on safety performance. *Journal of safety Research* 26: pp. 131–148.
- Hopkins, A., (2006). What are we to make of safe behaviour programs? *Safety Science* 44, pp. 583–597.
- Khazode, V.V., Maiti J., Ray, P.K. (2012). Occupational injury and accident research: A comprehensive review. *Safety Science* 50 (5), pp. 1355–1367.
- Koestenbaum P. (2002). Leadership: the inner side of greatness: a philosophy for leaders. San Francisco: Jossey Bass.
- Lingard H, Yesilyurt Z. (2003). The effect of attitudes on the occupational safety actions of Australian construction workers: The results of a field study. *Journal of Construction Research* 4: pp. 59–69.
- Markič, M., Kolenc, I., Nikolić, V., Markič Hrast, S., Meško, M. (2015). Impact of top managers' leadership on occupational health and safety. *Technics technologies education management* 10 (2), pp. 268–280.
- Morse, T., Bracker, A., Warren, N., Goyzueta J., Cook M., (2013). Characteristics of effective health and safety committees: Survey results. *American Journal of Industrial Medicine* 56 (2), pp. 163–179.
- NSC (National Safety Council) [Internet]. [cited 2011 Sept 11]. Available from: [http://shop.nsc.org/Nine-Elements-of-a-Successful-Safety-and-Health\\_System-P1731.aspx](http://shop.nsc.org/Nine-Elements-of-a-Successful-Safety-and-Health_System-P1731.aspx). c2005.



- Pascale RT. *Managing on the Edge*. London: Penguin books; 1991.
- Pavlič, M., Živković, S. and Pavlič, A. (2021). Occupational safety management, working conditions, and economic performance. In: Živković, S.B. (ed.), Krstić, B. (ed.), Rađenović, T. (ed.). *Handbook of research on key dimensions of occupational safety and health protection management*, (Advances in human resources management and organizational development book series). Hershey, PA: Business Science Reference, 2021, pp. str. 27-46.
- Petersen, D. (1988). *Safety management*. New York: Aloray.
- Pišosová, M. and Králiková, R. (2021). Quality of the working environment: an overview of the current situation in the Slovak Republic. *Sigurnost*, 63 (4): pp. 373-389.
- Podgórski, D. (2015). Measuring operational performance of OSH management system – A demonstration of AHP – based selection of leading key performance indicators. *Safety Science* 73 (March 2015), pp. 146-166.
- Qiang C, Chow WK. (2007). A Discussion of Occupational Health and Safety Management for the Catering Industry in China. *International Journal of Occupational Safety and Ergonomics*; 13: pp. 333–339.
- Reason J. (1998). Achieving a safety culture: Theory and practice. *Work & Stress* 12: pp. 293–306.
- Robson, L.S., Clarke, J.A., Cullen, K., Bielecky, A., Severin, C., Bigelow, P.L., Irvin, E., Culyer, A., Mahood, Q. (2007). The effectiveness of occupational health and safety management systems interventions: a systematic review. *Safety Science* 45 (3), pp. 329–353.
- Smitha, M.W., Kirk, K.A., Oestestad, K.R., Brown, K.C., Seung-Dong, L. (2001). Effect of state workplace safety laws on occupational injury rates. *Journal of Occupational & Environmental Medicine* 43 (12), pp. 1001–1010.
- Sparks K, Faragher B, Cooper CL. (2001). Well-being and occupational health in the 21st century workplace. *Journal of Occupational and Organizational Psychology*, 74: pp. 489–509.
- Takala, J. (2003). *A safety culture that can save lives*. Geneva: International Labour Office.
- Takala, J., Hämäläinen, P., Saarela, K.L., Yun, L.Y., Manickam, K., Jin T.W., Heng, P., Tjong C., Kheng, L.G., Lim, S., Lin, G.S. (2014). Global estimates of the burden of injury and illness at work in 2012. *Journal of Occupational and Environmental Hygiene* 11 (5), pp. 326–337.
- Tetrick LE, Quick JC. (2003). Prevention at work: Public health in occupational settings. In: Quick, JC, Tetrick LE, editors. *Handbook of occupational health psychology*. Washington, DC: American Psychological Association; pp. 3–17.
- Wahlström, B., Rollenhagen, C., (2014). Safety management – A multi-level control problem. *Safety science* 69 (November 2014), pp. 3-17.
- Walters, D. (Ed.). (2002). *Regulating Health and Safety Management in the European Union*. P.IE.-Peter Lang, Brussels.
- Wilcock AA. (2006). *An occupational perspective of health*. 2nd ed. Thorofare: SLACK Incorporated.
- Yorio, P.L., Willmer, D.R., Moore, S.M. (2015). Health and safety management systems through a multilevel and strategic management perspective: Theoretical and empirical considerations. *Safety Science* 72 (February 2015), pp. 221–228.
- Yuling, L. and Guldenmund, F.W. (2018). Safety management systems: A broad overview of the literature. *Safety Science* 103, pp. 94-123.
- Zacharatos A, Barling J, Roderick DI. (2005). High-Performance Work Systems and Occupational Safety. *Journal of Applied Psychology* 90: pp. 77–93.
- Zohar D. (2002). The effects of leadership dimensions, safety climate, and assigned priorities on minor injuries in work groups. *Journal of Organizational Behavior* 23 (1), pp. 75–92.
- Zohar, D. (2010). Thirty years of safety climate research: Reflections and future directions. *Accident Analysis & Prevention* 42 (5), pp. 1517-1522.
- Zwetsloot, G.I.J.M. (2000). Developments and debates on OHSM system standardisation and certification. In: Frick, K., Quinlan, M., Langaa Jensen, P., Wilthagen, T. (Eds.), *Systematic Occupational Safety & Health Management: Perspectives on an International Development*, Pergamon-Elsevier Science. pp. 391-412,
- Zwetsloot, G.I.J.M., Aaltonen, M., Wybo, J.L., Saari, J., Kines, P., De Beeck, R.O. (2013). The case for research into the zero accident vision. *Safety Science* 58 (October 2013), pp. 41–48.

## ACKNOWLEDGEMENTS

The author acknowledges the financial support from the Slovenian Research Agency (research core funding No. P5-0049).

## BIOGRAPHY of the author

**Mirko Markič** obtained his PhD in the field of Organizational Science at the University of Maribor. After 12 years of activity as a safety engineer in the automotive industry, he was employed at the Faculty of Management, University of Primorska.



He is a professor teaching Management and leader/member of 17 research projects and economic projects. His bibliography comprises more than 680 publications in the field of management and public health (occupational safety).

SASA KENJEREŠ<sup>1,2</sup>

<sup>1</sup>Delft University of Technology,  
Faculty of Applied Sciences,  
Chemical Engineering Department,  
Delft, The Netherlands

<sup>2</sup>J.M. Burgerscentrum, Research  
School for Fluid Mechanics, Delft,  
The Netherlands

<sup>1</sup>s.kenjeres@tudelft.nl

## COMPUTATIONAL FLUID DYNAMICS AND ATMOSPHERIC CHEMISTRY FOR PREDICTIONS OF A CITY POLLUTION

**Abstract:** *This work presents an application of an integrated computational fluid dynamics and atmospheric chemistry method in simulating flows and turbulent dispersion in complex urban areas. The developed method was applied to a characteristic traffic emission in the city of Rotterdam, The Netherlands. The simulation domain included a neighborhood domain of approximately 2x2 km<sup>2</sup> with the inclusion of 1800 building blocks, resulting in a numerical mesh of 5.4x10<sup>6</sup> control volumes, which enables a spatial resolution of 1-2 m at the street scale. The atmospheric turbulent airflow was simulated by a two-equation (k - ε) eddy-viscosity-based turbulence model with a characteristic time-scale limiter. The atmospheric chemistry was simulated by the generic reaction set (GRS) model, which provides detailed information on the resulting NO-NO<sub>2</sub>-O<sub>3</sub>-RP-ROC-S(N)GN distributions. The method proved to be numerically robust and computationally efficient and is recommended for future investigations of turbulent dispersion of chemically reactive species in real-city domains.*

**Key words:** computational fluid dynamics (CFD), atmospheric chemistry, generic reaction set (GRS), turbulent dispersion, city pollution;

### INTRODUCTION

At present, urban pollution remains one of the key problems in the development of rapidly growing cities around the world. Increased levels of local pollution within the urban areas are often triggered by a sudden release of industrial and/or traffic emissions coupled with a negative impact of the meteorological conditions (e.g. change of wind direction, an appearance of the stable thermal stratification, etc.). To find the optimal solution and to mitigate such possible case scenarios, computer simulation-based techniques based on solid physics and atmospheric chemistry foundations can play an important role in improving the current situations as well as in future city planning and developments.

Here we are presenting the results of a recently developed numerical simulations approach that can be applied to predict local levels of the industrial and/or traffic emission in complex urban areas. The numerical model integrates computational fluid dynamics (CFD) and atmospheric chemistry. The former is providing the local velocity, pressure, and concentration of various species, as well as the turbulence parameters (e.g. turbulent kinetic energy and its dissipation rates). The latter includes complex generic reaction sets for describing the chemical interactions between various reactive species (e.g. NO, NO<sub>2</sub>, O<sub>3</sub>, etc.).

### GOVERNING EQUATIONS

The phenomena of the turbulent dispersion of reactive pollutants within complex urban areas can be described by a set of the PDEs representing conservation of mass, momentum, and species. Within the transient Reynolds-Averaged Navier-Stokes (T-RANS) approach in modeling highly turbulent flow regimes, additional transport equations need to be introduced to provide the second moments of the velocity field and reactive species. A concise overview of the generic transport equations, which form the backbone of our numerical simulation approach is provided next, Kenjeres and Hanjalic (2009), Kenjeres et al. (2015):

$$\frac{\partial U_i}{\partial t} + U_j \frac{\partial U_i}{\partial x_j} = \frac{\partial}{\partial x_j} \left[ \nu \left( \frac{\partial U_i}{\partial x_j} + \frac{\partial U_j}{\partial x_i} \right) - p \delta_{ij} - \overline{u_i u_j} \right] \quad (1)$$

$$\frac{\partial C^{(k)}}{\partial t} + U_j \frac{\partial C^{(k)}}{\partial x_j} = \frac{\partial}{\partial x_j} \left[ \mathcal{D}_c \frac{\partial C^{(k)}}{\partial x_j} - \overline{c^{(k)} u_j} \right] \pm R_c^{(k)} \quad (2)$$

where  $U_i$  is the velocity,  $p$  is the pressure,  $\overline{u_i u_j}$  is the turbulent stress tensor,  $\overline{C^{(k)}}$  is the concentration of the species ( $k$ ),  $\overline{c^{(k)} u_j}$  is turbulent concentration flux, and

$R_c^{(k)}$  is the chemical reaction rate. The turbulent stress tensor and turbulent mass flux of reactive species are obtained by applying the eddy-viscosity model (EVM)

and generalized gradient diffusion hypothesis (GGDH) approaches, which can be written as:

$$\overline{u_i u_j} = \frac{2}{3} k \delta_{ij} - \nu_t \left( \frac{\partial U_i}{\partial x_j} + \frac{\partial U_j}{\partial x_i} \right) \quad (3)$$

$$\overline{c^{(k)} u_i} = -C_\phi \overline{u_i u_j} \frac{\partial C^{(k)}}{\partial x_j} \quad (4)$$

To get a closed system of governing equations, additional transport equations of the turbulent kinetic energy and its dissipation rate are introduced:

$$\frac{\partial k}{\partial t} + U_j \frac{\partial k}{\partial x_j} = \frac{\partial}{\partial x_j} \left[ \left( \nu + \frac{\nu_t}{\sigma_k} \right) \frac{\partial k}{\partial x_j} \right] + P_k - \varepsilon \quad (5)$$

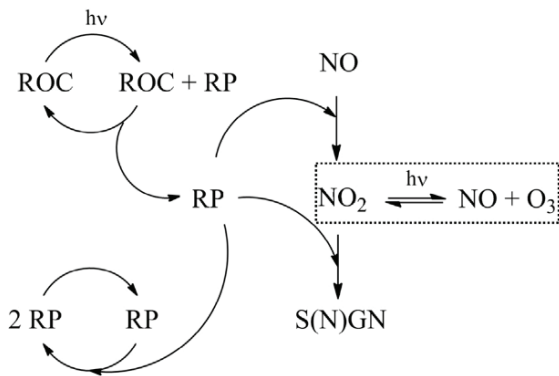
$$\frac{\partial \varepsilon}{\partial t} + U_j \frac{\partial \varepsilon}{\partial x_j} = \frac{\partial}{\partial x_j} \left[ \left( \nu + \frac{\nu_t}{\sigma_\varepsilon} \right) \frac{\partial \varepsilon}{\partial x_j} \right] + \frac{1}{T} (C_{\varepsilon 1} P_k - C_{\varepsilon 2} \varepsilon) \quad (6)$$

where

$$\nu_t = C_\mu k T, \quad T = \min \left( \frac{k}{\varepsilon}, \frac{0.6}{\sqrt{6} C_\mu |S|} \right) \quad (7)$$

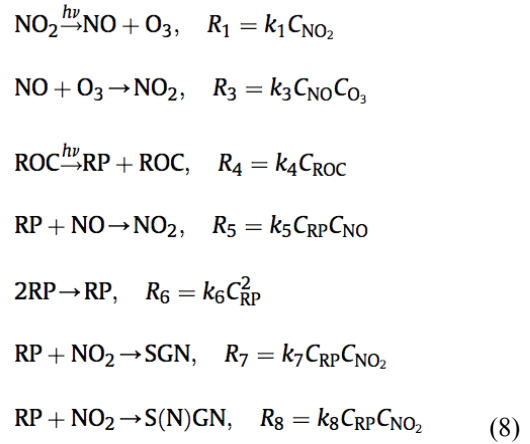
are the turbulent viscosity ( $\nu_t$ ), characteristic time scale ( $T$ ), ( $P_k$ ) production of the turbulent kinetic energy, and ( $C_{\varepsilon 1}, C_{\varepsilon 2}, C_\mu$ ) model coefficients, respectively, Durbin (1996). The above-presented set of equations represents a fully closed system of PDEs that can provide a detailed spatial and temporal evolution of the velocity, pressure, turbulent kinetic energy, and dissipation rate over complex urban areas.

Next, to include effects of the atmospheric chemistry, we adopt the generic reaction set (GRS) model. This model is an extension of the classical NO<sub>x</sub>/O<sub>3</sub> photochemical steady-state model, by considering so-called reactive organic compounds (ROC). The GRS atmospheric chemistry model of Azzi and Johnson (1992) contains seven chemical reactions, three chemical species, and four pseudo-components, which are groups of species with similar chemical structures, and reactivity, and is illustrated in Fig. 1.



**Figure 1.** The schematic representation of the generic reaction set (GRS) model

The chemical reactions in the GRS model are listed as:



The added species in this model, compared to the NO<sub>x</sub>/O<sub>3</sub> photochemical steady-state model are ROC (Reactive Organic Compound; grouped category of organic components), RP (Radical Pool; grouped category of radical species), SGN (grouped category of Stable Gaseous Nitrogen compounds), and S(N)GN (grouped category of Stable Non-Gaseous Nitrogen compounds). In addition to the NO<sub>x</sub>/O<sub>3</sub> photochemical steady-state model, radicals are formed under the presence of ultraviolet light and ROC. Note that the chemical reaction mechanisms and corresponding kinetic parameters are provided from the smog chamber experiments, and reaction rate coefficients are listed in Table 1. The final corresponding set of PDEs makes the closed system of chemical reactions that can be integrated with the CFD through obtained velocity and turbulence fields.

**Table 1.** Values of the reaction rate coefficients of the GRS model, Azzi and Johnson (1992).

Rate constant	Value	Unit
$k_1$	0.0081	$\text{s}^{-1}$
$k_2$	$\approx \infty$	$\text{ppm}^{-2}\text{s}^{-1}$
$k_3$	0.37	$\text{ppm}^{-1}\text{s}^{-1}$
$k_4$	0.0025	$\text{s}^{-1}$
$k_5$	204	$\text{ppm}^{-1}\text{s}^{-1}$
$k_6$	167	$\text{ppm}^{-1}\text{s}^{-1}$
$k_7$	2	$\text{ppm}^{-1}\text{s}^{-1}$
$k_8$	2	$\text{ppm}^{-1}\text{s}^{-1}$

## NUMERICAL METHOD

In the current work, we use the finite volume method (FVM) to discretize the system of PDEs within our in-house code, Kenjeres et al. (2015). The general form of all transport equations (CFD + GRS) is of the time-rate-of-change/convection/diffusion (turbulent) /source or sink type and can be written as:

$$\int_V \frac{\partial \Phi}{\partial t} dV = \int_S \left( \Gamma_\Phi \frac{\partial \Phi}{\partial x_j} - \Phi U_j - \overline{\Phi u_j} \right) n_j dS \pm \int_V S_\Phi dV \quad (9)$$

where, the “ $\Phi$ ” is an arbitrary transport variable (e.g., the averaged velocity ( $U_j$ ) or concentration of species ( $C^{(n)}$ ), with  $n = \text{NO}, \text{NO}_2, \text{O}_3$ , etc.);  $dV$  is the volume of the numerical mesh segment;  $dS$  is the surface of the cell-face of the numerical mesh segment;  $n_j$  is unit vector perpendicular to the cell-face of the mesh segment;  $\phi u_j$  is the correlation representing interactions between fluctuating components, i.e. turbulence contributions. The diffusive terms are discretized by the second-order central-differencing scheme (CDS), whereas the convective terms are represented as second-order linear (LUDS) or quadratic upwind differencing (QUDES) schemes. Coupling between the velocity and pressure is calculated iteratively with the Semi-Implicit Method for Pressure Linked Equations (SIMPLE).

## RESULTS AND DISCUSSION

To illustrate the potential of the developed integrated CFD/GRS approach, we address a current situation along busy streets in the city of Rotterdam, The Netherlands. The Fig.2. shows the simulated case in the global and local Google Earth coordinates, starting from the regional scale (The Netherlands), city scale (Rotterdam), neighborhood scale (the ‘Oude Noorden’) scale, till the final street(s) scale (with a resolution of  $1\text{--}2\text{ m}^3$ ). The emission sources (due to intensive traffic along 3 streets) are marked in red. The region within the yellow box is geometrically reconstructed and simulated in detail, Fig.2.

The simulated CFD domain with imposed boundary conditions is shown in Fig.3. The INLET boundary conditions are imposed to mimic selected meteorological conditions that include the wind intensity, its direction, and intensity of wind fluctuations (turbulence). We impose the incoming wind with the intensity of  $2\text{ m/s}$  coming from the West. The turbulence intensity is  $5\%$ . The OUTLET boundary assumes a zero-gradient condition (in the wind direction) for all variables. The SYMMETRY boundaries impose that there is no flow perpendicular to the boundary. The red segments indicate the main traffic emission sources (roads). The numerical mesh used is also shown in characteristic planes (in total,  $5.4 \times 10^6$  control volumes are used for computations. The street emission rates of pollutants are imposed to mimic intensive traffic conditions:  $\text{NO} - 5 \times 10^{-2}\text{ ppm/s}$ ,  $\text{NO}_2 - 5 \times 10^{-3}\text{ ppm/s}$ ,  $\text{ROC} - 5.5 \times 10^{-3}\text{ ppm/s}$ . The background ozone concentration was specified to be:  $\text{O}_3 - 0.02\text{ ppm/s}$ .

Fig.4 shows the resulting contours of the concentrations of  $\text{NO}$  (a),  $\text{NO}_2$  (b), and  $\text{O}_3$  (c) at the pedestrian level ( $2\text{ m}$  above the ground) for the geometry and flow conditions shown in the previous figure. It can be seen that  $\text{NO}$  and  $\text{NO}_2$  show some local variations along the street under the influence of the local flow and turbulence disturbances originating from side streets and the presence of buildings, Fig.4 (a,b). In contrast, the  $\text{O}_3$  distribution is the result of a complex interplay

of the chemical reactions, local turbulence, and flow (i.e. local mixing), and strongly depends on the wind direction and configuration of surrounding buildings.

To make simpler navigation and interpretation of results, the calculated local concentrations of  $\text{NO}_2$  and  $\text{O}_3$  are also integrated with the Google Earth viewer, as shown in Fig.5, Liu and Kenjeres (2017). This enables easy and intuitive navigation among large-size complex data sets, with a precise zoom-in on particular locations, which is of importance for the local city planners and regulators.

This is illustrated further in Fig.6, where we have introduced a dense network of virtual concentration sensors, which can be then compared with the local measurements, Liu and Kenjeres (2017). In real situations, a very limited number of sensors is usually available within a street or local neighborhood, stressing the importance and potential of the presented simulation approach. The virtual sensors are shown as discrete volume objects (here we use simple blocks), which size and color are proportional to the local concentration of species at given locations. This enables easy observation of the critical location with significantly elevated levels of pollution.

## CONCLUSIONS

We demonstrated the potential of an integrated computational fluid dynamics approach with an atmospheric chemistry model in predicting the local pollution levels within the complex urban area. The presented approach is recommended as a basic foundation for further model developments that can include the presence of green areas (vegetation), complex terrains (hills), or rivers.

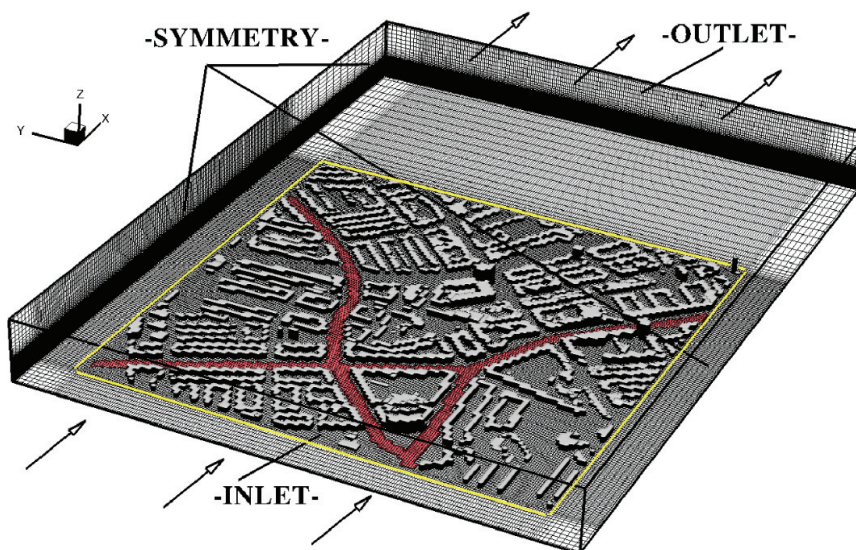
## REFERENCES

- Azzi M. C. M. and Johnson G. M. (1992), *An introduction to the generic reaction set photochemical smog mechanism*, Proceedings of the 11th International Conference of the Clean Air Society of Australia and New Zealand, Vol. 3, pp. 451-462.
- Durbin P. A. (1996), *On the k-e Stagnation Point Anomaly*, Int. J. Heat and Fluid Flow, Vol. 17, pp. 89-90.
- Kenjereš S. and K. Hanjalić K. (2009), *Tackling Complex Turbulent Flows with Transient RANS*, Fluid Dynamics Research, vol. 41, no. 012201, pp. 1-32.
- Kenjereš S., de Wildt S., and Busking T. (2015), *Capturing Transient Effects in Turbulent Flows over Complex Urban Areas with Passive Pollutants*, Int. J. Heat and Fluid Flow, Vol. 51, pp. 120-137.
- Liu D. and Kenjereš S. (2017), *Google-Earth Based Visualizations for Environmental Flows and Pollutant Dispersion in Urban Areas*, Int. J. Environmental Research and Public Health, vol. 14, no. 3, pp. 1-16.
- Muilwijk C., Schrijvers P., Wuerz S., and Kenjereš S. (2016), *Simulations of photochemical smog formation in complex urban areas*, Atmospheric Environment, Vol. 47, pp. 470-484.

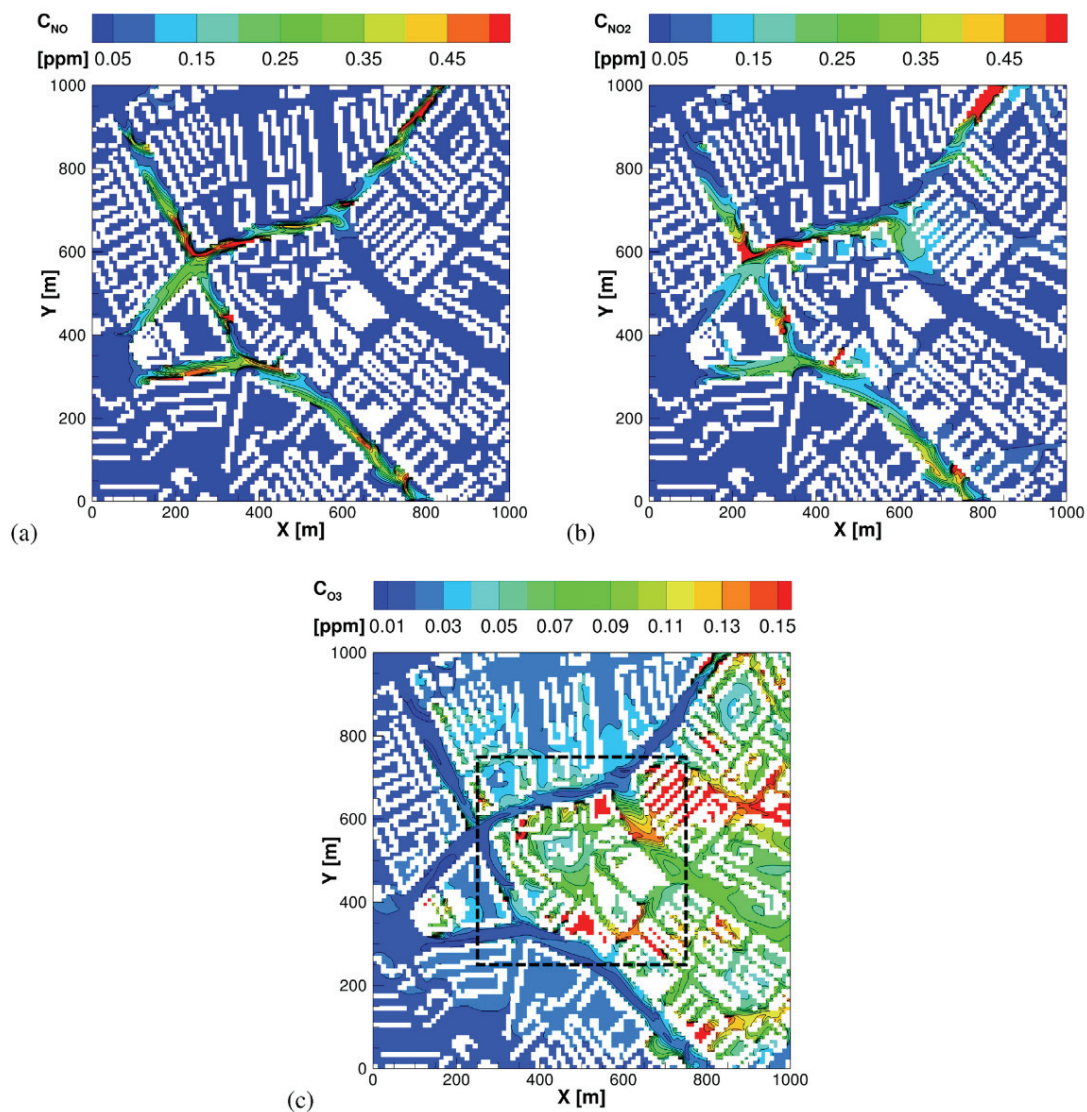




**Figure 2.** The simulated case is shown in the Google Earth: region (The Netherlands) scale; city (Rotterdam) scale and neighborhood (the “Oude Noorden”,  $2 \times 2 \text{ km}^2$ ) scale including computational mesh and blocks (~1800 blocks are included in simulations) representing parts of buildings. The emission sources (due to intensive traffic along 3 streets) are marked in red. The region within the yellow box is geometrically reconstructed and simulated in detail, Liu and Kenjeres(2017).

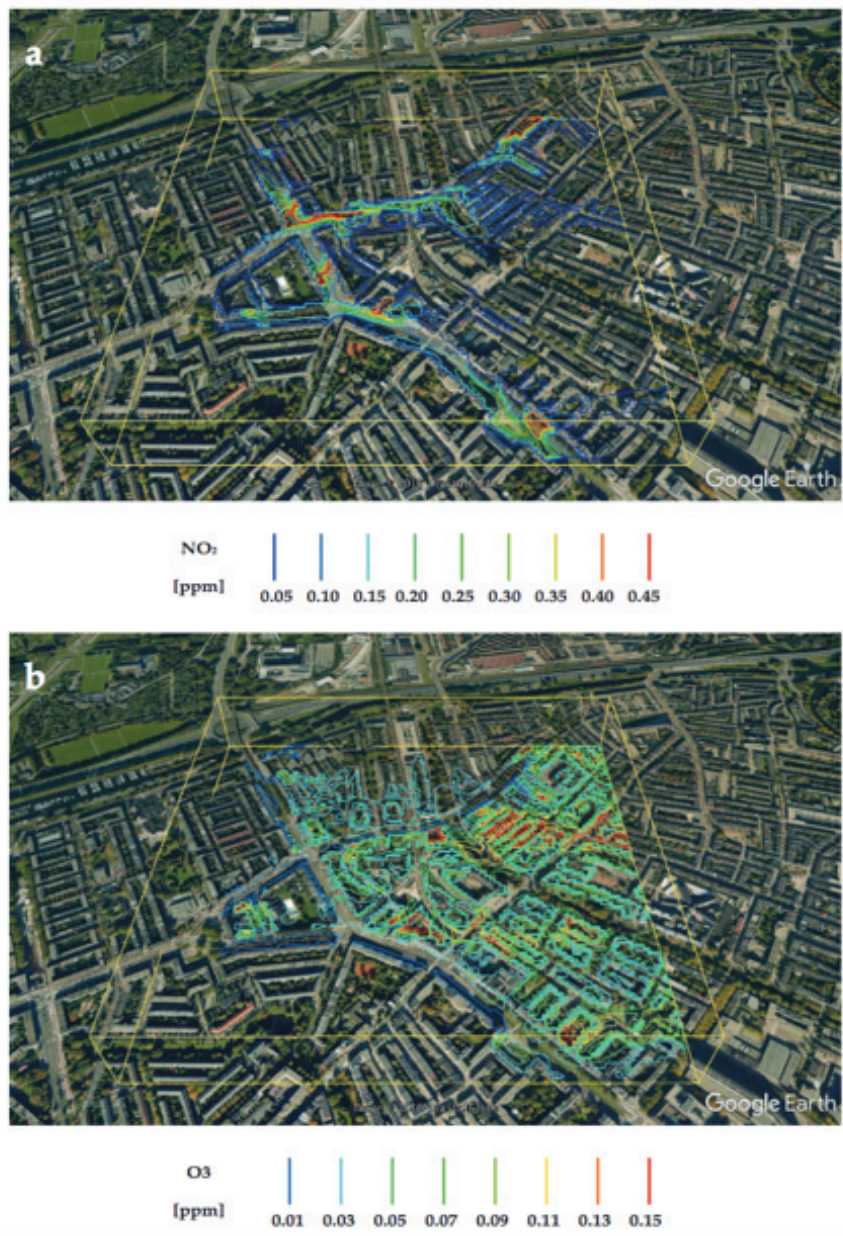


**Figure 3.** The simulated CFD domain with buildings, streets with intensive traffic emission (red segments), with imposed boundary conditions (INLET, OUTLET, SYMMETRY). The numerical mesh used is also shown in characteristic (x-y), (x-z), and (y-z) planes (in total,  $5.4 \times 10^6$  control volumes are used for computation, with numerical mesh refinements in the proximity of ground and buildings).

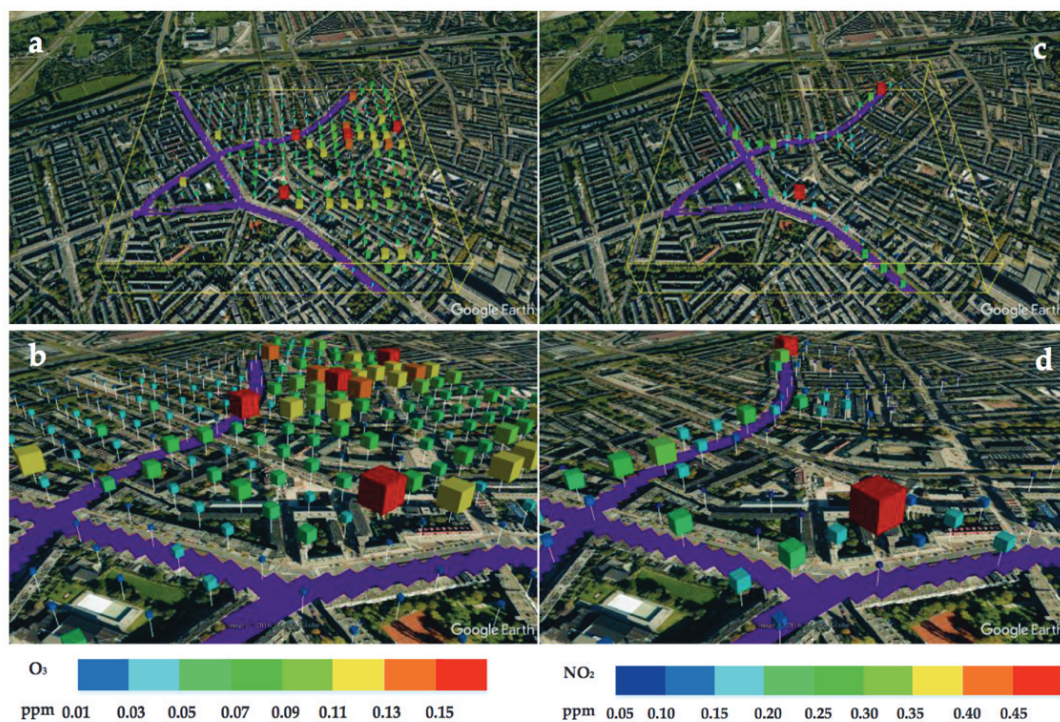


**Figure 4.** The contours of the concentrations of NO (a), NO<sub>2</sub> (b), and O<sub>3</sub> (c) at the pedestrian level (2 m above the ground) for the geometry and flow conditions shown in the previous figure (the wind direction is from the left to right,  $U_{in} = 2\text{ m/s}$ ), Muilwijk et al. (2016).





**Figure 5.** The mapping of pollution by isolines: (a) concentration contours of NO<sub>2</sub> (indicating the locations with high emission sources, i.e., traffic) and (b) concentration contours of O<sub>3</sub> (indicating locations with enhanced ozone distribution as the result of the atmospheric chemical reactions)—both in the horizontal plane at pedestrian level ( $z = 2\text{ m}$ ), Liu and Kenjeres (2017).



**Figure 6.** The virtual concentration sensors are generated as discrete volume objects, which size and color are proportional to the concentrations of species at given locations. Concentrations of:  $O_3$  (a,b);  $NO_2$  (c,d) across the whole domain or for particular streets, respectively, Liu and Kenjeres (2017).





JOANA DUARTE<sup>1</sup>  
JACQUELINE CASTELO  
BRANCO<sup>2</sup>  
FERNANDA RODRIGUES<sup>3</sup>  
JOÃO SANTOS BAPTISTA<sup>4</sup>

<sup>1,2,4</sup>Laeta-proa, University of Porto,  
Portugal

<sup>3</sup>Risco, University of Aveiro,  
Portugal

<sup>1</sup>jasduarte@fe.up.pt

<sup>2</sup>jcb@fe.up.pt

<sup>3</sup>mfrodrigues@ua.pt

<sup>4</sup>jsbap@fe.up.pt

## SURFACE MINING ENVIRONMENTAL IMPACTS AND THEIR MANAGEMENT – A SHORT REVIEW

**Abstract:** *Despite being a crucial activity for society, it is known that mining exploitation encompasses several impacts, from water contamination to land degradation, greenhouse gas emissions and biodiversity loss. Neighbouring populations can also be affected, especially by superficial exploitation. Thus, the main objective of this short review was to find evidence of environmental aspects related to surface exploitation activities and possible ways of mitigating them. The Preferred Reporting of Items for Systematic Reviews and Meta-Analyses guidelines were used to build the research strategy and report the results. The exclusion criteria were publication date, document type and source, and publication language. Then, the title, abstract and keywords were assessed to determine possible inclusion whenever the works were related to any rationale focused on environmental aspects or impacts and mitigation measures for surface mining. Gas emissions, dust, noise, vibrations, as well as water, soil and landscape degradation, were categorized according to the population affected (people, fauna or flora), their effects and mitigation options. A total of 5,712 articles were identified, from which 33 were included in the short review. The literature analysis showed that the most-reported impact was dust (in nearly half of the studies), affecting the air quality that often leads to breathing ailments in humans. Special attention was also paid to landscape impacts such as forest degradation, loss of visual integrity and habitat destruction. The proposed mitigation measures were related to equipment inspection, road maintenance and soil remediation. Overall, several aspects and impacts were identified due to mining activities. Nonetheless, environmental safety management is typically based on remediation measures rather than prevention actions.*

**Keywords:** mining, environmental safety, environmental impacts, surface exploitation

## INTRODUCTION

The intensive and daily usage of mineral resources is the well-being foundation for today's (developed) societies, putting the mining industry (MI) at the top of the most relevant sectors worldwide (Bag, 2020). The growing technological needs are pressuring the industry to be more efficient, producing more and in a faster way.

MI comprises extraction and processing activities of the mineral resources provided by nature, including water. However, due to the exploitation of finite resources, this industry is also connected with severe socio-environmental consequences in the long term (Pal, 2019, Iladie, 2021). While surface operations are usually preferred due to lower operating costs, the land degradation impact in this type of exploitation can be up to 11 times higher than underground exploitation (Wang, 2018).

Surface exploitation (quarry or mine) can be divided into several phases: topsoil removal and soil preparation, hillside or open-pit exploitation (that can be decomposed into several other secondary activities), environmental recovery and site closure (and monitoring).

In order to be economically viable, environmentally sustainable and socially responsible, exploitation should be planned and designed considering the following parameters: mineral characteristic, deposit characterisation, transport, production, mine parameters, ore and overburden flow, cost, profit, investment, air pollution, waste quantity, water contamination, noise, negative impact on the soil, energy efficiency, company staff (Rakhmangulov, 2021). Thus, this short review aimed to find evidence of environmental aspects related to surface exploitation activities and possible ways of mitigating them.

## METHODOLOGY

The Preferred Reporting of Items for Systematic Reviews and Meta-Analyses guidelines (PRISMA) were used to conduct the research and report of this short review (Page, 2021, Moher, 2009). The following Boolean research expression was used in Scopus, INSPEC, Science Direct, Web of Science, Dimensions (databases): (“environmental risk” OR “environmental impact” OR “ecological impact” OR “environmental aspect” OR “social impact” OR “corporate responsibility” OR “green mining” OR sustainability) AND (quarry OR “open pit” OR “open cast” OR “surface mining” OR “extractive industry”). The exclusion criteria used were: 1) publication date – articles published prior 2017, 2) document type – articles other than research, 3) document source – source other than peer-review journals, and 4) publication language – other than English. Title, abstract and keywords were assessed to determine the possible inclusion of works related to environmental

aspects or impacts, and mitigation measures for surface exploitation. An excel table was built to organise and process the collected information. This table was divided into the environmental aspects of mining activities: gas emissions, dust, noise, vibration, water, soil and landscape. Data collection focused on: who is affected (people, fauna or flora), possible effects and mitigation measures. The research was performed in March 2022.

## RESULTS AND DISCUSSION

A total of 5,712 articles were identified, from which 2,973 were excluded due to date, 603 because of the document type, 3 concerning source type, 109 were excluded due to publication language, and 1,777 were out of topic. Of the 247 remaining papers, 93 were duplicate records and removed. After analysing the articles against the eligibility criteria, 33 were included in the study.

Figure 1 summarises the research process.

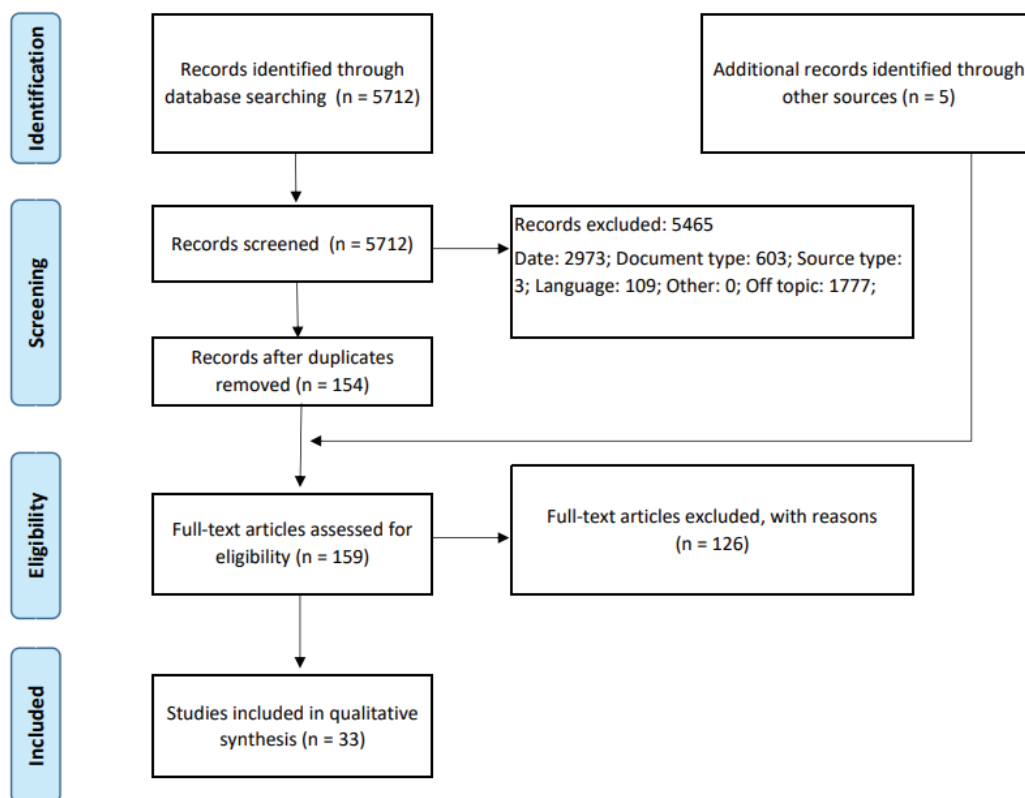


Figure 1. Research flow-diagram adapted from PRISMA [6,7]

As mentioned above, the collected research considered gas emissions, dust, noise, vibration, and water, soil and landscape degradation.

Greenhouse gases such as carbon dioxide (CO<sub>2</sub>), nitrogen oxides (NO<sub>x</sub>), and methane (CH<sub>4</sub>) were found to be emitted from exploitation activities (Melodi, 2017, Guimaraes da Silva, 2018, Asif, 2019, Bendouma, Penaranda Barba, 2021, Vandana, 2020). Nonetheless, their potential effect was not investigated.

The most-reported impact due to mining activities was dust (in 16 of the total 33 included papers), which affects air quality (Yadav, 2020), causes breathing ailments in surrounding populations (Penaradna 2021, Vandana,2020), and provokes dust deposition (Penaradna 2021, Vandana,2020).

Noise pollution affecting workers, surrounding communities and wildlife was also stated (Melodi,

2017), though no other concern was found within the literature.

Concerning vibration, the felt effects were typically related to human discomfort (Vavarro Torres, 2018) and build damage (Pal, 2019, Vandana, 2020).

The overall impacts on the water were related to changes in its quality (Iladie, 2021, Penaranda Barba, 2021), damage to aquatic organisms (Ahmed, 2020), dust contaminated water (Pal, 2019), high levels of sulphur, nickel, nitrates (Borden, 2022) and arsenic (Porgo, 2017), general pollution (Melodi, 2017) and oil spilling due to equipment usage (Iladie, 2021, Penaranda Barba, 2021).

Landslides (Vandana, 2020), loss of soil quality (Penaranda Barba, 2021), nutrient depletion (Vandana, 2020), increased erosion risk (Vandana, 2020) and destruction of fauna and flora habitat conditions (Melodi, 2017, Gul, 2019) were the primary identified effects on soil.

Almost half of the articles (15 out of 33) described landscape issues. Deforestation (Vandana, 2020, Ross, 2021, Kiro, 2017, Milanovic, 2017), forest degradation (Dubey, 2011), habitats destruction (Penaranda Barba, 2021, Vandana, 2020, Xiang, 2021, Becker, 2015), landscape degradation (Chatterjee, 2021), loss of visual integrity (Vandana, 2020) and land occupation due to waste disposal (Yuan, 2021).

With these effects put out in the open, the potential mitigation measures and environmental safety management were analysed. However, this time, gaseous emissions were left out of the equation as no article mentioned any attenuating measure.

Regarding dust, the measures include maintaining soil moisture (Penaranda Barba, 2021), regular ground wetting (Penaranda Barba, 2021) and water spray use (Yadav, 2020, Kim, 2021) to diminish the probability of dust resuspension due to transportation activities. Road maintenance (Penaranda Barba, 2021) and planning activities according to the meteorological factors (Penaranda Barba, 2021, Wang, 2022) were also measures pointed out by the authors. Nonetheless, these measures do not take into consideration the effects on surrounding populations. Preventing dust resuspension may certainly be an important action, but it does not necessarily improve air quality.

In relation to noise, only two points were mentioned: equipment periodic inspection (Penaranda Barba, 2021) and activity planning, so the noisiest operations do not coincide (Penaranda Barba, 2021). Again, these two measures are primarily beneficial for workers, with no particular benefit for fauna or other populations.

The situation is even worse when analysing what the literature reports as a mitigating measure against vibration effects: blasting design adjustment (Navarro Torres, 2018). Although this may actually have a positive consequence on community and overall fauna, thereport on this measure is too brief and too vague.

Appropriate storage of dangerous substances (Iladie, 2021), equipment periodic maintenance to avoid accidental fuel leakage (Iladie, 2021), and manipulating fuels in specially designed sites (Iladie, 2021), phosphorus amendment (Gamez, 2019) are the only referred actions to prevent accidental water contamination. Important considerations regarding raw material processing and other water-use activities are not even considered in the included articles.

One study suggested that soil (and vegetation) removal must be done progressively and slowly (Penaranda Barba, 2021). However, this was the only time any of studies included to mention mitigating actions related to soil.

Finally, considering effects to the landscape it was concluded that vulnerable areas should be identified prior to exploitation to adequately address and prevent upcoming issues (Vandana, 2020). Topsoil should be removed, stockpiled and adequately maintained, preventing any unnecessary landscape degradation (Penaranda Barba, 2021). Additionally, a slope aging product should be applied to improve the appearance of the general slopes (Penaranda Barba, 2021).

Interestingly, most of the problems that these anticipated measures target afterwards the undesired event, can actually be prevented with an adequate operation plan and design.

## CONCLUSIONS

Despite being a vital sector in the worldwide economy and overall societal development, the mining industry still faces several socio-environmental challenges, one of which is environmental degradation.

This short review aimed to find evidence of environmental aspects related to surface exploitation activities and possible ways of mitigating them. Though literature points out that mineral resources extraction has consequences such as greenhouse gas emissions, dust, noise, vibration, soil and landscape degradation and water contamination, the reported effects on workers, general population, fauna and flora, most of the time barely scratch the surface of the problem. The scenario is not that different when analysing possible mitigating solutions related to environmental management. Moreover, the described solutions are not in line with the felt effects, despite they do indicate the possible course of action. To conclude, despite the apparent widespread knowledge on the environmental consequences of mineral exploitation, still there is a lack of adequate engineering management-based mitigation measures.

## REFERENCES

Ahmed, Z.; Alam, R.; Akter, S.A.; Kadir, A. (2020). 'Environmental sustainability assessment due to stone quarrying and crushing activities in Jaflong, Sylhet', *Environ. Monit. Assess.*, 192, 778, doi:10.1007/s10661-020-08754-9.

- Asif, Z.; Chen, Z. (2019). 'An integrated optimization and simulation approach for air pollution control under uncertainty in open-pit metal mine', *Front. Environ. Sci. Eng.* 13, 74, doi:10.1007/s11783-019-1156-x.
- Bag, S.; Yadav, G.; Wood, L.C.; Dhamija, P.; Joshi, S. (2020). 'Industry 4.0 and the circular economy: Resource melioration in logistics', *Resour. Policy* 68, 101776, doi:10.1016/j.resourpol.2020.101776.
- Becker, D.A.; Wood, P.B.; Strager, M.P.; Mazzarella, C. (2015). 'Impacts of mountaintop mining on terrestrial ecosystem integrity: identifying landscape thresholds for avian species in the central Appalachians, United States', *Landsc. Ecol.* 30, 339–356, doi:10.1007/s10980-014-0134-8.
- Bendouma, S.; Serradj, T.; Vapur, H. 'A case study of the life cycle impact of limestone quarrying on the environment', *Int. J. Glob. Warm.* 22, 432–47.
- Borden, R.K.; Brown, P.L.; Sturgess, S. (2022). 'Geochemical and hydrological evolution of mine impacted waters at the Argyle Diamond Mine, Western Australia', *Appl. Geochemistry*, 139, 105253, doi:10.1016/j.apgeochem.2022.105253.
- Chatterjee, S. (2021). 'Impact of open pit coal mining on the forest landscape ecology using spatial metrics: a study of Barabani C.D. block, West Bengal', *Spat. Inf. Res.* 29, 645–659, doi:10.1007/s41324-021-00382-w.
- Dubey, K.; Dubey, K.P. (2011). 'Impact of mining on tree diversity of the silica mining forest area at Shankargarh, Allahabad, India', *J. For. Res.* 22, 527–532, doi:10.1007/s11676-011-0172-x.
- Gámez, O.R.; Laffont-Schwob, I.; Prudent, P.; Vassalo, L.; Rodriguez, I.A.; Macías, R.P.; Petit, M.E.; Ibarra, A.T.A.; Masotti, V.; Perraud-Gaime, I.; et al. (2019). 'Assessment of water quality from the Blue Lagoon of El Cobre mine in Santiago de Cuba: a preliminary study for water reuse', *Environ. Sci. Pollut. Res.* 26, 16366–16377, doi:10.1007/s11356-019-05030-3.
- Guimarães da Silva, M.; Costa Muniz, A.R.; Hoffmann, R.; Luz Lisbôa, A.C. (2018). 'Impact of greenhouse gases on surface coal mining in Brazil', *J. Clean. Prod.* 193, 206–216, doi:10.1016/j.jclepro.2018.05.076.
- Gül, M.; Zorlu, K.; Gül, M. (2019). 'Assessment of mining impacts on environment in Muğla-Aydın (SW Turkey) using Landsat and Google Earth imagery', *Environ. Monit. Assess.* 191, 655, doi:10.1007/s10661-019-7807-3.
- Iladie, C.M. (2021). 'The Impact of Exploiting Lignite in Lupoia Open Pit on Environmental Water', *Min. Rev.* 27, 76–83, doi:10.2478/minrv-2021-0018.
- Kim, M.K.; Jang, Y.; Heo, J.; Park, D. (2021). 'A UAV-based air quality evaluation method for determining fugitive emissions from a quarry during the railroad life cycle', *Sensors*, 21, doi:10.3390/s21093206.
- Kiro, A.; Paliwal, H.B.; Mohapatra, A.K. (2017). 'Impact Assessment Of Mining Activities On Tree Diversity At Limestone & Dolomite Mining Area – BSLC Mines, Biramitrapur, Odisha', *J. Pharmacogn. Phytochem.* 6, 1902–1905.
- Melodi, M.M. (2017). 'Assessment of Environmental Impacts of Quarry Operation in Ogun State, Nigeria', *J. Eng. Technol.* 2, 100–103.
- Milanović, M.; Tomić, M.; Perović, V.; Radovanović, M.; Mukherjee, S.; Jakšić, D.; Petrović, M.; Radovanović, A. (2017). 'Land degradation analysis of mine-impacted zone of Kolubara in Serbia', *Environ. Earth Sci.* 76, doi:10.1007/s12665-017-6896-y.
- Moher, D.; Liberati, A.; Tetzlaff, J.; Altman, D.; Altman, D.; Antes, G.; Atkins, D.; Barbour, V.; Barrowman, N.; Berlin, J.; et al. (2009). 'Preferred reporting items for systematic reviews and meta-analyses: The PRISMA statement', *PLoS Med.* 6, doi:10.1371/journal.pmed.1000097.
- Navarro Torres, V.F.; Silveira, L.G.C.; Lopes, P.F.T.; de Lima, H.M. (2018). 'Assessing and controlling of bench blasting-induced vibrations to minimize impacts to a neighboring community', *J. Clean. Prod.* 187, 514–524, doi:10.1016/j.jclepro.2018.03.210.
- Page, M.J.; McKenzie, J.E.; Bossuyt, P.M.; Boutron, I.; Hoffmann, T.C.; Mulrow, C.D.; Shamseer, L.; Tetzlaff, J.M.; Akl, E.A.; Brennan, S.E.; et al. (2021). 'The PRISMA 2020 statement: An updated guideline for reporting systematic reviews', *PLOS Med.* 18, e1003583
- Pal, S.; Mandal, I. (2019). 'Impact of aggregate quarrying and crushing on socio-ecological components of Chottanagpur plateau fringe area of India', *Environ. Earth Sci.* 78, 661, doi:10.1007/s12665-019-8678-1.
- Peñaranda Barba, M.A.; Alarcón Martínez, V.; Gómez Lucas, I.; Navarro Pedreño, J. (2021). 'Mitigation of Environmental Impacts in Ornamental Rock and Limestone Aggregate Quarries in Arid And Semi-arid Areas', *Glob. J. Environ. Sci. Manag.* 7, 565–586, doi:10.22034/gjesm.2021.04.06.
- Porgo, M.; Gokyay, O. (2017). 'Environmental impacts of gold mining in Essakane site of Burkina Faso', *Hum. Ecol. Risk Assess.* 23, 641–654, doi:10.1080/10807039.2016.1263930.
- Rakhmangulov, A.; Burmistrov, K.; Osintsev, N. (2021). 'Sustainable Open Pit Mining and Technical Systems: Concept, Principles, and Indicators', *Sustainability*, 13, 1101, doi:10.3390/su13031101.
- Ross, M.R.V.; Nippgen, F.; McGlynn, B.L.; Thomas, C.J.; Brooks, A.C.; Shriver, R.K.; Moore, E.M.; Bernhardt, E.S. (2021). 'Mountaintop mining legacies constrain ecological, hydrological and biogeochemical recovery trajectories', *Environ. Res. Lett.* 16, doi:10.1088/1748-9326/ac09ac.
- Vandana, M.; John, S.E.; Maya, K.; Sunny, S.; Padmalal, D. (2020). 'Environmental impact assessment (EIA) of hard rock quarrying in a tropical river basin—study from the SW India', *Environ. Monit. Assess.* 192, 580, doi:10.1007/s10661-020-08485-x.
- Vandana, M.; John, S.E.; Maya, K.; Padmalal, D. (2020). 'Environmental impact of quarrying of building stones and laterite blocks: a comparative study of two river basins in Southern Western Ghats, India', *Environ. Earth Sci.* 79, 1–15, doi:10.1007/s12665-020-09104-1.
- Wang, Z.; Zhou, W.; Jiskani, I.M.; Luo, H.; Ao, Z.; Mvula, E.M. (2022). 'Annual dust pollution characteristics and its prevention and control for environmental protection in surface mines', *Sci. Total Environ.* 825, 153949, doi:10.1016/j.scitotenv.2022.153949.
- Wang, H.; Zhang, B.; Bai, X.; Shi, L. (2018). 'A novel environmental restoration method for an abandoned limestone quarry with a deep open pit and steep palisades: a case study', *R. Soc. Open Sci.* 5, 180365, doi:10.1098/rsos.180365.
- Xiang, H.; Wang, Z.; Mao, D.; Zhang, J.; Zhao, D.; Zeng, Y.; Wu, B. (2021). 'Surface mining caused multiple ecosystem service losses in China', *J. Environ. Manage.* 290, 112618, doi:10.1016/j.jenvman.2021.112618.
- Yadav, S.K.; Jain, M.K. (2020). 'Variation in concentrations

of particulate matter with various sizes in different weather conditions in mining zone', *Int. J. Environ. Sci. Technol.*, 17, 695–708, doi:10.1007/s13762-019-02313-7.

Yuan, D.; Hu, Z.; Yang, K.; Guo, J.; Li, P.; Li, G.; Fu, Y. (2021). 'Assessment of the Ecological Impacts of Coal Mining and Restoration in Alpine Areas: A Case Study of the Muli Coalfield on the Qinghai-Tibet Plateau', *IEEE Access*, 9, 162919–162934, doi:10.1109/ACCESS.2021.3133478.

## **ACKNOWLEDGEMENTS**

This work was supported by Fundação para a Ciência e a Tecnologia (FCT) through INEGI, under LAETA (PROA) project SFRH/BD/143241/2019. The authors would also like to acknowledge the Doctoral Program in Occupational Safety and Health from the Faculty of Engineering of the University of Porto for their support and funding.

## **BIOGRAPHY of the first author**

### **Prof. Dr. Joana Duarte**

Dr. Joana Duarte, graduated from the Faculty of Engineering of Porto, holding a double Master's degree in Mining Engineering and Occupational Safety and Hygiene Engineering.



She completed her PhD in the Doctoral Program on Occupational Safety and Health at the same institution, working primarily on prevention through design in the Extractive Industry. She is currently an Invited Assistant Professor at the Faculty of Engineering of the University of Porto and the International Journal of Occupational and Environmental Safety journal manager. She joined the Sociedade Portuguesa de Segurança e Higiene Ocupacionais (SPOSHO) technical committee in occupational safety matters in 2022. She is also part of the Board of Directors of the Associação Ibero-Americana de Engenharia de Segurança no Trabalho since 2019. She has over 40 published works..



# OESEM

19<sup>th</sup> INTERNATIONAL CONFERENCE  
"MAN AND WORKING ENVIRONMENT"

OCCUPATIONAL AND ENVIRONMENTAL SAFETY  
ENGINEERING & MANAGEMENT

## *Occupational Safety Engineering and Management*







MONIKA LUTOVSKA<sup>1</sup>  
VLADIMIR MIJAKOVSKI<sup>2</sup>

<sup>1</sup>Mother Teresa University in Skopje,  
Faculty of Technical Sciences

<sup>2</sup>University "St. Kliment Ohridski"  
Faculty of Technical Sciences, Bitola

<sup>1</sup>monika.lutovska@unt.edu.mk  
<sup>2</sup>vladimir.mijakovski@tfb.uklo.edu.mk

## OCCUPATIONAL SAFETY AND HEALTH STATISTICS WITHIN THE SUSTAINABILITY AGENDA

**Abstract:** *This paper analyzes the situation with occupational safety in the Republic of North Macedonia, including non-fatal and fatal accidents at work in the last decade (2010-2021). According to the official data published in the annual reports of the Macedonian Occupational Safety and Health Association (MOSHA) and statistical data processing, there were a total of 1,708 accidents at work in the last decade, out of which, unfortunately, 23.30%, or 398 accidents, ended fatally. By far the most numerous were the accidents in Public Administration and Defence, 461, but with the lowest mortality rate of 5.21%. On the other hand, 259 accidents were registered with Households during the entire period, but the mortality reached as much as 51.74%, which is an extremely high number. Construction is also a characteristic sector, where 25.40% out of a total of 315 accidents were deaths. These data are even more alarming given that a large number of accidents at work remain unregistered.*

*Improved sustainable concepts should improve the quality of workplaces and prevent injuries and deaths, which should be the primary goal of every employer. Social and economic benefits of better health and safety at work are the main objectives of a stronger national strategy, which will lead to many benefits, such as reduced healthcare costs and sick leave, and improved working methods.*

**Key words:** non-fatal accidents, deaths, occupational safety and health, sustainability agenda.

### INTRODUCTION

If the sustainability agenda, by definition, involves a strategy to meet the needs of the present without compromising the ability of future generations to meet their own needs in the future, then occupational safety has a clearly defined resource conservation platform, that fits right into the Rio Summit declaration (WHO, 1995). This platform is based on saving resources that have a particularly high value because they are human (Taubitz, 2010).

The importance of workplace safety is a crucial factor in the quality of life at both the individual and the collective level, so improved sustainable concepts should help create higher quality workplaces and prevent injuries and deaths, which should also be the primary goal of every employer (Eurostat, 2022). Relying on the Treaty establishing the European Economic Community, the 'Council directive 89/391/EEC' (1989), as a fundamental safety and health legal act, lays down the general principles concerning the prevention and protection of workers against occupational accidents and diseases. For safety and health purposes, this act contains specific principles for the assessment, prevention and elimination of risks and factors of accidents (Directive 89/391/EEC, 1989). Also, particular importance is

attached to the implementation of basic principles such as: information, consultation, balanced participation in accordance with national laws and practices, and training of workers and their representatives.

In accordance with the statement of the European Union's information agency for occupational safety and health (EU-OSHA) that poor occupational safety and health always involves financial costs, poor occupational health and reduced working capacity of workers may cause an economic loss of up to 10-20% of the Gross National Product of a country (WHO, 1995). Globally, occupational deaths, diseases and illnesses account for an estimated loss of about 4% of the Gross Domestic Product (GDP) (Amponsah-Tawiah, 2013). Particularly high rates of deaths, injuries and accidents at work are found not only in non-EU countries, but also in those that are in the EU, (Amponsah-Tawia & Mensah, 2016). Despite all the controls and measures being taken by the Labour Inspectorate and the publicly disclosed data by State Statistical Office, the Institute for Public Health, the Macedonian Occupational Safety and Health Association (MOSHA) and the Organization of Employers of North Macedonia (Lutovska et al., 2017), occupational related accidents, diseases and hazards are estimated to cost our country over €400 million (MOSHA, 2021).

Consequently, every employer is obligated to identify the hazards and risk factors related to work or working conditions, eliminate or reduce them and assess the effects of the remaining risks to the employees' health and safety (Anttonen and Pääkkönen, 2010). Among other things, employers should ensure the safety and health of workers in every aspect related to work and prepare reports and keep records of accidents at work that result in absence from work longer than three days (European Commission. European Statistics on Accidents at Work (ESAW), 2013).

## MATERIALS AND METHODS

### Accidents at work in the EU

In total, 3.1 million non-fatal accidents in the EU with at least four calendar days of absence from work occurred in 2019. Considering that the number of accidents registered as fatal is 3,408, a ratio of approximately 920 non-fatal accidents for every fatal one is obtained (Taubitz, 2010). Compared with 2018, there were additional 76 fatal accidents at work in the EU in 2019, which is equivalent to an increase of 2.3 % (Eurostat, 2022).

Moreover, it is obvious from the analysis by activity that the number of accidents at work varies greatly depending on the economic activity (Fig. 1). Thus, 43.9% of all accidents at work in 2019 were attributed to the construction, transport and storage, manufacturing and agriculture, forestry and fisheries sectors combined. Also, 64.4% of fatal accidents occurred in this group of sectors. Specifically, 22.2% of all fatal accidents at work in the EU are attributed to the construction sector, while about 15% pertain to transportation and storage. They are followed by manufacturing with 14.8% and agriculture, forestry and fishing with 12.5% (Eurostat, 2022).

In the NACE (Statistical classification of economic activities in the European Community) sections, double-digit shares of the total number of non-fatal accidents were recorded, whereby the manufacturing sector share was 18.7%, wholesale and retail 12.3 %, construction 11.8 %, and human health and social work activities 11.0 %.

Fatal and non-fatal accidents at work by NACE section, EU, 2019 (% of fatal and non-fatal accidents)

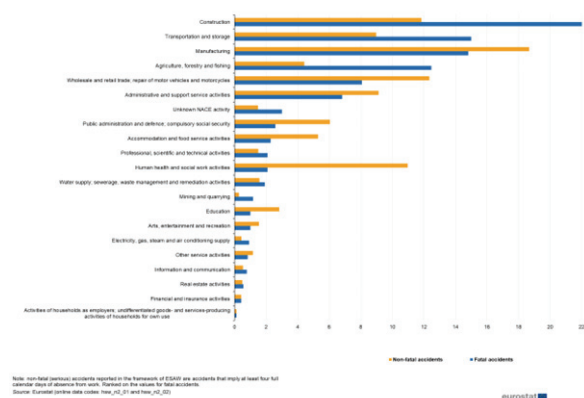


Figure 1. Fatal and non-fatal accidents at work by economic activity, EU-28, 2019 (Source: Eurostat)

The figures indicate that more than a fifth of all fatal accidents at work in the EU took place within the construction sector. Considering the research that showed the highest number of fatal accidents occurring in the construction sector in Europe, it is clear that the construction industry is the sector with the highest risk.

### Accidents at work in the Republic of North Macedonia

In 2007, North Macedonia adopted the Law on Occupational Safety and Health (Official Gazette of the Republic of Macedonia, No. 92/2007) and completely incorporated the provisions of 'Council directive 89/391/EEC' (1989), as a legal act for basic safety and health at work (European Commission. European Statistics on Accidents at Work (ESAW), 2013). According to the official data published in the annual reports of MOSHA (2010-2021), and statistical data processing, there were a total of 1,708 accidents at work in the last decade, out of which, unfortunately, 398, or 23.30%, ended fatally (Table 1).

Table 1. Accidents at work in North Macedonia in all sectors for the period from 2010 to 2021

Year	2010	2011	2012	2013	2014	2015
Non-fatal accidents	85	79	116	70	88	105
Fatal accidents	44	44	45	28	42	39
Year	2016	2017	2018	2019	2020	2021
Non-fatal accidents	94	134	124	153	127	135
Fatal accidents	19	24	33	25	25	30

The highest number of accidents at work, 178, occurred in 2019, whereby 14.04% were accidents with fatal outcomes, which is the lowest percentage of mortality in the entire analyzed decade. On the other hand, the highest mortality rate of 35.77% was recorded in 2011. In 2021, there was a slight increase in the number of accidents compared to 2020, but the fatality percentage of 16.45% in 2020 rose to 18.18% in 2021.

A decline was observed in 2016, when a total of 113 accidents at work were registered and 16.81% of them were deaths (Fig. 2).

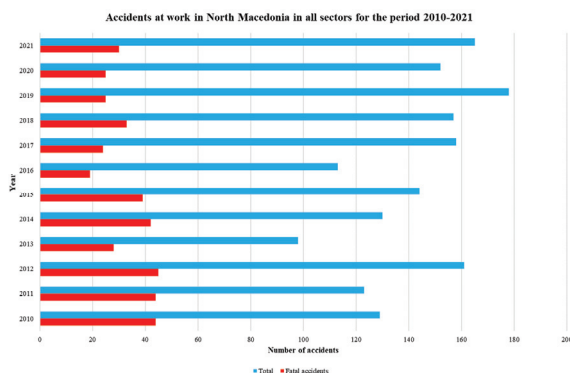


Figure 2. Total and fatal accidents in North Macedonia in the period from 2010 to 2021 in all sectors combined

Unfortunately, despite all the control measures being taken, North Macedonia still has a high incidence rate of fatal accidents at work, which amounts to 3.77 (out of every 100,000 employees, 3-4 die) for 2021 (Table 2) (MOSHA, 2010-2021).

**Table 2.** Incidence rate for injuries and fatal accidents in the period from 2010 to 2021

Year	2010	2011	2012	2013	2014	2015
Injuries	/	/	17.2	10.2	12.64	14.69
Fatal acc.	/	/	6.8	4.08	6.03	5.44
Year	2016	2017	2018	2019	2020	2021
Injuries	13	17.98	16.33	19.18	15.97	16.97
Fatal acc.	2.62	3.22	4.34	3.13	3.14	3.77

Although this is a lower rate in relation to 2012, when the country had a record incidence rate of 6.8, compared to some European countries such as the UK, where the incidence rate for fatal accidents at work is only 0.5 (MOSHA, 2010-2021), such low rates will be very difficult to reach.

Regarding the incidence rates of injuries, the obtained data suggest that they are far lower and incomparable to the injury rates in EU countries. The reason for this is that North Macedonia does not report accidents that result in injury and absence from work for more than three working days.

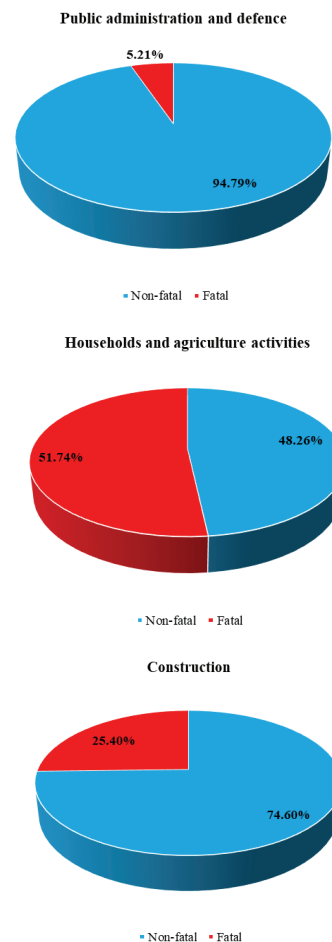
### RESULTS AND DISCUSSION

According to the National Classification of Activities in North Macedonia, the riskiest occupational sectors within the 2010-2021 period, were 'Public administration, Police and Defence', 'Households as employers and agricultural activities' and 'Construction sector' (Table 3).

**Table 3.** Accidents at work for occupational sectors with the highest risk in North Macedonia (2010 to 2021)

Year	Public administration, Police and Defence		Households as employers and agricultural activities		Construction sector	
	Total number of accidents	Fatal accidents	Total number of accidents	Fatal accidents	Total number of accidents	Fatal accidents
2010	26	0	22	16	17	6
2011	26	2	19	15	26	15
2012	45	0	19	17	28	3
2013	9	0	31	10	20	7
2014	47	5	23	17	12	5
2015	94	11	15	8	7	4
2016	46	0	23	9	18	6
2017	35	1	26	12	31	6
2018	31	2	22	10	39	8
2019	24	3	29	8	42	6
2020	35	0	20	8	36	5
2021	43	0	10	4	39	9

By far the most numerous were the accidents in Public Administration and Defence, 461, but with the lowest mortality rate of 24 deaths, or 5.21%. On the other hand, 259 accidents were registered with Households as employers and agricultural activities during the entire period, but the mortality reached as many as 134 cases, or 51.74%, which is an extremely high number. Construction is also a characteristic sector, where 80, or 25.40%, out of a total of 315 accidents were deaths (Fig. 3).



**Figure 3.** Occupational sectors with highest risk in the 2010-2021 period

The processed data indicate that out of the total number of accidents (1708) that occurred in the 2010-2021 period, the 'Public administration, Police and Defence' participated with 27%, 'Construction' with 18.44% and 'Households as employers and agriculture activities' with 15.16%.

However, the 'Households as employers and agriculture activities' sector has an extremely high percentage of deaths owing to the insufficient level of education, the use of child labour from an early age, as well as the low standard of living, because of which households are forced to do various types of work. These data are even more alarming given that a large number of accidents at work remain unregistered.

## CONCLUSION

Every life-sustaining process, production outcome and consumption endeavour should be sustainable through satisfying the human beings at the centre of the concept of sustainable development, as individuals entitled to a healthy and productive life in harmony with nature. Improved sustainable concepts should create higher-quality workplaces and prevent injuries and deaths. Social and economic benefits of better health and safety at work are the main objectives of a stronger national strategy, which will lead to many benefits, such as reduced healthcare costs and sick leaves, and improved working methods. Therefore, developing a strong culture of safety and health in our country should be achieved by a fully engaged leadership working together with a committed workforce toward the goal of zero injuries, illnesses and incidents.

In the EU, 43.9% of all accidents at work in 2019 were attributed to the construction, transport and storage, manufacturing and agriculture, forestry and fisheries sectors combined. Also, 64.4% of fatal accidents occurred in this group of sectors.

In North Macedonia, most accidents at work (178) occurred in 2019, of which 14.04% were fatal, but the highest fatality rate of 35.77% was registered in 2011. According to the National Classification of Activities in North Macedonia, most accidents occurred in 'Public Administration and Defence', 461, but with the lowest mortality rate of 24 deaths (5.21%), and 259 accidents occurred in 'Households as employers and agriculture activities', where the mortality reached as many as 134 cases (51.74%). In the 'Construction' sector, out of a total of 315 accidents, 80, or 25.40%, were deaths.

The described state within the 'Households as employers and agriculture activities' sector is caused by insufficient care by the state, the low level of education, the use of child labour from an early age, as well as the low standard of living, due to which households are forced to do different types of work. This is a matter of serious concern and the problem grows further considering that many occupational diseases and workplace accidents remain unregistered.

Therefore, the main lifesaving rules of our country must always be designed to reduce risks during critical activities, provide an added measure of protection and strengthen our existing occupational safety and health management system.

## REFERENCES

- Amponsah-Tawiah, K. (2013). Occupational Health and Safety and Sustainable Development in Ghana. *International Journal of Business Administration*, 4, 74-78. <http://dx.doi.org/10.5430/ijba.v4n2p74>
- Amponsah-Tawiah, K. and Mensah, J., (2016). Occupational health and safety and organizational commitment: Evidence from the Ghanaian mining industry. *Safety and health at work*, 7(3), pp. 225-230. doi: 10.1016/j.shaw.2016.01.002.

Anttonen, H. and Pääkkönen, R., (2010) Risk assessment in Finland: theory and practice. *Safety and health at work*, 1(1), pp. 1-10.

Directive 89/391/EEC (1989) - OSH "Framework Directive" (Council Directive 89/391/EEC of 12 June 1989 on the introduction of measures to encourage improvements in the safety and health of workers at work, OJ L183, 29.06.1989). Available at: <https://osha.europa.eu/en/legislation/directives/the-osh-framework-directive/1> [Accessed 07 July 2022].

European Commission. European Statistics on Accidents at Work (ESAW) (2013). Summary methodology. Luxembourg: Publications Office of the European Union, 59 pp. Theme: Population and social conditions Collection: Methodologies & working papers ISBN 978-92-79-28419-9 ISSN 1977-0375 doi:10.2785/40882 Cat. No KS-RA-12-102-EN-N.

Eurostat (2019) Accidents at work statistics. *Eurostat Statistics Explained*, Data extracted in January. Available at: [https://ec.europa.eu/eurostat/statistics-explained/index.php?title=Accidents\\_at\\_work\\_statistics](https://ec.europa.eu/eurostat/statistics-explained/index.php?title=Accidents_at_work_statistics) [Accessed 07 July 2022].

Law on Occupational Safety and Health (Official Gazette of the Republic of Macedonia, No.92/2007).

Lutovska M., Mijakovski V., Idriži B. (2017) Occupational safety and health at work as a part of sustainable development agenda. *South East European Journal of Sustainable Development*; Vol1; ISSN: 2545-4463, eISSN: 2545-4471; <https://seejsd.unt.edu.mk/wp-content/uploads/2018/04/SEEJSD-Vol-1-2018-finale11309-1.pdf>

MOSHA (2010-2021) Annual Report for fatalities, injuries and accidents at work for 2010-2021. Macedonian Occupational Safety and Health Association.

Taubitz, M. (2010) How Safety Fits with Sustainability. *Occupational Health & Safety Magazine's*, 01. September. Available at: <https://ohsonline.com/articles/2010/09/01/how-safety-fits-with-sustainability.aspx> [Accessed 21 May 2022].

World Health Organization (WHO) (1995) *Global strategy on occupational health for all: The way to health at work*. Geneva.

## BIOGRAPHY of the first author

**Monika Lutovska** was born in Bitola, North Macedonia, in 1971. She received a diploma in mechanical engineering and a Ph.D. degree in mechanical engineering from the University of Bitola, Faculty of Technical Sciences in Bitola.



Her main areas of research include occupational safety and health, environmental protection engineering, energy supply, etc.

She is currently employed as an associate professor at the Faculty of Technical Sciences in Skopje, Mother Teresa University in Skopje.



ADEEB SIDANI<sup>1</sup>  
JOÃO POÇAS MARTINS<sup>2</sup>  
ALFREDO SOEIRO<sup>3</sup>

<sup>1,2</sup>CONSTRUCT – GEQUALTEC,  
Faculty of Engineering (FEUP),  
University of Porto, Portugal

<sup>3</sup>Faculty of Engineering (FEUP),  
University of Porto, Portugal

<sup>1</sup>adeeb.sidani@hotmail.com

<sup>2</sup>jppm@fe.up.pt

<sup>3</sup>avsoeiro@fe.up.pt

## INVESTIGATING BIM-BASED CONSTRUCTION SAFETY EDUCATION TECHNIQUES

**Abstract:** Building construction projects are dynamic and hazardous, incorporating complex and dangerous tasks. As a result, health and safety of workers in the construction sector are at risk. Improving the worker's perception of dangerous situations can reduce site accidents and reduce injuries and fatalities. However, safety training and education in the construction industry continue to rely on traditional methods.

This study investigates the safety training approaches developed using BIM to improve construction workers' safety skills and perceptions. Based on a systematic review related to BIM-based health and safety systems, articles in the field of safety training and education were acquired. Findings suggest that innovative teaching tools such as Augmented and Virtual Reality (AR/VR) linked to BIM may be more effective than traditional teaching methods. However, BIM-based safety education is still in its initial phase, and future development requires a more extensive and enhanced training module using interactive, BIM-based, 4D visualisation systems to support construction safety education and training.

**Key words:** Construction Education; Safety Training; Building Information Modelling (BIM); Construction Health and Safety.

## INTRODUCTION

In the AECO (Architectural, Engineering, Construction, and Operation) sector, relentless health and safety measures to prevent construction accidents are being implemented. However, construction workers have the most severe accident and death rates among other sectors (Ahn et al., 2020).

In 2019, 199,200 injuries were recorded in the AECO sector by the Occupational Safety and Health Administration (OSHA). The AECO sector is responsible for 9.5 fatalities per hundred thousand full-time workers. Likewise, one in five worker fatalities were in the AECO sector (Labor, 2019). According to the U.S. Labour statistics, the major causes of accidents and injuries are struck-by-objects, falls, stuck-in, and electrocution. These causes were responsible in 2019 for 58.6% of deaths of AECO workers (Labor, 2019).

A recent theory for accident causes and prevention has been based on five accident causation factors that are important to eliminate in accident prevention (Wang, 2018). These factors are Environment and heredity, Management, Personal factors, Job factors, Unsafe actions, and conditions. Thus, staff members must undergo special and elaborate safety education and training to avoid dangerous behaviours prior to on-site construction activities. In addition, the construction site should constantly be monitored and inspected to prevent accidents (Wang, 2018). However, according to OSHA, construction safety procedures are not

communicated properly. In particular, workers who have limited worksite experience, especially new workers and interns, are more likely to get injured than experience workers (Mason et al., 2017).

Traditional safety measures rely on manual monitoring and inspection. Thus, these methods are error prone (Eleftheriadis et al., 2017). Traditional accident prevention methods are still being executed, highlighting the urgent need to transform AECO safety management into a digitalised one (Zhou et al., 2015). Building Information Modelling (BIM) is shown to be a promising tool aiding in the automation of the safety management of the AECO sector (Eleftheriadis et al., 2017). Many studies investigate the possibilities of integrating (BIM) into safety education and training (Clevenger et al., 2015). The visualisation may enhance the worker's and the students' ability to conceptualise and understand construction concepts. BIM facilitates the visualisation to students and workers (Sidani, et al., 2021, a; Sidani, et al., 202, b). Alongside safety training and education, BIM tools are widely utilised in numerous safety areas: safety planning, safety monitoring, design for safety, safety inspection, and safety at the facility and management phase (Clevenger et al., 2015).

The main objective of this review is to analyse the existing proposals in the field of BIM-based construction safety education and training incorporating ICT technologies to evaluate the degree

of advancement of safety training and education in the construction industry. In addition, highlight the essential tools, techniques, and architectural frameworks to guide future BIM-based technology research and application on the use of safety training and education in the AECO industry.

### Methodology

This short review is based on a systematic review of BIM-based technologies for construction health and safety. The systematic review was done with the top multidisciplinary, electronic databases for scientific literature on construction and safety. The study will also follow the snowballing technique by looking through the articles' references to see relevant studies from any other database that were not collected during the search (Wohlin, 2014). Four keywords are considered for the search strategy: ("Building Information Modelling, Construction, Occupational Health and Safety") and considering synonyms of each keyword, such as BIM, work health and safety, accidents, and risks.

After screening the articles and following well-defined exclusion and inclusion criteria, for the exclusion criteria, conference, review, discussion, and unpublished articles were excluded. Similarly, studies not related to the AECO sector will be refused. Finally, 78 articles were considered for the review, among which only five articles were targeting the fields of safety training and education (Figure 1). Figure 1 mentions the number of fields each article targeted, considering that some articles mentioned more than one field totalling 114 fields targeted by the 78 articles. The authors decided to include a previously excluded article as a conference and not a journal article for this study. The article was the only excluded conference article targeting BIM-based health and safety training and education. The article was considered because it demonstrated relevant input for the current review and interesting results (Giusti & Bruttini, 2018).

The following sections will demonstrate the results of the collected articles, following a discussion of the main finding, limitations, and the most promising tools to be considered—finally, conclusions and future proposals.

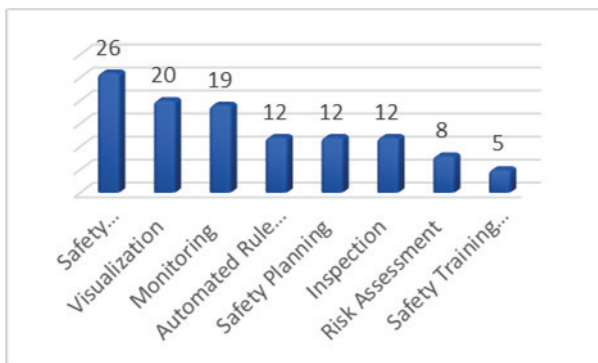


Figure 1. Number of mentions for Safety Fields

### Results

The results of the articles targeting training and education are classified into several categories, target groups, construction phases, targeted risks, assessment methods, BIM needs and dimensions, programs, and regulations and standards.

The main target groups are workers with five times (Afzal & Shafiq, 2021; Ahn et al., 2020; Giusti & Bruttini, 2018; Li et al., 2015; Park & Kim, 2013). Clevenger developed a prototype of an interactive safety training module targeting university students (Clevenger et al., 2015) and one mention for safety managers (Cheng et al., 2017) (Figure 2). Furthermore, all articles focused on the construction or preconstruction phase, as well half of the articles considered off-site training while the other half considered on-site training.

Concerning the safety risks implemented in the training sessions, two authors focused on general site risks (Giusti & Bruttini, 2018; Park & Kim, 2013). Afzal and Ahn targeted falls and struck by falling objects (Afzal & Shafiq, 2021; Ahn et al., 2020), one article aimed towards scaffolding safety measures (Clevenger et al., 2015), and one involved near miss and equipment maintenance (Li et al., 2015).

All authors represented an assessment method that varied from case studies, pilot tests, and surveys. Park presented a case study where a field safety accident occurred during a school construction project's reinforcement and formwork work. Safety managers tested and evaluated the educational sessions for a week (Park & Kim, 2013). Furthermore, Ahn conducted two training experiments developed and tested through testing trainees (Ahn et al., 2020). Afterwards, a survey was made directing safety managers, in which the workers evaluated the life-like quality of the training, active learning, and enjoyment that each of the training methods can promote. Finally, a case study was implemented at a high-rise building. Likewise, a case study and a survey targeting safety managers were made to assess the developed framework was done by Afzal (Afzal & Shafiq, 2021).

BIM was used by three authors as a geometric tool with non-geometric data such as schedule for time sequencing (4D) (Afzal & Shafiq, 2021; Giusti & Bruttini, 2018; Park & Kim, 2013), whereas the rest of the authors relied on BIM only for Geometric representations (3D).

The program used to develop the BIM models is Autodesk Revit. Revit was used by four out of the six authors, while the remaining two articles did not specify which BIM program was utilised. Most of the authors used a game engine to implement the training scenarios. Park used Microsoft XNA Game Studio to create an AR phone Application (Park & Kim, 2013). In comparison, Afzal implemented the BIM model into Unreal Engine, the VR Oculus Rift Headset (Afzal & Shafiq, 2021). Similarly, 3D Unity was used by (Li et al., 2015).



On the other hand, Ahn used Navisworks to create animations clarifying the accident hazards and types along with texts or narrations (Ahn et al., 2020). However, Clevenger adopted another method for training with Adobe Captivate, the safety training module was published to an HTML file, and an executable file was created to view using an Adobe flash player or an internet browser (Clevenger et al., 2015). Finally, Giusti implemented the training module in VR but did not mention any of the utilised software (Giusti & Bruttini, 2018).

Only two authors developed their training simulations based on official standards. Afzal based his training on the regulations for fall hazard prevention following Abu Dhabi Occupational Safety and Health Centre (OSHAD) requirements for safety planning (Afzal & Shafiq, 2021). At the same time, Clevenger based his work on the OSHA requirements for scaffolds (1926 subpart L – Scaffolds) (Clevenger et al., 2015).



Figure 2. Target Groups

## DISCUSSION AND CONCLUSION

The articles focus on training construction workers directly before or during the construction project. For instance, Park proposed an AR system where workers could visualise the continuous safety planning process, receive on-site education, and assist with site inspections. This shows that the workers received specific training and education associated with the construction project. The developed tool relies on accident cases, training material, and inspection checklists' databases (Park & Kim, 2013). On the other hand, VR utilisations were off-site and showed a general training simulation to improve the identification of on-site safety risks and increase the risk recognition capacity of workers. In addition, Afzal developed multilingual training scenarios for international projects in VR (Afzal & Shafiq, 2021; Giusti & Bruttini, 2018). On the other hand, Li applied a proactive Construction Management System (PCMS) designed for real-time warnings and analyses for safety training by automatically monitoring and recording workers' unsafe location-based behaviours. A link between safety training and facility management was expected, but no study targeted this issue.

VR and AR showed considerable potential to assist workers and students to visualise the risks on the

construction site. VR places the user in a virtual location, while AR adds layers or geometry to the actual surroundings.

The developed systems are essential for understanding the dynamics of construction sites and different construction tasks. The mentioned applications are advantageous for safety managers, who can adequately apply specific safety training and education. However, the findings show that BIM application for safety training and education has not been explored sufficiently. The studies highlighted several limitations, including the inability to identify many unsafe working conditions or risky worker behaviours, the fact that tracking workers violate privacy policies that cannot be implemented in various countries, the need for owners to be motivated to invest in implementing such tools, the necessity for consistent Level of development (LOD), and the fact that the process of developing simulations is time-consuming.

Thus, future research should focus on applying BIM-based tools, considering the barriers to implementing BIM-based safety training, such as a standardised architecture framework or plugins to reduce the model development and simulation time.

## REFERENCES

- Afzal, M., & Shafiq, M. T. (2021). Evaluating 4D BIM and VR for effective safety communication and training: A case study of multilingual construction job site crew. *Buildings*, 11(8). <https://doi.org/10.3390/buildings11080319>
- Ahn, S., Kim, T., Park, Y. J., & Kim, J. M. (2020). Improving Effectiveness of Safety Training at Construction Worksite Using 3D BIM Simulation. *Advances in Civil Engineering*, 2020. <https://doi.org/10.1155/2020/2473138>
- Cheng, M. Y., Chiu, K. C., Hsieh, Y. M., Yang, I. T., Chou, J. S., & Wu, Y. W. (2017). BIM integrated smart monitoring technique for building fire prevention and disaster relief. *Automation in Construction*, 84(August), 14–30. <https://doi.org/10.1016/j.autcon.2017.08.027>
- Clevenger, C., Del Puerto, C. L., & Glick, S. (2015). Interactive BIM-enabled safety training piloted in construction education. *Advances in Engineering Education*, 4(3).
- Eleftheriadis, S., Mumovic, D., & Greening, P. (2017). Life cycle energy efficiency in building structures: A review of current developments and future outlooks based on BIM capabilities. *Renewable and Sustainable Energy Reviews*, 67, 811–825. <https://doi.org/10.1016/j.rser.2016.09.028>
- Giusti, V. G. T., & Bruttini, P. C. T. S. A. (2018). A Project Framework to Introduce Virtual Reality in Construction Health and Safety. In *bo New Frontiers of Construction Management Workshop*, 09(November), 166–175.
- Labor, U. S. D. of. (2019). National Census Of Fatal Occupational Injuries In 2019. In Bureau of Labor Statistics (Issue 202). <https://www.bls.gov/news.release/pdf/cfoi.pdf>
- Li, H., Lu, M., Chan, G., & Skitmore, M. (2015). Proactive training system for safe and efficient precast installation. *Automation in Construction*, 49(PA), 163–174. <https://doi.org/10.1016/j.autcon.2014.10.010>
- Mason, K. L., Retzer, K. D., Hill, R., & Lincoln, J. M. (2017). Occupational Fatalities Resulting from Falls in the

Oil and Gas Extraction Industry, United States, 2005–2014. *MMWR. Morbidity and Mortality Weekly Report*, 66(16), 417–421. <https://doi.org/10.15585/mmwr.mm6616a2>

Park, C. S., & Kim, H. J. (2013). A framework for construction safety management and visualisation system. *Automation in Construction*, 33, 95–103. <https://doi.org/10.1016/j.autcon.2012.09.012>

Sidani, A., Dinis, F. M., Sanhudo, L., Duarte, J., Santos Baptista, J., Poças Martins, J., & Soeiro, A. (2021). Recent Tools and Techniques of BIM-Based Virtual Reality: A Systematic Review. *Archives of Computational Methods in Engineering*, 28(2), 449–462. <https://doi.org/10.1007/s11831-019-09386-0>

Sidani, A., Matoseiro Dinis, F., Duarte, J., Sanhudo, L., Calvetti, D., Santos Baptista, J., Poças Martins, J., & Soeiro, A. (2021). Recent tools and techniques of BIM-Based Augmented Reality: A systematic review. In *Journal of Building Engineering* (Vol. 42, p. 102500). Elsevier BV. <https://doi.org/10.1016/j.jobbe.2021.102500>

Wang, Y. (2018). The Theory of Zero Incident Safety Management. *Journal of Civil, Construction and Environmental Engineering*, 3(3), 83. <https://doi.org/10.11648/j.jccee.20180303.15>

Wohlin, C. (2014). Guidelines for snowballing in systematic literature studies and a replication in software engineering.

ACM International Conference Proceeding Series. <https://doi.org/10.1145/2601248.2601268>

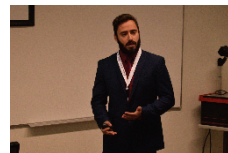
Zhou, Z., Goh, Y. M., & Li, Q. (2015). Overview and analysis of safety management studies in the construction industry. *Safety Science*, 72, 337–350. <https://doi.org/10.1016/j.ssci.2014.10.006>

## **BIOGRAPHY of the first author**

**Adeeb Sidani** was born in Beirut, Lebanon, in 1991.

He received a diploma in Architectural Engineering and is currently a Ph.D. candidate in Construction Health and Safety at the University of Porto.

His main areas of research include Virtual Reality, Augmented Reality, Building Information Modelling, and Automated Rule checking.



BOJANA ZORAJA<sup>1</sup>  
MIODRAG ŽIVANČEV<sup>2</sup>  
BOJANA TOT<sup>3</sup>

<sup>1,2,3</sup> University of Novi Sad, Faculty of Technical Sciences, Department of Environmental Engineering and Occupational Safety

<sup>1</sup>bojanazoraja@uns.ac.rs

## OCCUPATIONAL SAFETY RISK ASSESSMENT MODEL IN THE WASTE MANAGEMENT SECTOR

**Abstract:** In the Republic of Serbia landfilling remains the dominant way of managing waste; moreover, it has been used increasingly in previous years in contrast to the practice in the EU. It has been found that workers in the waste management sector have higher mortality rates than firefighters or police officers and experience high rates of injuries and illnesses as a result of their work. To perform the risk assessment of several proposed jobs in the waste management sector, a specific model of risk assessment was developed. Based on the performed risk assessment for the given positions, it was determined that there are some jobs with particularly increased risk. The risk assessment was performed as a basis for the development of a curriculum for professional training of workers in the waste management sector. Special attention during the development of training is directed to the identified jobs with increased risk.

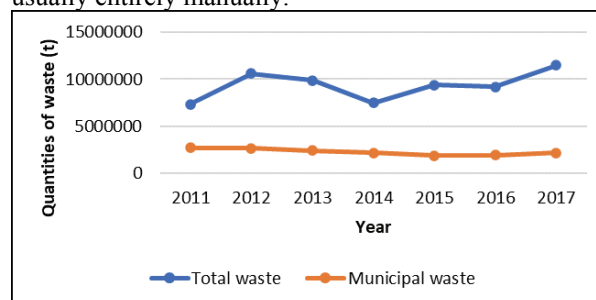
**Key words:** waste management, risk assessment

### INTRODUCTION

The total amount of waste generated in the European Union (EU) has been growing in recent years. There have been some shifts in waste production between different sectors and types of waste, but absolute levels of waste generation are generally increasing (Laitinen & Rantio, 2022). Between 2010 and 2016, the total amount of waste generated in the EU (excluding mineral waste) increased by 5.1%. Waste production in the water and waste sector increased by 38%. This waste includes secondary waste, and the more complex the waste management system, such as recycling and incineration, the greater the amount of secondary waste (Waste Generation, 2022).

The Republic of Serbia (RS) follows trends in waste generation, as shown in Figure 1. According to the National Bureau of Statistics, in 2017 the total waste production in RS amounted to 48.9 million tonnes, which is 3.3% more than the previous year. Information from companies obligated to submit data to the Environmental Protection Agency (SEPA) on the amount of waste generated provides significantly different numbers of total quantities, but there is an apparent growth trend. According to these data, in 2017, 11.5 million tonnes of waste were generated in RS, of which 2.15 million was municipal waste. A year earlier, 9.2 million tonnes of waste were generated, of which 1.9 million tonnes were municipal (Waste management in the Republic of Serbia from 2011 to 2017, 2018, Waste generated and treated 2014, 2015, Generated and treated waste 2015, 2016, Generated and treated waste 2017, 2018).

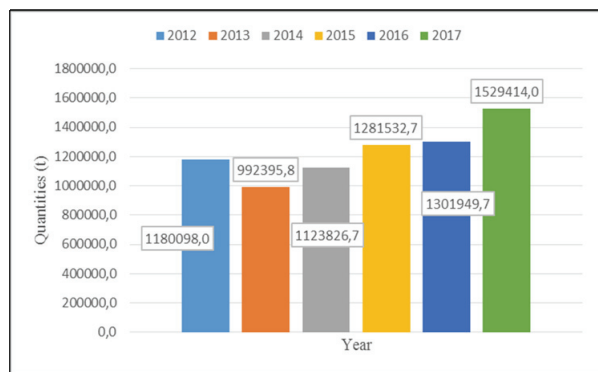
In RS, landfilling remains the dominant way of managing waste; there has been an increase in previous years in contrast to the overall practice in the EU. Figure 2 shows the growth trend of landfills in RS (Waste management in the Republic of Serbia from 2011 to 2017, 2018) The waste separation system is usually located at the landfill site and as the amount of disposed waste increases, so does the amount of waste that needs to be processed on the separation lines, usually entirely manually.



**Figure 1.** Trend of total and municipal solid waste generation for the 2010-2017 period according to RS SEPA

In addition to sanitary, hygienic, and environmental significance, the waste management sector is also an important sector of employment. However, workers in the waste management sector face different risks. Many health risks and hazards are associated with waste management and work in the recycling industry, such as manual handling (waste handling), working position (standing), vibration (vehicle management, work equipment), chemicals, biological agents, work organization (pace of work, work control), and mechanical hazards (cuts). Also, numerous literature

sources point to various injuries that can occur in waste management processes. It is especially emphasized that open landfills (dumps) are the main source of bioaerosols that can negatively affect the respiratory health of waste management workers, cleaners, and other landfill workers (Bünger, 2007, Bunn, 2011, Poulsen, 1995).



**Figure 2.** Quantities of landfilled waste (hazardous and non-hazardous) for the 2012-2017 period

Like other countries in transition, solid waste management is a major environmental and occupational safety issue in Serbia. In developed countries, the situation is much better, but it can still be seen that the waste sector is a source of difficulties in terms of occupational safety and health.

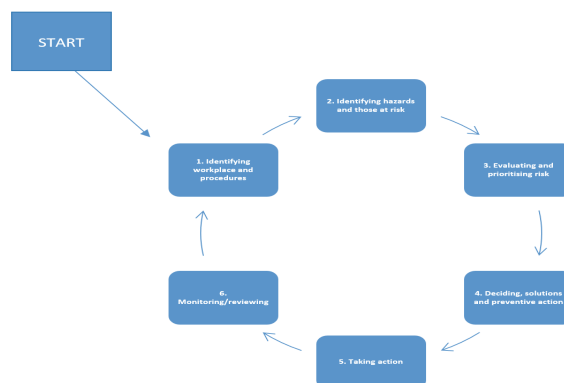
It has been found that workers in the waste management sector not only have higher mortality rates than firefighters or police officers, but also experience high rates of injuries and illnesses as a result of their work (Jamison, 2022). For example, it is pointed out that in Denmark, municipal solid waste workers have a 5.6 times higher risk of injuries at work and a 1.5 times higher risk of occupational diseases than the general workforce (Poulsen, 1995). It is predicted that the number of persons working on the disposal of municipal solid waste and exposed to occupational risks will increase, because of increased production of such waste and changes in general processing (for example, increased recycling rate) (Englehardt, 2015).

## OCCUPATIONAL SAFETY RISK ASSESSMENT AND MODEL DEVELOPMENT

Risks in the waste management sector are present and associated with various processes, such as street cleaning, waste collection, waste disposal, recycling, etc. In general, risks to the health and safety of workers at work may be related to:

- nature of the waste (chemical and biological risks);
- work process (noise, vibration, risk of falls, cuts, musculoskeletal disorders);
- work organization (traffic, different simultaneous activities, loads difficult to plan, etc.).

To perform the risk assessment of the proposed jobs, a model was developed based on the procedures shown in Figure 3 and the Ordinance on the manner and procedure of risk assessment in the workplace and in the work environment ("Official Gazette of RS", No. 72/2006, 84/2006 – corr. 30/2010 and 102/2015), while the Kinney risk assessment method was chosen, using the codes on hazards and harms (Rulebook on records in the field of safety and health at work "Official Gazette of RS", No. 62/2007 and 102/2015).



**Figure 3.** Workplace risk assessment scheme (European Agency for Safety and Health at Work, 2022)

The following jobs, for which occupational safety risk assessment needs to be developed, have been identified in the waste management process: container handling worker, special vehicle driver, driver of 5m<sup>3</sup> ordinary dumpster and construction waste dumpster vehicle, street cleaning worker, driver of cleaning vehicle, construction waste collection worker, worker in charge of street cleaning, construction waste collection worker, bulldozer driver, compactor driver, and manual waste sorting worker. The analysis was performed according to the steps shown below.

### • Step 1 – Job Identification

For job descriptions, conditions and insight into work procedures, processes, and relationships, it is necessary to use job systematization, previous documents containing job descriptions and risk assessments, and documents containing technological process descriptions, and to interview workers at their workplace and their immediate superiors, as well as other employees who may be in the area. The more thorough and accurate the data, the better the value of the assessment results will be.

### • Step 2 – Hazard Identification

The data on present hazards and harms are obtained based on the following documents/actions: documents with a description of the technological procedure; recording of the organization of work (photographing the workplace and the environment, interviewing the workers and their superiors, as well as co-workers involved in the work process); analyses of accredited laboratories on working environment conditions

(microclimate (temperature, air flow rate, and relative humidity), chemical hazards (gases, vapours, fumes, and dust), physical hazards (noise, vibration, and harmful radiation), lighting, and biological hazards); inspection and testing of equipment and machinery; inspection of installations (electric, gas, lightning); instructions and documentation on work equipment maintenance; documents on additional training for safety at work (professional/additional training for safe work when handling equipment for work in internal transport, etc.), records, etc.

- Step 3 – Evaluation, assessment, and prioritization of risk

One of the many recognized methods is chosen and applied to the identified hazards. Risk analysis and calculation determine whether a particular job involves increased risk or not.

- Step 4 – Decisions on solutions and determination of preventive measures

Based on the obtained results and the identified risks, preventive and corrective measures for each job are defined in the previous step. Current regulations in the field of preventive measures for safe and healthy work prescribed by the competent Ministry and other regulations, standards, good practices, etc. are used. These measures include technical solutions, working methods, supervision, training, and occupational safety services. Hierarchy of safety preventive interventions comprises the following aspects:

1. Replacement of hazardous process or material
2. Technical measures
3. Organizational measures
4. Personal protective equipment (PPE)
5. Personal behaviour.

- Step 5 – Implementation of preventive activities

In accordance with the identified risks, it is necessary to define corrective measures. In general, the following principles should be met:

- Monitoring noise and vibration levels, air quality, lighting, and other working environment conditions in the laboratory; regularly testing and maintaining work and installation equipment;
- Providing training on safety at work and raising awareness (referrals, instructions, vacations);
- Paying special attention to the training of new staff;
- Implementing standard operating procedures (supervisors trained in specific risk situations, shutdowns, and hazards – specially trained workers);
- Having the incident response plan prepared;

- Keeping the workplace clean should be promoted;
- Promoting waste sorting at the source (for example, in households, hospitals, and commercial facilities). Also, promoting waste quality control in plants with a separation line (especially manual);
- Preparing and displaying lists of hazards in different phases of work in a visible place;
- Setting up EHS signalling;
- Restricting movement in high-risk areas;
- Designing equipment and working machines in accordance with the workers;
- Equipping the plant with fire extinguishing equipment. Lighter and portable firefighting equipment should be provided.

- Step 6 – Monitoring of implemented measures and audits where necessary

In practice, the application of the defined preventive measures is controlled. This step is carried out by the companies themselves and the competent inspectorate.

## RESULTS

The activities were implemented within the global project "Migration for Development" implemented in Serbia, where a developed model for risk assessment was implemented on the one public company in Novi Sad. The results of the conducted risk assessment for the selected jobs in the company are given in Table 1. Based on the specific conditions for these jobs in the waste management system, the results show that some jobs involve increased risk. Such jobs are marked red in the table. The basis for the defining increased risk for these jobs are working conditions which include:

-For container handling workers: hazards of participating in traffic, hard physical work, biological harms, physical harm (noise and vibration) and adverse climatic influences such as increased and decreased temperature (outdoor work).

-For street cleaning workers: hazards of participating in traffic, adverse climatic influences such as increased and decreased temperature (outdoor work).

-For construction waste collection workers: hazards of participating in traffic, biological harms, physical harm (noise and vibration), and adverse climatic influences such as increased and decreased temperature (outdoor work).

-For bulldozer driver and compactor drivers: danger of overturning, jamming, machine fall through the landfill body, machine failure, biological harms (exposure to infectious disease carriers and zoonoses), exposure to unpleasant odours (feeling of nausea and other discomforts).



-For manual waste sorting workers: mechanical injuries and insufficient safety due to sharp and dangerous waste parts (such as punctures on a used syringe), biological harms (exposure to infectious disease carriers and zoonoses), exposure to unpleasant odours (feeling of nausea and other discomforts), dust, insects, rodents (bites and various allergic reactions and diseases).

These findings correspond with the conducted studies among employees in composting facilities in Germany (Bünger, 2007) and municipal solid waste workers in Florida (Englehardt, 2015). This suggests the additional need for monitoring the health status of such workers, as well as the need for additional training for safety at work. In practice, the conditions of these jobs are actively changing due to the job characteristics in specific working environments, so it is necessary to conduct more frequent audits of occupational risk assessments. In one company, the same job will involve increased risk, while in another there is a possibility that the same job will not entail increased risk due to the applied measures or different conditions in the work environment.

**Table 1.** Overview of jobs for which a risk assessment was performed

Job	Normal risk	Increased risk
Container handling worker	-	
Special vehicle driver		-
Driver of 5m <sup>3</sup> ordinary dumpster vehicle and construction waste dumpster vehicle		-
Street cleaning worker	-	
Driver of cleaning vehicle		-
Construction waste collection worker	-	
Bulldozer driver	-	
Compactor driver	-	
Manual waste sorting worker	-	

## CONCLUSION

The available data on workers working with municipal waste in Serbia are very limited. In such a high-risk industry as municipal waste management, promoting the health and safety of workers, as well as mitigating risks and dangers, have to take high priority. For example, unlike workers who handle hazardous waste (e.g. asbestos), there is no national safety standard for workers who handle municipal waste (Decree on preventive measures for safe and healthy work during

asbestos exposure, 2015, Instruction on workplaces where employees are exposed to dust from asbestos or materials containing asbestos occasionally and of low intensity, 2016, Ordinance on the treatment of asbestos-containing waste, 2010) The existence of significant risks suggests the need for further research in this area, as well as the need to improve current regulations. Local public health institutions usually regulate health issues and companies often have their own health and safety programs. However, the effects of such programs can vary significantly in practice.

A model for the defined jobs was developed and explained by following the six steps shown in Figure 3. The results of the assessed risk are shown in Table 1. It was determined that some jobs involve increased risk. Therefore, it is necessary to pay additional attention to such jobs in terms of health and safety at work. This risk assessment was performed as a basis for the development of a curriculum for professional training of workers in the waste management sector. An example of a risk assessment will be included in future research.

## REFERENCES

- (2015). *Ordinance on the manner and procedure of risk assessment in the workplace and in the work environment*, Official Gazette of RS", No. 72/2006, 84/2006 – corr., 30/2010 and 102/2015(2015). *Rulebook on recors in the field of safety and health at work*, Official Gazette of RS, No. 62/2007 and 102/2015
- (2015). *Waste generated and treated 2014*, Republic Statistical Office, Belgrade
- (2016). *Generated and treated waste 2015*, Republic Bureau of Statistics, Belgrade
- (2018). *Generated and treated waste 2017*, Republic Bureau of Statistics, Belgrade
- (2018). *Waste management in the Republic of Serbia from 2011 to 2017*, Republic of Serbia, Ministry of Environmental Protection, Environmental Protection Agency, Belgrade
- Bunn, T. L., Slavova, S., Tang, M. (2011). 'Injuries among solid waste collectors in the private versus public sectors', *Waste Management & Research* 29 (10), pp. 1043–1052
- Bünger, J., Schapper-Scheele, B., Hilgers, R., Hallier, E. (2007). 'A 5-year follow-up study on respiratory disorders and lung function in workers exposed to organic dust from composting plants', *Int Arch Occup Environ health* 80, pp. 306-312
- Decree on preventive measures for safe and healthy work during asbestos exposure* NN 108/15
- Englehardt, H. A., Fleming, L. Bean, J. (2015). 'Occupational health and safety amongst municipal solid waste workers in Florida', *Safety Science*, pp. 55–65
- European Agency for Safety and Health at Work, (2022). [online], available at: <http://osha.europa.eu/en/topics/riskassessment>
- Instruction on workplaces where employees are exposed to dust from asbestos or materials containing asbestos occasionally and of low intensity* N.N. 42/16
- Jamison, J. ((2022). *Risks and Hazards for Recycling and Waste Workers in the Bay Area*, *Labor Occupational Health*



Program, University of California, Berkley, [online], available at: [http://lohp.org/wp-content/uploads/2013/09/EBASE .pdf](http://lohp.org/wp-content/uploads/2013/09/EBASE.pdf)

Laitinen, S., Rantio T. (2022) *Exposure to hazardous substances in the waste management sector, Finnish Institute of Occupational Health, Finland*, [online], available at: [https://oshwiki.eu/wiki/Exposure\\_to\\_dangerous\\_substances\\_in\\_the\\_waste\\_management\\_sector](https://oshwiki.eu/wiki/Exposure_to_dangerous_substances_in_the_waste_management_sector)

*Ordinance on the treatment of asbestos-containing waste*, N.N. 75/2010

Poulsen, O. M. et al. (1995). 'Sorting and recycling of domestic waste. Review of occupational health problems and their possible causes', *The Science of the Total Environment* 168, pp. 33-56

*Waste generation*. (2022), [online], available at: <https://www.eea.europa.eu/airs/2018/resource-efficiency-and-low-carbon-economy/waste-generation>

## ACKNOWLEDGEMENTS

The activities were implemented within the global program "Migration for Development" (MFD) implemented in Serbia by Deutsche Gesellschaft für Internationale Zusammenarbeit GmbH (GIZ). The program is part of a broader initiative "Back to New Opportunities" by the German Federal Ministry for Economic Cooperation and Development.

## BIOGRAPHY of the first author

**Bojana Zoraja** was born in Novi Sad, Serbia, in 1983. She received a diploma in environmental engineering and a Ph.D. degree in occupational safety from the University of Novi Sad, Faculty of Technical Sciences.



Her main areas of research include asbestos, occupational safety, etc. She is currently working as a Teaching Assistant at the Faculty of Technical Sciences in Novi Sad, University of Novi Sad.



**BOJANA TOT<sup>1</sup>**  
**GORAN VUJIC<sup>2</sup>**  
**DRAGAN ADAMOVIĆ<sup>3</sup>**

<sup>1,2,3</sup> University of Novi Sad,  
Faculty of Technical Sciences,  
Department of Environmental  
Engineering and Occupational Safety

<sup>1</sup>bojanatot@uns.ac.rs

<sup>2</sup>goranvujic@uns.ac.rs

<sup>3</sup>draganadamovic@uns.ac.rs

## TRAINING MODULE FOR WASTE MANAGEMENT WORKERS

**Abstract:** Supporting an effective regional waste management system that operates in accordance with the circular economy principles is one of the main research goals in Serbia. Through the study activities in Novi Sad, the lead municipality in the South Bačka waste management region, two techno-economic analyses have been conducted. The objectives of this study were to (1) develop a curriculum for professional training of workers in waste management jobs; (2) conduct qualification (pilot) training based on the developed curriculum required for workers to obtain employment in the Public Utility Company (PUC) and in waste management; and (3) initiate the process of curriculum certification. The analyses focused on the need for increasing technical and human resources in the PUC as well as on additional and new activities of the PUC in maintaining the public hygiene system within the city of Novi Sad. In the absence of a framework for the training of waste management workers in Serbia, a detailed curriculum for a professional training programme for waste management workers based on the specific job requirements was developed.

**Key words:** waste management, workers, training, curriculum.

## INTRODUCTION

The goal of an occupational safety and health programme is to foster a safe and healthy occupational environment. Occupational safety and health refer to policies and procedures that companies adopt for their general and specific jobs to ensure the health and safety (H&S) of employees in their workplaces (WHO, 2012). These policies and procedures include hazard identification and control in accordance with state standards, as well as continuous training and education of employees. According to the World Health Organization (WHO), occupational health covers all aspects of occupational health and safety and is strongly focused on primary hazard prevention (WHO, 2018). Waste management can be considered a service sector that is highly vulnerable to occupational hazards, health problems, and workplace injuries. Accordingly, the International Labour Organization (ILO) identifies safety education and training for employees who work in solid waste collection and treatment as one of the main priorities in this sector (Benjamin, 2008). Some studies (Englehardt, 1999) indicate that the time lost because of injuries and health problems related to the waste management workplace is 7 times longer than the time lost in other workplaces (Hämäläinen, 2017). Waste collectors generally have little or no social, economic, or legal protection, and often include women and children. They are continually exposed to hazardous substances, materials, and pathogens, as well as to new, complex, and hazardous waste flows, such as

electronic waste (ILO, 2012). Another example is the shipbreaking industry, which also faces major occupational safety and health (OSH) hazards that need to be addressed promptly (ILO, 2012). A common practice in countries of South-East Europe (SEE) is for low-skilled workers to work in the waste management sector. In Serbia and other SEE countries, the responsibility for providing H&S training is defined by specific laws, and such training is mandatory for all employees in a company. However, this legal mandate is not fully implemented, so it is necessary to consider the legal basis for all types of employee groups. Companies usually implement procedures that need to be improved and updated to fit any new knowledge. Unfortunately, professional specialization is at a very low level. Since there are no secondary schools that provide education for solid waste handling, there is a need to prepare a well-defined professional training curriculum for specific employee groups. Implementation of good waste management concepts has to be covered by educational plans.

There is also a need for a systematic approach and a wide range of educational methods (Verbeek, 1993). All waste management workers need to possess a certain level of education in waste management. Well-defined H&S educational programmes, emphasizing safety precautions when handling hazardous materials and fire protection, are a good way to reduce injuries and improve the efficiency of the employees (Verbeek, 1993, Midtgard, 1997). Companies that provide

education and training according to the Professional Development for Operational Staff and Health & Safety will reap direct benefits (Ettala, 1989, Englehardt, 1999, Dement, 1999). This study is intended to help the Municipality of Novi Sad to establish or enhance a comprehensive occupational safety and health management system so as to eliminate safety and health risks for the benefit of the workers. This will improve the PUC performance in their service provision due to increased productivity and reduced absenteeism from work. The study should also provide an understanding of safety and health risk management for solid waste handling, which can assist the PUC in determining effective interventions to reduce or eliminate the risks. This includes reviewing the existing safety and health measures and the current waste collection practices, and then considering interventions such as elimination of hazards and administrative controls such as employee induction, on-the-job training, pre-employment medical examinations, introduction of vaccination programmes, as well as training for the use of personal protective clothing.

The purpose of this paper is to provide a curriculum for a professional training programme for waste management workers: Professional Development for Operational Staff Including Health & Safety in the waste management sector. The paper focuses on the education of waste management workers.

## MATERIALS AND METHODS

Before professional specialization training, the examination of the main work parameter of the employees – efficiency concerning the time and quality of task completion – was performed. It was also relevant to review the records of past injuries, because they help guide the training and professional specialization.

The risk assessment was performed as a basis for the development of a curriculum for professional training of workers for waste management jobs. To perform the risk assessment of proposed jobs, it was first necessary to develop a model based on the procedures and the *Rulebook on the manner and procedure of risk assessment in the workplace and the work environment*. After that, the waste management jobs for which occupational safety risk assessment needs to be performed were identified. A model for these jobs was developed and explained in six steps. The curriculum and the training activities were then defined based on job performance.

The examination of the main working parameter of the employees – efficiency concerning the time and quality of task completion – was performed. A detailed training plan and programme was provided: Professional Development for Operational Staff Including Health & Safety in the waste management sector. Based on the examination, the curriculum and the training activities were defined. A detailed curriculum for a professional training programme for waste management workers based on specific job

requirements was developed by experienced waste management experts and trainers, in close cooperation and coordination with the designated persons from the PUC during a series of consultations with waste management professionals and relevant authorities. The experts prepared a training programme with a curriculum that includes the number of classes, training agenda, and the accompanying teaching materials.

The developed curriculum for professional training of workers for waste management jobs with accompanying training/teaching materials complies with specific needs of the PUC and includes eight modules:

1. Education of a bulldozer driver;
2. Education of compactor drivers;
3. Education of special vehicle drivers;
4. Education of a driver of a five cubic meter ordinary dumpster vehicle and a construction waste dumpster vehicle;
5. Education of drivers for hygiene standards of waste management vehicles;
6. Education of workers for waste container handling;
7. Education of construction waste collection workers;
8. Education of manual waste sorting workers.

### I. Training of trainers

Education was conducted through three-day oral lectures as well as discussions with trainers, providing them with instructions. All the experts presented the curriculum in detail and explained how activities would be implemented and what the main focus of the activities would be. They also shared with the participants many practical examples that could be useful for professional training of waste management workers. Training for trainers consists of a general and specific part. In the curriculum, a separate part was provided for basic fire protection training, because it has been shown that fire is a frequent cause of injuries in the waste sector.

Based on the job systematization and job description, the experts defined the safety equipment compliant with the specific job position. In the second part of the training, the experts presented the potential challenges expected in the education of waste management workers. The experts then acquainted the participants with the waste management system as well as the basic goals of waste management. This was followed by a presentation of good practice of performing job tasks as efficiently as possible, which includes professional training, proper and efficient work with working equipment, and processes of work and professional training in order to incorporate individual jobs into a narrower and broader work system. The experts then introduced the terms and obligations of the occupational safety and health sector to all the participants. They were acquainted with the basic legislation in the field of occupational safety and

health. The experts presented to the participants the risks of fires and explosions in the workplace, the basic procedures in the event of a fire, proper use of equipment for initial fire suppression, as well as accountability for non-compliance with the prescribed and mandatory fire protection measures.

## II. Training of waste management workers

The programme of the training courses was defined for every job description with the focus on specific operational skills. The trainings were provided according to the number of employees in each group and they included theoretical and practical parts.

The theoretical part of the training was conducted through oral lectures as well as discussions with employees, giving them instructions for safe work. Theoretical training consists of a general and specific part. The specific part of the training programme covers the hazards and harms that may be experienced when performing specific tasks in the workplace using specific work equipment or hazardous materials and the measures taken to eliminate or reduce the identified risks. The theoretical competence test, which involved taking a written test, was administered after the employee training had been completed.

The practical training of employees for safe work involved informing them directly about the work process in their specific workplace and about safe use of the work equipment. Emphasis was placed on possible failures and risks if the equipment is not used in accordance with the safety instruction manual and the rules for proper use of personal protective equipment. The practical training of employees was organised during working hours at their workplace. It consisted of:

- Familiarisation with safe work conditions for in a specific workplace;
- Familiarisation with the proper method of using work equipment;
- Familiarisation with the types of potential risks and hazards present in the workplace;
- Familiarisation with the method of using personal protective equipment and collective protection, safe movement on the job, and the use of technical aids.

The experts shared many useful practical examples with waste management workers. Based on the job systematization and job description, the experts defined the safety equipment compliant with the specific job position.

Additionally, the waste management workers selected for training were included in the DIMAK info session organized in cooperation with PME / DIMAK Serbia, as an accompanying segment of the training.

## III. Plan for certification

A plan for the certification of the curriculum was developed by a team of experienced waste management and health and safety experts and trainers in close

cooperation and coordination with the designated persons from the PUC during a series of consultations with waste management professionals and relevant authorities.

## IV. Monitoring

Monitoring included the changes occurring on a monthly basis concerning any recorded injuries at work presented by position, as well as changes in the direct costs incurred due to injuries (material damage within the company, material damage caused to third parties, and sick leave, treatment and insurance of employees), as well as changes in the costs resulting from sanctions imposed by the competent authorities. This monitors every monthly change against the key indicators set up in the basic table. The results related to better working parameters should be in the form of quarterly reports, to ensure continuous monitoring of the progress. The number of worker injuries before and after the implementation of the program should be observed. These results will not be noticeable in a shorter period of time, as it takes several years. Direct benefits include:

- Less lost time due to injuries at work;
- Lower medical treatment costs;
- Lower financial compensation for health and safety issues.

## RESULTS AND DISCUSSION

The training of trainers was attended by 23 experts, who were divided into several smaller groups to prevent the spread of COVID-19. The training of trainers was successful – the team showed a good understanding of the material and the trainers were fully engaged, as they participated in every activity.

The experts taught trainers about all the procedures in case of accidents (first aid, road safety, use of protective equipment, etc.) and the basics of first aid in the event of an accident and other occurrences that may endanger multiple employees. Trainers were introduced to the personal protective equipment for each module, receiving instructions for their proper use, and to the conditions for safe and healthy work in a particular workplace. All the prospective trainers successfully completed the training of trainers.

Afterward, the trainers organized four trainings for more than 50 fifty waste workers. The complete training included all aspects of the theory and practical application of occupational health and safety measures. More than 90% of the workers successfully completed the training.

In the course of 2021, which was taken to be the reference year, there were no injuries at work at the public utility company and consequently also no costs incurred as a result of the effects of injuries at work. There were also no injuries at work over the six months period of monitoring the process. The complex training that embedded all aspects of the theory on and practical application of health and safety at work measures, including the provision of personal protection



equipment for all of the employees involved in the project, considerably contributed to raising the level of the quality of protection of employees and their safety in terms of potential injuries during their regular jobs in waste management. When we look at the process, in addition to the number of injuries at work and work-related ones, the key indicators covered by the monitoring included the financial savings achieved as a consequence of the potential direct costs incurred in relation to health and safety at work, as follows: costs of employee sick leaves due to injuries at work or work-related injuries, costs of additional engagement of labor that the public utility company would have to provide, as well as costs incurred on the grounds of the legally prescribed sanctions in the Republic of Serbia. In this context, based on the calculation of the total costs of lost time due to injury for 3 employees only and the costs of additional engagement of labor to ensure the unimpeded performance of the regular operations and owing to the process introduced, it may be concluded that the financial savings of the employer total 2,255.26 EUR every month, and based on the minimum average earnings in the Republic of Serbia in 2021. Based on the calculation of the total cost of lost time due to injury for three employees was determined. Over the six months of process monitoring analyzed, therefore, the total savings for the employer on these two key cost items amount to 13,531.53 EUR for three employees and calculated against the minimum average earnings. In addition, pursuant to item 8 of Article 69 of the Law on Health and Safety at Work of the Republic of Serbia, the employer is sanctioned with a fine of 6,780 up to 8,475 EUR if they fail to equip the employee with the skills and equipment required for healthy and safe work. The costs of the minimum prescribed fine for 50 employees that underwent the training would on these grounds amount to 339,000 EUR, which is an indicator of direct savings for the employer.

## CONCLUSION

In Serbia, there are no secondary schools specialising in waste management education. Companies that provide H&S training will therefore reap the benefits of the improved and safer working conditions, which will consequently lead to better motivation of the employees. The benefits are directly visible through the reduced number of injuries, which decreases the costs of medical treatments and financial compensation for health and safety issues. H&S education and training has improved the company management even further with the introduction of legal acts concerning H&S. This means that the company avoided the financial penalties prescribed by the law for using untrained workers. Another benefit for the company is the increased efficiency of employees because, in addition to H&S training, professional specialization was also organised, which further improved the employee training.

## REFERENCES

- Benjamin, A. O. (2008). *Fundamental principles of occupational health and safety*, Second edition, International Labour Office – Geneva: ILO, ISBN 978-92-2-120454-1
- Dement, J.M. (1999). ‘Lipscomb Workers’ compensation experience of North Carolina residential construction workers’, *Applied Occupational and Environmental Hygiene*, Vol. 44, pp. 97-106.
- Englehardt, J., Fleming, E., Lora, A.B., Huren, A., Nicolette, J., Rogers, J., Melissa D. (1999). *Solid Waste Management Health and Safety Risks: Epidemiology and Assessment to Support Risk Reduction*
- Englehardt, J.D., Bean, J.A., Fleming, L.E., Dantis, M. (1999). *Solid Waste Management Health and Safety Risks Epidemiology and Assessment to Support Risk Reduction Report to Florida Center for Solid and Hazardous Waste Management*, University of Miami, FL, USA
- Ettala, M., Rahkonen, P., Peltola, H. (1989) ‘Work safety in waste collection and transport’, *Waste Management and Research Vol. 7*, pp. 241-248.
- Hämäläinen, P., Takala, J., Boon Kiat, J. (2017). ‘Global Estimates of Occupational Accidents and Work-related Illnesses’, *XXI World Congress on Safety and Health at Work, Singapore, Workplace Safety and Health Institute*
- International Labour Organization (ILO) (2012). *Promoting safety and health in a green economy*, Geneva
- Midtgard, U., Poulsen, O.M. (1997). ‘Occupational safety and health in waste collection and recycling, the CORE research programme’, *Annals of Agriculture and Environmental Medicine*, Vol. 4, pp. 21-26.
- Verbeek, J.H.A.M., Hushof, C.T.J., Van Dijk, F.J.H. (1993). ‘Evaluation of an occupational health care programme. negative results, positive results or a failure’, *Journal of Occupational Medicine*, 43 Vol. 1, 1993, pp. S34-S37.
- World Health Organization (WHO) (2012). *Health in the green economy – occupational health*, Geneva
- World Health Organization (WHO) (2018). *Preventing disease through a healthier and safe workplace*, Geneva

## ACKNOWLEDGEMENTS

This paper is part of the Project Training for waste management workers. The project activities were implemented within the Programme ‘Migration for Development’ in Serbia, with the support by the Deutsche Gesellschaft für Internationale Zusammenarbeit (GIZ) GmbH.

## BIOGRAPHY

**Bojana Tot** was born in Zrenjanin, Serbia, in 1985. She received a master’s degree in environmental engineering and a Ph.D. degree in environmental engineering from the University of Novi Sad, Faculty of Technical Sciences.





UGLJEŠA JOVANOVIĆ<sup>1</sup>  
DEJAN KRSTIĆ<sup>2</sup>  
DARKO ZIGAR<sup>3</sup>  
JELENA MALENOVIĆ-NIKOLIĆ<sup>4</sup>

## IMPACT OF MOBILE PHONE PITCH AND ROLL ANGLES ON SAR DISTRIBUTION IN A HUMAN HEAD

<sup>1,2,3,4</sup>University of Niš,  
Faculty of Occupational Safety in Niš

<sup>1</sup>ugljesa.jovanovic@znrfak.ni.ac.rs

<sup>2</sup>dejan.krstic@znrfak.ni.ac.rs

<sup>3</sup>darko.zigar@znrfak.ni.ac.rs

<sup>4</sup>jelena.malenovic@znrfak.ni.ac.rs

**Abstract:** This paper presents a numerical analysis of a Specific Absorption Rate (SAR) of an adult person's head while absorbing electromagnetic (EM) radiation emitted from a mobile phone. Simulations employ a model of a contemporary smartphone with a single antenna and an anatomically accurate model of a human head. Seven positions of the mobile phone were evaluated to infer the smartphone's optimal position, which resulted in minimal SAR distribution inside the brain. The mobile phone position, concerning the head, was changed by tilting the mobile phone's pitch and roll angles. The frequency of EM radiation in all simulations was 900 MHz. Paper presents the obtained numerical results.

**Key words:** SAR, electromagnetic radiation, human head, smartphone, pitch angle, roll angle, simulation.

### INTRODUCTION

When held in a standard talk position during a phone call, a mobile phone emits electromagnetic (EM) radiation into a human head. Since International Agency for Research on Cancer classified mobile phone EM radiation in Group 2B, as possibly carcinogenic to humans, the public concern regarding this issue has increased (Baan, 2011). Consequently, numerous studies evaluate and try to understand the impact of mobile phone EM radiation on human health.

Specific Absorption Rate (SAR) represents a safety measure to protect the public from the harmful effects of EM radiation. SAR refers to the rate of energy absorbed by a human body or only a tissue when exposed to EM radiation. Its common representation is a value averaged over 1 g or 10 g of tissue mass. There are two guidelines to limit the exposure for mobile phone users (ICNIRP, 2009; IEEE, 2019).

In the USA, the maximal permissible SAR value is 1.6 W/kg over 1 g of tissue (FEC, 2016), while in Europe, the maximal permissible value is 2 W/kg averaged over 10 g of tissue (IEC, 2005).

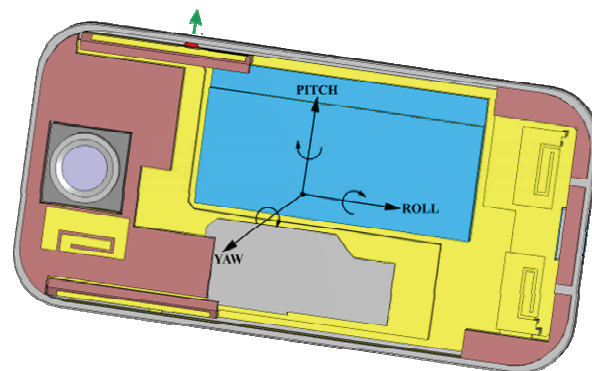
Many reports note that the central nervous system is particularly vulnerable to EM radiation emitted by a mobile phone (Kim et al., 2019; Okechukwu, 2020). Therefore, the presented research analyses SAR<sub>1g</sub> levels on the brain surface. Regarding that, the main goal of the presented research was to find a suitable position to minimize EM radiation absorption without compromising the standard talk position.

### NUMERICAL METHOD AND MODELS

Human exposure to EM radiation for scientific purposes is limited and complex due to ethical

considerations, which makes numerical simulations a much more convenient solution. This research presents numerical simulations conducted using the CST Studio based on the FIT (Finite Integration Theory) method of solving Maxwell's equations (Clemens et al., 2001).

The source of EM radiation was a contemporary smartphone. This mobile phone is available from CST Studio, and Figure 1 shows its photo. It has a 2G, 3G, and 4G GSM coverage, but the presented research employs only a single 2G/3G antenna. The excitation port of this antenna is marked with red colour in Figure 1, while the green arrow illustrates the direction of its radiation pattern. In addition to antennas, the mobile phone also contains a large LCD, battery, PCBs, camera, and a plastic case. Figure 1 also shows a smartphone's pitch, roll, and yaw axes.



**Figure 1.** Photo of the smartphone; diagram of pitch, roll and yaw axes

Due to the radiation pattern of the 2G/3G antenna, the brain will inevitably absorb a part of emitted EM radiation when the mobile phone is leaned on the head. Other antennas were excluded from simulations only

because they do not emit EM radiation in the brain, or absorption of their EM radiation cannot be minimized.

Simulation results will be accurate if the model of a human head is anatomically accurate and contains a sufficient number of well-detailed tissues. With this in mind, the simulations were conducted on the AustinMan 2.6 voxel-based human model, explicitly developed for physics simulations by the National Library of Medicine’s Visible Human Project data set (Spitzer et al., 1996). AustinMan is an anatomically accurate model of an adult man 187 cm tall and 113 kg heavy (Massey et al., 2016). AustinMan represents the version of the Hugo model, available from the CST Voxel Family, but with significantly more tissues, which has been used in numerous similar studies (Barchanski et al. 2005; Barchanski et al. 2006). The resolution of AustinMan is  $1 \times 1 \times 1 \text{ mm}^3$ .

Biological tissues have dielectric properties necessary to calculate SAR distribution, which are frequency depended and obtainable from the IT’IS foundation (Hassgall et al., 2022). Table 1 contains the head tissues’ list and their dielectric properties at 900 MHz.

**Table 1.** List of tissues with their dielectric properties

Tissue	Permittivity	Electric Conductivity
Blood Vessel	44.775	0.696
Bone Cortical	12.453	0.143
Bone Marrow	5.504	0.040
Brain Grey Matter	52.725	0.942
Brain White Matter	38.886	0.590
Cartilage	42.652	0.782
Cerebellum	49.444	1.262
Cerebro Spinal Fluid	68.638	2.412
Dura	44.426	0.961
Eye Cornea	55.235	1.394
Eye Lens	46.572	0.793
Eye Sclera	55.270	1.166
Eye Vitreous Humor	68.901	1.636
Fat	5.461	0.051
Lymph	59.683	1.038
Medulla Oblongata	49.444	1.262
Midbrain	49.444	1.262
Mucous Membrane	55.031	0.942
Muscle	55.031	0.942
Nerve	32.530	0.574
Pons	49.444	1.262
Salivary Gland	75.986	0.815
Skin	41.405	0.866
Spinal Cord	32.530	0.574
Tendon	45.825	0.718
Tongue	55.270	0.936
Tooth	12.453	0.143
Trachea	42.007	0.771

Simulations where the mobile phone is placed in a standard talk position concerning the human head were analysed in the presented research.

## SIMULATION RESULTS

Simulations were performed for six smartphone positions concerning the head in which the pitch and roll angles were altered. In contrast, the yaw angle remained constant at  $30^\circ$  because this is the yaw angle of most common talk positions.

The radiation frequency was set to 900 MHz, while the antenna output power was 1 W (Beard et al., 2006). SAR<sub>1g</sub> calculations were according to IEEE C95.3 standard using the post-processing operation.

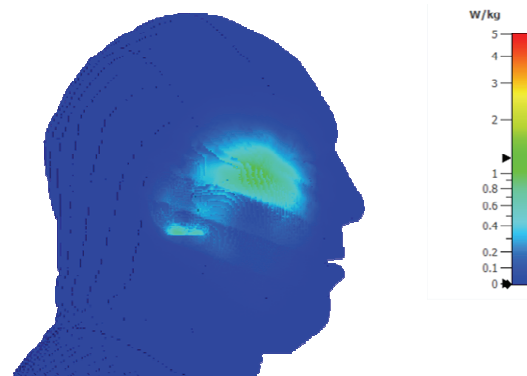
### First position

In the first simulation, pitch and roll angles were set to  $90^\circ$  concerning the head, as shown in Figure 2. Although it is unlikely for a user to hold a smartphone in such perfect alignment, this position serves as a reference point for remaining evaluated positions.



**Figure 2.** Photo of the first simulated position

Figure 3 shows SAR<sub>1g</sub> distribution on the head surface for this simulation in which the smartphone is missing from the photo to have a clear view of SAR<sub>1g</sub> distribution.



**Figure 3.** SAR<sub>1g</sub> distribution on the head surface of the first simulated position

Figure 3 shows that most SAR<sub>1g</sub> is concentrated on the upper part of the cheek and cheekbone, which is expected due to the radiation pattern of the 2G/3G antenna. The maximal value of SAR<sub>1g</sub> in this simulation was 1.205 W/kg, meaning that the SAR<sub>1g</sub> is clearly under the maximal value (IEC, 2005).

Figure 4 shows SAR<sub>1g</sub> distribution on the brain surface with the remaining tissues and smartphone removed from the photo to have a clear view of SAR<sub>1g</sub> distribution. Figure 4 shows that almost the entire right

temporal lobe absorbs EM radiation and the maximal recorded SAR<sub>1g</sub> value was 0.195 W/kg.

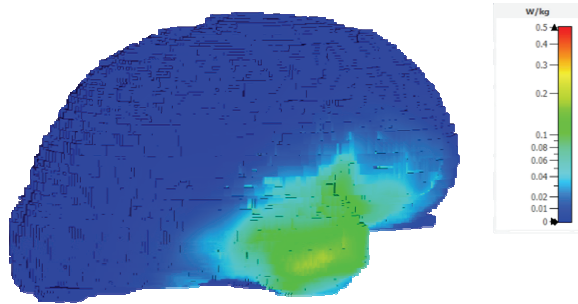


Figure 4. SAR<sub>1g</sub> distribution on the brain surface of the first simulated position

### Second position

In this simulation, the smartphone was leaned on the ear by turning the pitch angle to 85° concerning the head while the roll angle remained unchanged, which is a more common talk position than the first position. Figure 5 shows the alignment between the head and smartphone for this talk position.



Figure 5. Photo of the second simulated position

Figure 6 shows the SAR<sub>1g</sub> distribution on the head surface in the case of this simulation.

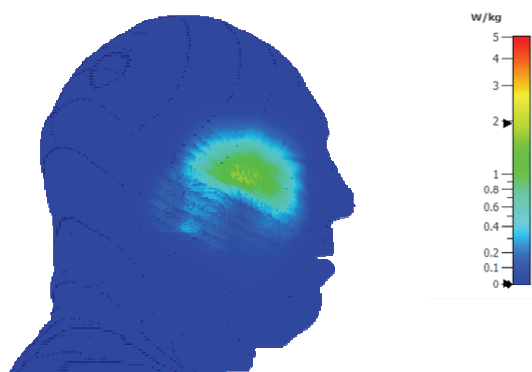


Figure 6. SAR<sub>1g</sub> distribution on the head surface of the second simulated position

A minor pitch angle change significantly increases the SAR<sub>1g</sub> value on the head surface by more than 60% since the maximal value is now 1.883 W/kg. Although SAR<sub>1g</sub> is still within the permissible limits, it can easily exceed the safe zone if the smartphone is pinched even more against the ear.

Figure 7 shows the SAR<sub>1g</sub> distribution on the surface of the brain. It is visible that a slightly more significant

area of the temporal lobe absorbs EM radiation compared to the previous simulated position, and the maximal SAR<sub>1g</sub> level on the brain surface increases to 0.269 W/kg.

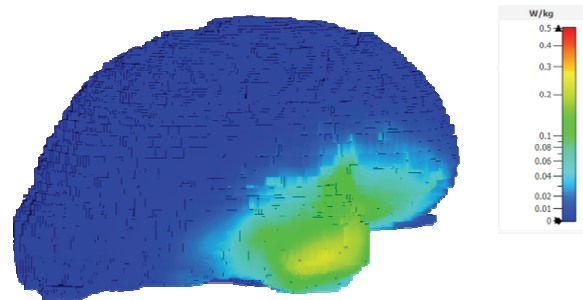


Figure 7. SAR<sub>1g</sub> distribution on the brain surface of the second simulated position

### Third position

In this simulation, the smartphone lays down on the cheekbone curve while leaning on the ear. In other words, the smartphone has an 85° pitch angle and 83° roll angle concerning the head, which is the most common talk position among mobile phone users. Figure 8 shows the photo of this talk position.



Figure 8. Photo of the third simulated position

Figure 9 shows this simulation's SAR<sub>1g</sub> distribution on the head surface.

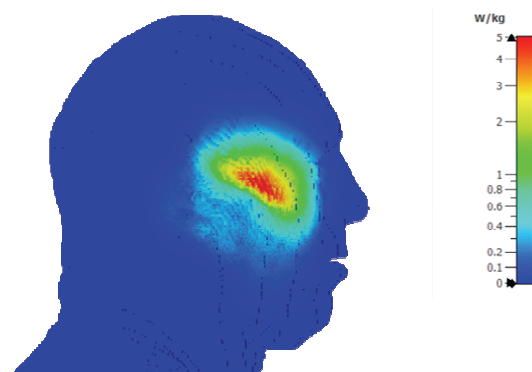
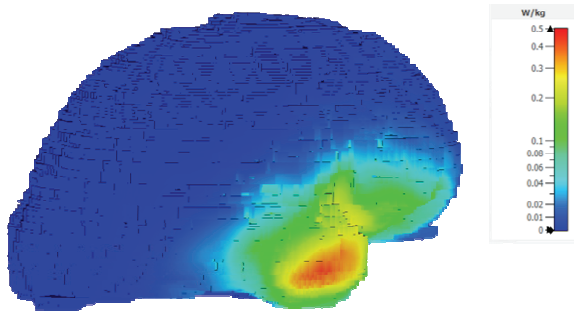


Figure 9. SAR<sub>1g</sub> distribution on the head surface of the third simulated position

Figure 9 shows a noticeable increase in SAR<sub>1g</sub> value. SAR<sub>1g</sub> exceeds the maximal permissible level roughly by 2.8 times since the maximal recorded value in this simulation was 5.614 W/kg.

Figure 10 shows the SAR<sub>1g</sub> distribution on the brain's surface.





**Figure 10.**  $SAR_{1g}$  distribution on the brain surface of the third simulated position

Figure 10 shows that even the broader area of the temporal lobe absorbs emitted EM radiation. A higher  $SAR_{1g}$  rate is also clearly noticeable. The maximal recorded  $SAR_{1g}$  value was 0.442 W/kg, which is more than two times greater than the first simulated position.

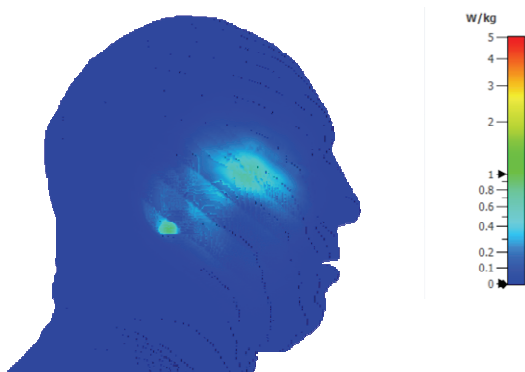
#### Fourth position

In this simulation, the smartphone was placed in the first position and then tilted  $5^\circ$  away from the head along the pitch axis while the roll angle remained unchanged at  $90^\circ$ . In other words, the pitch angle was  $95^\circ$ , as shown in Figure 11. The idea is to move the radiation pattern away from the head, thus minimizing SAR value and protecting the brain while, at the same time, not compromising the standard talk position.



**Figure 11.** Photo of the fourth simulated position

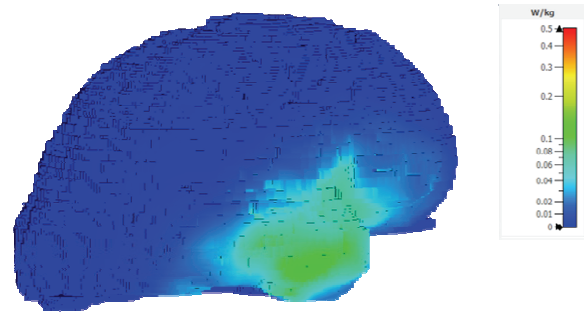
Figure 12 shows this simulation's  $SAR_{1g}$  distribution on the head surface.



**Figure 12.**  $SAR_{1g}$  distribution on the head surface of the fourth simulated position

Figure 12 shows that  $SAR_{1g}$  value drops, and the maximal  $SAR_{1g}$  value was 0.683 W/kg,

Figure 13 shows the  $SAR_{1g}$  distribution on the surface of the brain. Based on the distribution, it is evident that the smaller temporal lobe area absorbs EM radiation, and  $SAR_{1g}$  values are much less compared to the previous simulations. The maximal recorded  $SAR_{1g}$  value was 0.126 W/kg.



**Figure 13.**  $SAR_{1g}$  distribution on the brain surface of the fourth simulated position

The maximal  $SAR_{1g}$  values confirm that the SAR level will drop by tilting the smartphone along the pitch axis to oppose the head, even by a slight angle such as  $5^\circ$ .

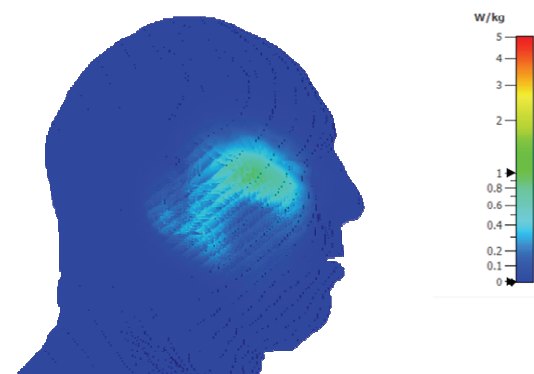
#### Fifth position

In this simulation, the smartphone lays down on the cheekbone curve while being tilted  $5^\circ$  away from the ear along the pitch axes, i.e., it has a  $95^\circ$  pitch angle and  $83^\circ$  roll angle concerning the head. Figure 14 shows a photo of this evaluated talk position.



**Figure 14.** Photo of the fifth simulated position

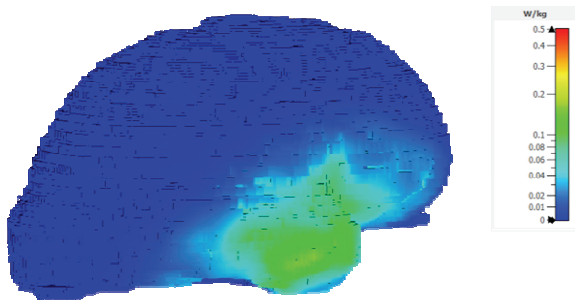
Figure 15 shows  $SAR_{1g}$  distribution on the head surface for this simulation.



**Figure 15.**  $SAR_{1g}$  distribution on the head surface of the fifth simulated position

SAR<sub>1g</sub> is in the safe zone, yet higher than in the case of the previous simulation because the new maximal SAR<sub>1g</sub> value was 0.977 W/kg.

Figure 16 shows the SAR<sub>1g</sub> distribution on the surface of the brain.



**Figure 16.** SAR<sub>1g</sub> distribution on the brain surface of the fifth simulated position

The maximal recorded SAR<sub>1g</sub> level on the brain surface was 0.168 W/kg, one-third more significant than in the case of the previous simulation. The increase is because a much wider area of the smartphone is close to the head in contrast to the previous simulation, where only the edge of the smartphone was close to the head.

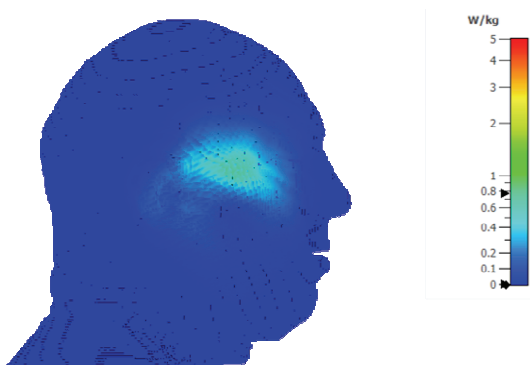
### Sixth position

In this simulation, the smartphone was positioned 10° away from the cheek along the roll axis while lying on the ear. In other words, it has an 85° pitch angle and a 100° roll angle concerning the head. Figure 17 shows the photo of this talk position.



**Figure 17.** Photo of the sixth simulated position

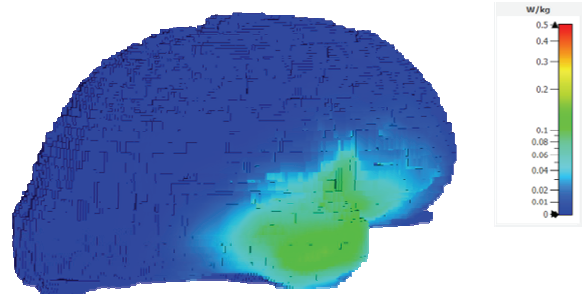
Figure 18 shows this simulation's SAR<sub>1g</sub> distribution on the head surface.



**Figure 18.** SAR<sub>1g</sub> distribution on the head surface of the sixth simulated position

The maximal recorded SAR<sub>1g</sub> value was 0.755 W/kg, which is slightly higher than in the case of the fourth simulated position yet less compared to other positions.

Figure 19 shows SAR<sub>1g</sub> distribution on the brain's surface and is very similar to the SAR<sub>1g</sub> distribution of the previous simulated position, with the only difference being slightly lower values. That being said, the maximal recorded SAR<sub>1g</sub> value was 0.151 W/kg.



**Figure 19.** SAR<sub>1g</sub> distribution on the brain surface of the sixth simulated position

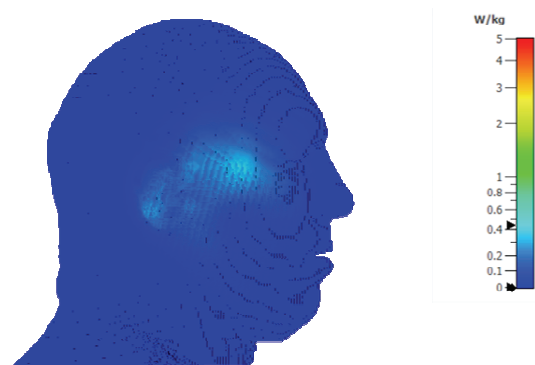
### Seventh position

In this simulation, the smartphone was positioned 10° away from the cheek along the roll axis while being tilted 5° away from the ear along the pitch axes, i.e., it has a 95° pitch angle and 100° roll angle concerning the head as shown in Figure 20.



**Figure 20.** Photo of the seventh simulated position

Figure 21 shows this simulation's SAR<sub>1g</sub> distribution on the head surface.



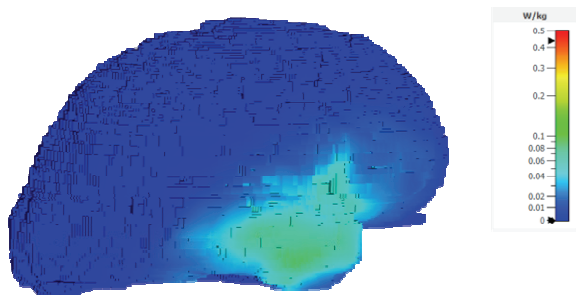
**Figure 21.** SAR<sub>1g</sub> distribution on the head surface of the seventh simulated position

The maximal recorded SAR<sub>1g</sub> value was 0.421 W/kg, which is by far the lowest recorded value compared to



all previous simulations, lower even than SAR<sub>1g</sub> absorbed by the brain in the case of the third position.

Figure 22 shows the SAR<sub>1g</sub> distribution on the surface of the brain. Compared to all previous simulations, it is evident that the smallest area of the temporal lobe absorbs EM radiation, and the maximal recorded SAR<sub>1g</sub> value was the lowest being just 0.091 W/kg.



**Figure 22.** SAR<sub>1g</sub> distribution on the brain surface of the seventh simulated position

## CONCLUSION

This research presents SAR<sub>1g</sub> distribution inside of an adult man's brain, exposed to the EM radiation from the smartphone with a single 2G/3G antenna. Seven talk positions with different pitch and roll angles were simulated on an anatomically accurate voxel-based human model at 900 MHz frequency to minimize the SAR<sub>1g</sub> level on the brain's surface.

Although wrapping tissues absorb most of the EM radiation, its significant part still manages to penetrate the brain. It is reflected as a significant SAR<sub>1g</sub> value on the brain surface, particularly in the most commonly used talk position.

By increasing the pitch angle of the mobile, the SAR<sub>1g</sub> level begins to drop, but the best results are obtainable while, at the same time, the roll angle is increased.

## REFERENCES

Baan, R. (2011). 'Carcinogenicity of radiofrequency electromagnetic fields,' *The Lancet Oncology*, 12(7), pp. 624-626.

ICNIRP (2009). 'Guidelines for limiting exposure to time-varying electric, magnetic, and electromagnetic fields (up to 300 GHz),' *Health Physics*, 97(3), pp. 257-259.

IEEE (2019). *IEEE standard for safety levels with respect to human exposure to radio frequency electromagnetic fields, 3 kHz to 300 GHz*.

FEC (2016). *Specific absorption rate SAR for cellular telephones*.

IEC (2005). *Human exposure to radio frequency fields from hand-held and body-mounted wireless communication devices - human models, instrumentation, and procedures - part 1: Procedure to determine the specific absorption rate (SAR) for hand-held devices used in close proximity to the ear (frequency range of 300 MHz to 3 GHz)*.

Kim, J.H., Lee, J.K., Kim, H.G., Kim, K.B., Kim, H.R. (2019). 'Possible effects of radiofrequency electromagnetic field exposure on central nerve system,' *Biomolecules & Therapeutics*, 27(3), pp. 265-275.

Okechukwu, C.E. (2020). 'Effects of radiofrequency electromagnetic field exposure on neurophysiology,' *Advances in Human Biology*, 10(1), pp. 6-10.

Clemens, M., Weiland, T. (2001). 'Discrete electromagnetism with the finite integration technique,' *Progress in Electromagnetics Research*, 32, pp. 65-87.

Spitzer, V., Ackerman, M.J., Scherzinger, A.L., Whitlock, D. (1996). 'The visible human male: a technical report,' *Journal of the American Medical Informatics Association: JAMIA*, 3, pp. 118-30.

Massey, J.W. and Yilmaz, A.E. (2016). 'AustinMan and AustinWoman: "High-fidelity, anatomical voxel models developed from the VHP color images,' *38<sup>th</sup> Annual International Conference of the IEEE Engineering in Medicine and Biology Society (IEEE EMBC)*, pp. 3346-3349.

Barchanski, A., De Gersem, H., Gjonaj, E., Weiland, T. (2005). 'Impact of the displacement current on low-frequency electromagnetic fields computed using high-resolution anatomy models,' *Physics in Medicine in Biology*, 50(19), pp. 243-249.

Barchanski, A., Steiner, T., De Gersem, H., Clemens, M., Weiland, T. (2006). 'Local grid refinement for low-frequency current computations in 3-D human anatomy models,' *IEEE Transactions on Magnetics*, 42(4), pp. 1371-1374.

Hasgall, P.A., Di Gennaro, F., Baumgartner, C., Neufeld, E., Lloyd, B., Gosselin, M.C., Payne, D., Klingensböck, A., Kuster, N. (2022). 'IT'IS Database for thermal and electromagnetic parameters of biological tissues,' Version 4.1, *IT'IS Foundation*.

Beard, B.B., Kainz, W., Onishi, T., Iyama, T., Watanabe, S., Fujiwara, O., Wang, J., Bit-Babik, G., Faraone, A., Wiart, J., Christ, A. (2006). 'Comparisons of computed mobile phone induced SAR in the SAM phantom to that in anatomically correct models of the human head,' *IEEE Transactions on Electromagnetic Compatibility*, 48(2), pp. 397-407.

## ACKNOWLEDGEMENTS

The presented research has been funded by the Ministry of Education, Science and Technological Development of the Republic of Serbia.

## BIOGRAPHY of the first author

**Uglješa Jovanović** received a MSc degree and a Ph.D. degree in electronics from the University of Niš, Faculty of Electronic Engineering in Niš. His main areas of research include electronics, embedded systems, application of electromagnetic radiation, etc.



He is currently a teaching assistant at University of Niš, Faculty of Occupational Safety in Niš.

NIKOLA ŠOBAT<sup>1</sup>  
MILE VAJKIĆ<sup>2</sup>  
BILJANA VRANJEŠ<sup>3</sup>  
LUTVO HAZNADAREVIĆ<sup>4</sup>

<sup>1</sup> Association of Occupational Safety and Health Engineers in the Republic of Srpska

<sup>2</sup> Mechanical school Prijedor

<sup>3</sup> University of Banja Luka, Faculty of Mechanical Engineering

<sup>4</sup> Logos Center High School, Mostar

<sup>1</sup>nikola.sobat73@gmail.com

<sup>2</sup>m.wajkic@gmail.com

<sup>3</sup>biljana.vranjes@mf.unibl.org

<sup>4</sup>hltuvo@yahoo.com

## ANALYSIS OF SAFETY MEASURES DURING THE REFILLING OF LIQUID HAZARDOUS SUBSTANCES - CASE STUDY

**Abstract:** Manipulation of liquid hazardous substances is a very complex and dangerous process. The complexity of the refilling hazardous substances process is reflected in the fact that two different technical systems are interconnected, and each of them has sufficient sources of hazard that significantly increase during the interaction. The characteristics of the hazardous substance being manipulated, as well as the fact that the systems are technically and structurally different and complicated, add to the complexity. The implementation of the process requires the application of specific measures and instructions when performing the procedures of loading, refilling, dispensing, or transporting liquid hazardous substances.

The aim of this paper is to determine risk factors when handling liquid hazardous substances (liquid petroleum fuels), taking into account the technical characteristics of vehicles, environmental technical characteristics, process performance characteristics, and the human factor which is one of the most important factors in the safety analysis. The magnitude of the influence of certain factors on the risk of accidents, specific phases of operations during the manipulation of liquid hazardous substances, and the prescribed preventive safety measures were considered. Preventive safety measures should be fully implemented in order to reduce the risks of accidents to an acceptable level.

Based on a critical analysis of the application of existing organizational and technical safety measures for the filling station considered in the paper, new measures have been proposed to reduce the occurrence of accidents. Therefore, this study can be used to improve safety measures for employees at filling stations. In a broader context, the study could be useful to economic entities and the entire community by preventing damage to material resources and threats to human lives.

**Key words:** liquid hazardous substances, refilling, accident, filling station, safety measures

## INTRODUCTION

Modern technical and technological systems, despite the obvious progress, still carry great risks of system elements' disruption of the working and living environment and the occurrence of occupational injuries, deaths, material damage, fires, explosions, and accidents. The process of storing and handling hazardous materials is complex process and very demanding in terms of safety.

Tank trucks are a source of danger both during transport and during the process of refilling (loading and unloading) liquid hazardous substances. Flammable liquids and gases are transported on various roads every day. The transport of such substances is becoming a topic of general interest, especially for

companies, organizations, and institutions that face this problem. When an unforeseen event occurs, questions of responsibility of the carrier, manufacturer, as well as other competent authorities are raised.

Based on global indicators, out of 242 tank accidents that occurred in industrial plants over the last 40 years, the results show that 74% of the accidents occurred in oil refineries and at oil terminals and warehouses. Fire and explosion accounted for 85% of the accidents. It happened that 80 accidents (33%) were caused by lightning and 72 (30%) were caused by human errors, including poor functioning and maintenance of the plant (Chang and Lin, 2006).

Most of these accidents could have been avoided if preventive and corrective measures based on

engineering studies, projects, recommendations, and instructions had been applied.

The transport of dangerous goods in international road transport is defined by national laws and regulations as well as international regulations according to the ADR agreement (European Agreement concerning the International Carriage of Dangerous Goods by Road). The ADR is an agreement that regulates the transport of dangerous goods and mandates all operators engaged in the transport of dangerous goods to adopt special safety measures to prevent risks during production (packaging), loading, transport, and unloading (Festić and Imamović, 2021). National legislation in this area regulates certain conditions under which dangerous goods are transported, actions related to them, as well as the packaging and vehicle requirements. The legislation includes the Law on Transport of Dangerous Goods of the Republic of Srpska and accompanying regulations, as well as the Law on the basics of road traffic safety in Bosnia and Herzegovina.

Regulations for transport, loading, unloading and handling of dangerous goods, packaging and marking, as well as other requirements related to vehicles and their equipment, crew, and necessary documentation in road traffic, are defined by the valid ADR agreement (ECE/TRANS/275, 2015).

Statistical analysis of traffic accidents shows that 80% of incidents and accidents during the transport of hazardous substances occur during their loading and unloading (refilling). Analyses show that in 90% of the cases the cause is a human factor (Best Practice Guidelines, 2013). Negative statistics of incident situations impose the need to increase safety during loading and unloading (refilling) of hazardous substances and establish guidelines, recommendations, and procedures for this process to help prevent or eliminate unsafe conditions and situations, promote best practices, and identify needs for the interaction of

all involved entities. At the operational level, in the transport of hazardous substances, risk identification and its minimization are mainly associated with route selection, vehicle characteristics, traffic network characteristics, and characteristics of participants in the transport process (training, compliance with existing regulations, psychophysical condition, etc.) (Krstić, 2017).

Filling stations are characteristic facilities for the supply of all types of liquid fuels and liquefied petroleum gas to motor vehicles, and storage and refilling (loading and unloading) of fuels and liquefied petroleum gas. Within the filling stations, there are also facilities for the accommodation of employees and other accompanying facilities. Filling stations are built following the provisions of regulations on landscaping and construction, regulations on public roads, regulations on conditions for the construction of filling stations along regional roads, main roads, and highways, and regulations on minimum technical requirements for business premises, equipment, devices, and required professional qualifications of employees (Pravilnik, 2012). Filling stations possess equipment according to the current legislation (Pravilnik, 2012). Persons employed at filling stations must be trained to properly handle devices at the station and fire extinguishers, must be familiar with other safety measures, and must have passed a professional exam for handling flammable liquids and gases (Pravilnik, 2012).

A refilling station (Figure 1) is a specially designated place equipped with devices permanently installed for the connection of transport tanks or tankers for the refilling of flammable liquids. The refilling of flammable liquids means the transfer (refilling) of flammable liquids from the tank to the transport tanks (tank trucks, tank wagons, tankers, etc.) and closed containers or vice versa.

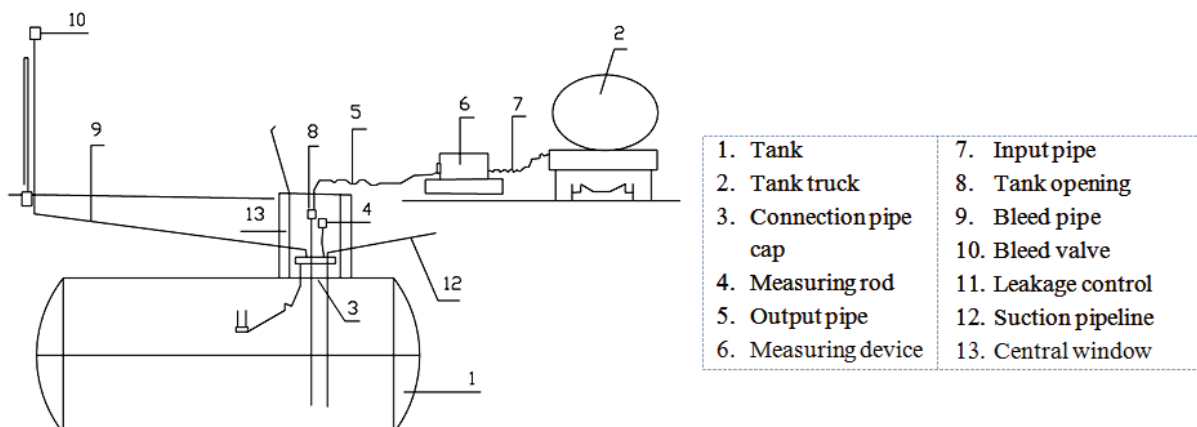
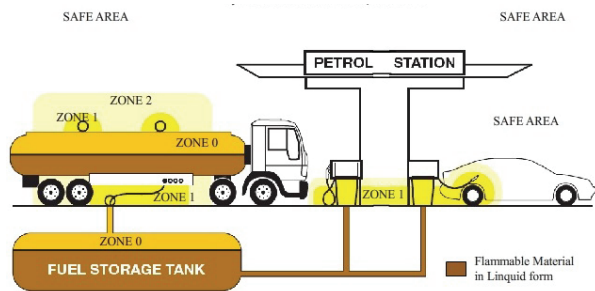


Figure 1. Scheme of fuel discharge by free fall from a tank truck (Poljak, 2013)

The charging and discharging process is risky due to the following reasons:

- charging and discharging: two systems are involved — vehicle and tank;
- charging and discharging: gases are released and danger zones are formed (Figure 2);
- charging requires appropriate equipment that must be located and used in hazardous areas.





**Figure 2.** Danger zones at the filling station (IECEx and ATEX Certification, 2022)

Refilling devices must be designed in such a way that eliminates the possibility of flammable liquids spillage or leakage during refilling outside the space where spilled liquids are collected. Discharged or in any way spilled flammable liquids can be drained only into the technological sewer, and their reception can be provided by special vessels from which the spilled liquid is drained into a space arranged for that purpose.

The refilling station should be equipped with manual and mobile fire extinguishers, a hydrant network, and stable cooling and extinguishing installations, depending on the assessment of the fire risk degree (Gašić, 2002).

Spills of petroleum products often lead to serious pollution of soil and watercourses (both surface and groundwater). Volatile organic compounds, which are an integral part of motor fuels, pose a serious environmental problem. Their release mainly takes place at filling stations during the refilling of fuel from tank trucks to underground storage tanks or during the delivery of fuel to the tanks of passenger and cargo vehicles. Their increased concentrations also lead to health problems.

Fuel discharges (gas or liquid phases) at the refilling point occur at the following places: vent pipe tank truck (if the tank truck has one), discharge valves, hose connections with the measuring device on the tank truck; inlet valves and vent pipes tank.

Harmful gases can also be released during breakdowns on filling station devices and installations, and not only during the process of handling hazardous substances.

The safety management system should identify the controlled risk and use it to effectively mitigate the occurred accident. Given the complexity of accident situations during transport and handling of hazardous substances, attention must be paid to:

1. The technical aspect:
  - properties of flammable liquid;
  - characteristics of devices and equipment;
  - vehicle characteristics;
  - characteristics of buildings and the surroundings.
2. The organizational aspect:
  - the human factor.
3. Actions and procedures during the handling of hazardous substances.

## CASE STUDY — ANALYSIS OF SAFETY MEASURES DURING THE REFILLING OF HAZARDOUS LIQUID SUBSTANCES

The data obtained in this research provide the necessary information to create databases about the company, responsible persons, potentially hazardous substances, vulnerabilities that may cause accidents and environmental pollution, and the professional competence of people involved in the storage and handling of hazardous substances, as well as collection of information regarding protection entities that manage the hazardous substances.

Accordingly, the process of refilling liquid petroleum fuels into the tank at "Nešković" JSC filling station, the Banja Luka branch, was observed and analyzed (Figure 3).



**Figure 3.** "Nešković" JSC filling station, Banja Luka

After the analysis of general safety measures, which included location and facility description, employees at the filling station, vehicles that transport liquid hazardous substances, process of liquid fuel discharge, liquid fuel refilling danger zones, and fire protection, it was determined that they meet all the legally prescribed conditions and requirements.

Additional security measure analyses at the filling station included the following:

### a) Testing of environmental pollution during the refilling of hazardous substances

The presence of harmful gas concentrations in the area of the filling station at three measuring points with the highest probability of emission of harmful gases during discharge was measured at:

- measuring point 1: tank truck hose connector from the underground tank pipe (Table 1);
- measuring point 2: tank truck hose connector with the outlet connection of the tank truck;
- measuring point 3: vents of underground reservoirs under the following external conditions: air temperature 24.2°C, relative humidity 42%, air flow rate 1 m/s,

atmospheric air pressure 1007.5 mbar, using the gas analyzer brand Gasmeter DX. Table 1 shows the permitted values, as well as the exposure, i.e. the time of exposure, to harmful gases. The exposure is 2.5 h, i.e. the time required to complete the discharge of the tank truck into the petrol station underground tank.

**Table 1.** Measured components of gases at measuring point 1 (Šobat, 2017)

Substance name	Permitted value		Meas. value	Exposure (continuous exposure)	yes/n <sup>o</sup>
	ppm	mg/m <sup>3</sup>			
Carbon dioxide CO <sub>2</sub>			<b>0.41</b>	2.5 <sup>h</sup>	-
Carbon monoxide CO	50	55	<b>0</b>	2.5 <sup>h</sup>	yes
Nitrogen suboxide N <sub>2</sub> O	-	-	<b>0</b>	2.5 <sup>h</sup>	-
Methane CH <sub>4</sub>			<b>0</b>	2.5 <sup>h</sup>	-
Nitrogen dioxide NO <sub>2</sub>	1	2	<b>0.36</b>	2.5 <sup>h</sup>	yes
Sulfur dioxide SO <sub>2</sub>	2	5	<b>0.04</b>	2.5 <sup>h</sup>	yes
Acetaldehyde C <sub>2</sub> H <sub>4</sub> O	50	90	<b>0.36</b>	2.5 <sup>h</sup>	yes
Acetone C <sub>3</sub> H <sub>6</sub> O	244	590	<b>0</b>	2.5 <sup>h</sup>	yes
Formaldehyde CH <sub>2</sub> O		1,5	<b>0</b>	2.5 <sup>h</sup>	-
Benzene C <sub>6</sub> H <sub>6</sub>	1	3	<b>0.36</b>	2.5 <sup>h</sup>	yes
Toluene C <sub>6</sub> H <sub>5</sub> -CH <sub>3</sub>	100	375	<b>0.09</b>	2.5 <sup>h</sup>	yes
m-Xylene C <sub>8</sub> H <sub>10</sub>	100	435	<b>0.53</b>	2.5 <sup>h</sup>	yes
Isopropanol C <sub>3</sub> H <sub>8</sub> O	400	980	<b>0</b>	2.5 <sup>h</sup>	yes
Ammonia NH <sub>3</sub>	25	18	<b>0.24</b>	2.5 <sup>h</sup>	yes
Acrolein C <sub>3</sub> H <sub>4</sub> O	0.1	0.25	<b>0</b>	2.5 <sup>h</sup>	yes
Ethyl acetate CH <sub>3</sub> -COO-CH <sub>2</sub> -CH <sub>3</sub>	400	1400	<b>0</b>	2.5 <sup>h</sup>	yes
Phenol C <sub>6</sub> H <sub>5</sub> OH	5	19	<b>0.4</b>	2.5 <sup>h</sup>	yes
Pyridine C <sub>5</sub> H <sub>5</sub> N	5	15	<b>0.32</b>	2.5 <sup>h</sup>	yes
Carbon disulfide CS <sub>2</sub>	10	30	<b>0</b>	2.5 <sup>h</sup>	yes
Trichlorethylene C <sub>2</sub> HCL <sub>3</sub>	25	130	<b>0</b>	2.5 <sup>h</sup>	yes
Styrene C <sub>8</sub> H <sub>8</sub>	50	215	<b>0</b>	2.5 <sup>h</sup>	yes
Hydrogen chloride HCL	5	7	<b>0</b>	2.5 <sup>h</sup>	yes
Methanol CH <sub>3</sub> OH	200	260	<b>0</b>	2.5 <sup>h</sup>	yes
Ethanol C <sub>2</sub> H <sub>6</sub> O	1000	1900	<b>0</b>	2.5 <sup>h</sup>	yes

All measured values of chemical compounds that appeared during the discharge of liquid petroleum fuel (24 of them) are within the permitted values concerning the exposure of 2.5 h. Therefore, they are not harmful to the workers during the mentioned procedure or to the environment.

**b) Examination of the human factor influence during the refilling of hazardous substances**

A survey method was used to examine the influence of the human factor on the occurrence of accidents during the transfer (refilling) of hazardous substances. The survey involved workers who participate in the process of liquid hazardous substance refilling and tank truck drivers. The total number of respondents is fifteen, and they are employed at various filling stations. The survey consists of twenty questions and is designed as a questionnaire to be filled out by the surveyed workers. The questions were factual and closed-ended, related to the tasks they perform on a daily basis. The offered answer is predictable (yes/I know, maybe/probably, and no/I don't know).

Based on the value analysis of the survey, the causes of accidents regarding the human factor are defined, and the following are emphasized:

- irresponsibility and insufficient work and technical discipline;
- non-compliance with safety measures at work;
- insufficient knowledge of the consequences of danger;
- insufficient training and qualification for safe work;
- negligence;
- inefficient supervision and monitoring of transport, storage, and handling of hazardous substances.

**c) Identification of critical points of the process and causes of the accident during storage and handling of hazardous substances**

Analysis of the safety conditions of facilities potentially dangerous to human health and safety and the environment, which include filling stations, involves determining:

- "critical points" in the system;
- causes of events relevant to risk assessment;
- event trees with potential consequences (Table 2).

The faults and relationships for each top event have been identified and a logical combination of incidents has been deduced that can trigger unwanted events (Fuentes-Bargues et al., 2017). In this way, each tree contains information about how the combination of certain faults leads to overall failure (Fuentes-Bargues et al., 2017).

Based on the measurements and analysis conducted on a specific example of the refilling of hazardous substances, specific critical places and situations were identified and corrective measures were proposed, as well as the following internal control measures to increase safety:

- adequate assessment of employees during hiring;
- workers should safely perform tasks and duties and follow regulations (revision of process refilling hazardous substance instructions to be as precise and clear as possible);



- installation of additional technical protection (protective ramp) when liquid hazardous substance refilling is in progress;
  - a more precise legal definition of the “Stop - tank truck connected” warning board appearance;
  - mandatory use of personal protective equipment (for outdoor work, personal cold-weather protective gear (clothing, footwear, gloves, hats);
  - installation of automatic switches on the tank for static electricity removal in order to eliminate the human factor influence;
  - installation of automatic fixed fire extinguishing systems (sprinklers) above the tank truck at the place where the fuel transfer (refilling) is performed
- to be engaged at the first hint of smoke or flame in case of an accident;
  - maintaining the hygiene of work premises and personal hygiene in order to prevent the possible intake of chemical substances into the body;
  - measurement of chemical substances at several measuring points in the workplace where the workers spend their time;
  - prohibition of smoking and food consumption in the workplace.

**Table 2.** Analysis of critical points, causes of dangerous events, and event trees with potential consequences for the refilling (transfer) of liquid hazardous substances (Šobat, 2017)

ANALYSIS OF THE PROCESS CRITICAL POINTS, FACILITIES AND/OR INSTALLATIONS		
Device and installations for storage and refilling of hazardous substances		
The process critical point	Cause of dangerous events important for risk assessment	Event tree with potential consequences
<p>Considering the function of the hazardous substance storage department, the construction characteristics of the facility, the characteristics of the technological process and the availability of the equipment used, it was concluded that the critical points are:</p> <ul style="list-style-type: none"> <li>• the reservoirs with their installation and fittings;</li> <li>and</li> <li>• the pipeline system.</li> </ul>	<p>The causes of failure in the storage system can be due to:</p> <ul style="list-style-type: none"> <li>• fire and explosion in the reservoir;</li> <li>• the very nature of the chemical reaction;</li> <li>• corrosion of the tank with its installations;</li> <li>• failures of locking and safety fittings;</li> <li>• mechanical breakage of pipelines due to severe corrosion.</li> </ul>	<pre> graph LR     A[REFILLING LIQUID HAZARDOUS SUBSTANCES] --&gt; B[Fire]     A --&gt; C[Tank corrosion]     A --&gt; D[Mechanical fracture]     B --&gt; E[Toxic cloud formation]     B --&gt; F[Destruction of the building]     C --&gt; G[Spillage onto the ground]     D --&gt; G     D --&gt; H[Evaporation]     </pre>

## CONCLUSION

The severity of the problem and the state of vulnerability to possible accidents during storage and handling of hazardous substances are affected by: obsolete and worn-out equipment, increasingly difficult maintenance of the plant due to the inability to procure materials and control instruments, frequent and sudden (unpredictable and predictable) downtime due to a lack of raw materials, spare parts, and equipment, work with no security systems control, diminished mental stability of workers, etc.

The high probability of accidents and environmental pollution indicates the need for daily risk assessment, and the development of policies to anticipate, prevent,

mitigate, and monitor significant negative impacts on people, property, and the environment.

To determine the degree of danger in case of accidents during storage and handling of hazardous substances, in addition to the characteristics of hazardous substances significant for assessing the impact on human safety and health, it is necessary to identify the process critical points and plant critical points, obtain the values of harmful substances, and determine in what amount and in what way they can uncontrollably be released from the plant.

Employees who are involved in transporting liquid fuels and who participate in the process of their refilling must be fully educated and trained to independently perform all actions related to the

transport and refilling of hazardous substances and to apply and adhere to all national and European legislation concerning the transport of dangerous goods.

## REFERENCES

Best Practice Guidelines (2013) *Best Practice Guidelines for Safe (Un)Loading of Road Freight Vehicles - covering Technical, Behavioural and Organisational Aspects*, Issue 1 - December 2013.

Available at:

<https://cefic.org/app/uploads/2021/09/Best-practice-guidelines-for-safe-Un-Loading-of-road-freight-vehicles-Corrigendum-2021-GUIDELINES-ROAD.pdf>

Chang, J.I. and Lin, C.C. (2005). A study of storage tank accidents. *Journal of Loss Prevention in the Process Industries*, 19: 51–59. DOI:10.1016/j.jlp.2005.05.015

ECE/TRANS/275 (2015) European Agreement Concerning the International Carriage of Dangerous Goods by Road – ECE/TRANS/275 (so called ADR) (Annexes A and B), United Nations Economic Commission for Europe (UNECE)

Festić, E. and Imamović, A. (2021). Značaj edukacije i opšti uslovi za bezbjedan transport opasnih materija prema ADR-u, *Zaštita i sigurnost*, godina 1., broj 2., str. 95-106.

Fuentes-Bargues, J., González-Cruz, M., González-Gaya, C., et al. (2017). Risk Analysis of a Fuel Storage Terminal Using HAZOP and FTA. *International Journal of Environmental Research and Public Health*, 14 (7): 705. doi:10.3390/ijerph14070705

Gašić, M. (2002). *Zaštita od požara i eksplozija*, Univerzitet u Banjoj Luci, Mašinski fakultet, Banja Luka.

IECEX and ATEX Certification: Product marking, <https://presafe.dk/standard/iecex-and-atex-certification-product-marking> [Accessed 23.6.2022.].

Krstić, V. (2017). Rizici i mogućnosti njihovog smanjenja pri transportu opasnog tereta u drumskom saobraćaju, in *Proceedings, Volume 2, 12th International Conference "Road Safety in Local Community" Serbia, Tara, Hotel Omorika, April 19 – 22, 2017*, pp. 93-100.

Poljak, L. (2013). *Priručnik za prevoz i manipulaciju opasnim teretima*, IV izdanje, Institut za preventivu, zaštitu na radu, protivpožarnu zaštitu i razvoj d.o.o., Novi Sad.

Pravilnik o izgradnji stanica za snabdijevanje gorivom motornih vozila i o uskladištenju i pretakanju goriva, Službeni glasnik Republike Srpske, broj 26/2012, Banja Luka, 2012.

Šobat, N. (2017). Mjere za unapređenje bezbjednosti prilikom pretakanja tečnih opasnih materija, Završni rad II ciklusa studija, Univerzitet u Banjoj Luci, Mašinski fakultet, Banja Luka.

## BIOGRAPHY of the first author

**Nikola Šobat** was born in Drvar, B&H, in 1973.

He received a diploma in mechanical engineering (department occupational safety) and a Msc degree in occupational safety from the University of Banja Luka, Faculty of Mechanical Engineering.

President of the Association of Occupational Safety and Health Engineers in the Republic of Srpska. Employed he as a manager in the Institute for Textbooks and Teaching Aids of the Republic of Srpska. President of the Union of Media and Graphic Artists of Republika Srpska.



TATJANA GOLUBOVIĆ<sup>1</sup>  
ANA BIJELIĆ<sup>2</sup>

<sup>1,2</sup>University of Niš,  
Faculty of Occupational Safety

<sup>1</sup>tatjana.golubovic@znrfak.ni.ac.rs

<sup>2</sup>ana.miltojevic@znrfak.ni.ac.rs

## BROMINATED FLAME RETARDANTS: OCCUPATIONAL EXPOSURE AND TOXICITY

**Abstract:** *The need for flame retardants increased with the invention of new materials. Flame retardants are a diverse group of chemicals incorporated into potentially flammable materials, such as plastics, rubbers, wood and textiles, used for fire prevention and inhibition. Flame retarded polymers are widely used in electrical equipment, computers, building materials, cars, etc. Flame retarded textiles are particularly used in the upholstery of cars, aircraft and trains. Brominated flame retardants (BFRs) are a significant group of flame retardants with more than 80 different aliphatic, cyclo-aliphatic, aromatic, and polymeric compounds, such as polybrominated biphenyls (PBBs), polybrominated diphenyl ethers (PBDEs), hexabromocyclododecane (HBCD), and tetrabromobisphenol A (TBBPA). Current global demand for brominated flame retardants is estimated at 350,000 tonnes per year. The dominant use of brominated flame retardants is particularly based on their high specific flame retardancy and good mixing properties with polymers. They have been used in several products in considerable amounts and consequently, they were detected in the working and living environment. Workers in different industries are occupationally exposed to brominated flame retardants. From an occupational view, workers can be exposed to flame retardants during primary production (e.g. chemical manufacturing), secondary production (e.g. foam production), downstream usage (e.g. spray polyurethane foam application), and decommissioning (e.g. electronic scrap workers). The presence of brominated flame retardants is linked with various adverse health effects, including endocrine disruption, reproductive/developmental toxicity, immunotoxicity, and neurotoxicity.*

**Key words:** brominated flame retardants, health effects, occupational exposure

## INTRODUCTION

The idea of using chemicals as flame retardants originates from ancient times. Namely, alum was used to minimize the flammability of wood by ancient Egyptians and Romans. Later, in the 17th to 19th century, ferrous sulphate and ammonium phosphate, as well as other inorganic salts were used as flame retardants. Increasing production of these substances has been observed in the 20th century, which coincided with the rise in the use of synthetic polymers. As plastics with high hydrogen-carbon content are more flammable than previously used materials, the request for better fire safety has increased. The increased use of electrical and electronic equipment, like computers, television sets, mobile phones, etc. has increased the demand for FRs in a new, technologically oriented society (Thuresson, 2004).

Flame retardants are a heterogeneous group of structurally and physico-chemically different chemicals. More than 175 various commercial FRs are available on the market. The annual global production of flame retardants is approximately 600,000 tonnes, of which about 350,000 tonnes are brominated flame retardants and 150,000 tonnes of polybrominated diphenyl ethers (Darnerud et al., 2001; Liakos et al., 2009).

Brominated flame retardants are currently the major market group due to their low cost and high-performance efficiency. Actually, there are more than 75 different BFRs recognized commercially (Birnbbaum et al., 2004). As previously mentioned, BFRs are a very differentiated group of substances, including aliphatic, cycloaliphatic or aromatic compounds. These substances can be incorporated into the material to be protected in two different ways, either covalently

bonded or only added to the material. Among the BFRs, the main commercial are tetrabromobisphenol A (TBBPA), hexabromocyclododecane (HBCD), polybrominated diphenyl ethers (PBDEs) and polybrominated biphenyls (PBBs). PBDEs are not single chemical compounds, but rather mixtures of several brominated substances. The entire family of PBDEs consists of 209 possible substances that are referred to as congeners (US Department of Health and Human Services, 2017). Penta-BDE, octa-BDE and deca-BDE have been produced as commercial PBDE formulations (US Department of Health and Human Services, 2004). Due to adverse health effects, penta- and octa- commercial PBDEs were banned by the European Union in 2004 (Prevedouros et al., 2004) and voluntarily phased out in the US (Ward et al., 2008). In 2009, commercial octa-BDE and penta-BDE were recognized as persistent organic pollutants (POPs) with the potential of causing harmful effects, why they were added to the list of POPs under the Stockholm Convention (UNEP 2009), and the deca-formulation was added in 2017 (House, 2017). However, PBDEs will continue to be released during end-of-life activities for products produced before their use was banned.

The main routes of human exposure to brominated flame retardants are ingestion, inhalation, as well as dermal. As regards the general population, exposure through food, particularly via contaminated fish, poultry and beef is the predominant route of exposure (Thuresson, 2004; Athanasiadou, 2003; Eljarrat et al., 2005). Also, a significant route of exposure to brominated flame retardants is the inhalation of contaminated air and dust, which seems to be related to their release from electrical equipment, furniture and building materials. Dermal uptake of brominated flame retardants, in general population, is of minor importance (Sjödin et al., 2003).

Workers employed at workplaces such as the production and manufacture of PBDE-containing plastics and plastic products, computer monitor repair technicians, workers at plants that deconstruct electronic tools, production of printed circuit boards, production of expanded polystyrene foam and extruded polystyrene foam, etc. are occupationally exposed to flame retardants (Sjödin et al., 2003; Zhou et al., 2014; U.S. Environmental Protection Agency, 2010).

Industrial workers are mainly exposed to different brominated flame retardants through the following three pathways: dust ingestion, dust dermal contact and airborne particulate matter inhalation (Abdallah et al., 2018). Flame retardants associated with airborne particles, present at elevated levels, cause harmful effects to the occupationally exposed workers (Zhou et al., 2014). The degree of worker exposure depends on the production process and the exposure pathway.

The health effects related to exposure to BFRs were summarised into five subgroups: (1) thyroid disorders (2) diabetes (3) reproductive health (4) cancers and (5) neurobehavioral and developmental disorders (Kim et al., 2014).

## **BROMINATED FLAME RETARDANTS**

Flame retardants can be classified into two major groups, inorganic and organic (halogenated and organophosphate) compounds.

Halogenated flame retardants are particularly based on chlorine and bromine and they can be divided into three classes: aromatic, cycloaliphatic and aliphatic. It is important to note that aromatic flame retardants include the main brominated flame retardants, tetrabromobisphenol A and decabromodiphenylether, while cycloaliphatic group includes the hexabromocyclododecane isomers. Aliphatic substances are minor group of flame retardants.

With the increasing consumption of thermoplastics and thermosets for applications in electrical engineering and electronics, buildings, and transportation, a diversity of flame retarded materials have been developed over the past four decades. Table 1 gives an overview of flame retarded materials applications.

Brominated flame retardants can be used as additive as well as reactive.

Additive flame retardants are included into the polymer before, during, or after polymerization, without chemical bonding. As a result, they may be released from the polymer to the environment.

Reactive flame retardants are added during the polymerisation process and become a structural part of the polymer. The result is a modified polymer with flame-retardant properties and a different structure in contrast to the native polymer molecule. This prevents flame retardants release from the polymer and keeps the flame retardant properties intact over time with low emissions to the environment (Harju et al., 2008; Danish EPA, 1999).

Despite the fact that the use of halogenated flame retardants is seriously questioned due to their potential negative effects on the environment and human health, they account for about 25% of the world's total production of flame retardants by volume and are growing at a rate of about 5% annually (Harju et al., 2008; Fink et al., 2005).

Brominated flame retardants are increasingly present in the environment and in humans. The adverse health effects of these chemicals can be connected to their persistence, bioaccumulation and biomagnification potential (Eljarrat et al., 2004).

The main routes of exposure are some kind of food, inhalation, and ingestion via dust in indoor environments and occupational exposure.

Some of the adverse health impacts causing by brominated flame retardants are an improper function of thyroid hormones, damage to the nervous system, liver, kidney, and reproductive and immune systems (Kim et al., 2014).

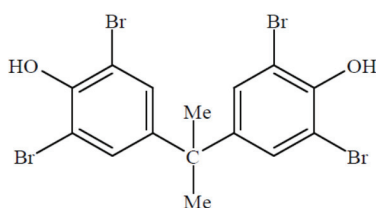
Brominated flame retardants should be studied systematically to assess their possible influence on human health and the environment.

**Table 1.** Application of flame retarded materials

Industry	Application
electrical engineering, electronics	cover of television sets and computers, plugs, spacers, shield of cables
buildings, mining industry	building materials, paints, isolations, heating materials
furniture industry	upholstery containing polyurethane foam, adhesives
transportation	interior fittings of private vehicles and public transport
textile industry	clothes

## TETRABROMOBISPHENOL A

Tetrabromobisphenol A (2, 2', 6, 6'-tetrabromo-4, 4'-isopropylidenediphenol) is used primarily as a reactive flame retardant in epoxy resin circuit boards incorporate in electrical and electronic equipment and latterly in electronic enclosures made of polycarbonate-acrylonitrile-butadiene-styrene. Tetrabromobisphenol A is covalently bound to plastic, resulting in no free TBBPA in the final product. Besides its use in polymers, applications of TBBPA include its use as a chemical intermediate for the synthesis of other flame retardants, fire retardant additives, as well as fire-retardant polycarbonate comonomer (HSDB, 2001; IPCS/WHO, 1995). The chemical structure of tetrabromobisphenol A is given in Fig. 1.



**Figure 1.** Chemical structure of tetrabromobisphenol A (TBBPA)

TBBPA is found in the environment as a result of emission at production sites, or likely more importantly

via release from products where it has been included as an additive flame retardant.

TBBPA as a highly lipophilic compound has low water solubility (Stojanović et al., 2014).

By reaching the water TBBPA is likely to adsorb to suspended solid particulates and sediment.

If released into the air, TBBPA is expected to exist completely in the particulate phase. Wet and dry deposition is the dominant atmospheric deposition mechanisms of particulate TBBPA.

In soil, TBBPA is usually tightly bound to soil particles. Under anaerobic conditions, TBBPA is expected to undergo rapid primary degradation and slow mineralization in some soils, depending on the type and composition of the soil, temperature, acidity and humidity (Golubović, 2020).

Regarding persistence, TBBPA half-life values are 44-179, 48-84, and 1-9 days in soil, water and air, respectively (U.S. EPA, 1999a; cited by U.S. EPA, 2002a; U.S. EPA. 1999b).

Bioconcentration factors (BCFs) ranging from 20 to 3200 suggest that bioconcentration is generally moderate to high in aquatic organisms.

A permanent increase in human exposure to TBBPA and other brominated flame retardants has been noticed.

Possible routes of TBBPA exposure could be the presence of these substances in the work and living environment.

For the general population, exposure to TBBPA is possible from inhalation of ambient air, dermal contact with the compound and ingestion of TBBPA. As well, TBBPA has been found in food (particularly in fish and shellfish).

Occupational exposure to TBBPA may occur via dermal contact during its production or use in the workplace or via inhalation of dusts.

The available data for humans indicates that TBBPA is present in some samples of blood plasma, especially those related to occupational exposure. However, TBBPA has also been found, in lower concentration, in analysed samples taken from the general population. The most examined groups of workers are from the following professions: electronic equipment dismantlers, circuit board producers, computer technicians, smelter workers, laboratory personnel, etc.

The conclusion of a study on TBBPA contamination in various printed circuit board (PCB) production processes and potential worker exposure to TBBPA is that work-related indoor environments that deal with TBBPA or material containing TBBPA may have higher levels of contamination than non-work-related microenvironments. The variation in worker exposure to TBBPA depended on the printed circuit board production process and the exposure pathway. The estimated values were significantly higher in some processes, e.g., the raw material warehouse and



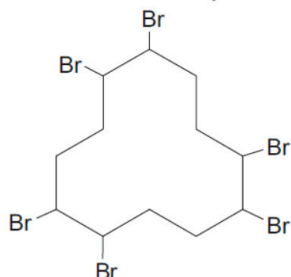
lamination. Additionally, dust ingestion contributed to higher TBBPA exposure than dust dermal contact and PM10 inhalation in most production processes of this plant (Zhou et al., 2014).

In rooms containing computers and other electrical equipment, it was confirmed that all air particulate samples contained TBBPA (de Wit, 2000).

Tetrabromobisphenol A is classified as a 2A, probably carcinogenic to humans by the International Agency for Research on Cancer (Oral et al., 2021). TBBPA has a low incidence of acute toxicity, but chronic exposure may produce serious consequences. Various studies indicate that TBBPA acts as an endocrine disruptor, causing neurobehavioral and immunotoxic effects, oxidative stress, and apoptosis. Despite the fact that several experiments were realized *in vitro* and *in vivo*, human data are lacking, and consequently, the chronic toxic effects of TBBPA on humans are not well known. Epidemiological studies that comprehensively assess TBBPA levels in biological fluids of different populations and different pathological conditions are needed (Oral et al., 2021).

## HEXABROMOCYCLODODECANE

Hexabromocyclododecane (HBCD) is an aliphatic, brominated cyclic alkane consisting of 12 carbon, 18 hydrogen, and 6 bromine atoms bonded to the ring (Fig. 2).



**Figure 2.** Chemical structure of hexabromocyclododecane (HBCD)

Bromination of cyclododeca-1,5,9-trienes theoretically results in 16 stereoisomers—6 enantiomeric pairs and 4 meso forms.  $\alpha$ ,  $\beta$  and  $\gamma$ -HBCD stereoisomers dominate in technical products. HBCD is the third most commonly used brominated flame retardant.

The most important use of HBCDs, due to their high efficiency at low concentrations, is as flame retardants in expanded polystyrene foam and extruded polystyrene foam. They are used particularly for thermal isolation boards in the building and construction industry. HBCD may also be used as a flame retardant in textiles for upholstered furniture, upholstery seating in transportation vehicles, draperies, wall coverings, and rubber and plastic products. Additionally, HBCD is used as a flame retardant in high-impact polystyrene for electrical and electronic devices such as audio-visual equipment, and certain wire and cable applications.

HBCD flame retardants are solid substances with negligible to low water solubility. Based on the available bioaccumulation and persistence data, Environmental Protection Agency (EPA) has determined that HBCD should be classified as a persistent, bioaccumulative, and toxic chemical.

HBCD has been detected in almost all environmental media and is considered to be a ubiquitous contaminant.

HBCD has been detected in air at very remote sites, suggesting that it undergoes long-range atmospheric transport.

Due to their hydrophobic character, HBCDs are strongly bound to solid particles such as soil, sediment, and sewage sludge. The high amounts of HBCDs in sewage sludge are a result of diffuse leaching from flame-retarded products into wastewater streams. Applying these sludges to agricultural or other lands may redistribute the contained HBCD to the soil-sediment compartment and further into aquatic or terrestrial food chains (Law et al., 2005).

HBCD has been found in river sediments downstream of urban centers or known industrial sources. HBCD has also been detected in both freshwater and marine biota (Law et al., 2005).

The main intake of HBCD for the general population is from food, outdoor air, particularly near point sources and indoor air or dust. Moreover, very high levels of HBCD have been discovered in household dust, suggesting that indoor exposure through inhalation or ingestion is very likely and may contribute significantly to human exposure.

HBCD is usually manufactured as a powder of about 100 microns in diameter. Still, a part of the materials is micronized to 1 micron during manufacture, which poses the possibility of deep lung penetration. Particles 1 micron and smaller are able to penetrate into the alveolar sacs of the lungs. They may be absorbed into the blood or cleared through the lymphatics. The overall removal of particles from the alveoli is relatively non-effective (on the first day only about 20%). Some particles may remain in the alveoli permanently.

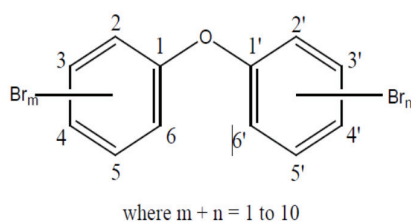
HBCD has been detected in human adipose tissue, milk, and blood.

## POLYBROMINATED DIPHENYL ETHERS

Polybrominated diphenyl ethers (PBDEs) are classes of structurally similar brominated hydrocarbons. There are 209 different congeners, although only a limited number exist in commercial mixtures. There are three main categories of commercial PBDE mixtures: penta-, octa-, and deca- brominated diphenyl ethers. The general chemical structure of PBDEs is given in Fig. 3.

In 2003, the European Union passed a Directive to ban the marketing and use of penta- and octa-BDE that took

effect in 2004. In 2008, the use of deca-BDE was restricted by the EU's Restriction of Hazardous Substances Directive.



**Figure 3.** Chemical structure of polybrominated diphenyl ethers (PBDEs)

Deca-BDE's major use was for electronic enclosures, such as television sets, computer housings, electronic components, printed circuit boards, furniture and textile. It is also widely used in the transportation, construction, and building sectors. Octa-BDE was mostly used in plastics for business equipment, television sets, computer housings, small electronics, etc. Penta-BDE was mainly used in foam for cushioning in upholstery, printed circuit boards, cable sheets and furniture. Regardless of the phase-out of penta-, octa-, and deca-BDEs, enormous content of consumer products still contain PBDEs.

PBDEs can be released into the air, water, and soil at places where they are produced or used. The important characteristics of PBDEs, persistent, low water solubility, high binding affinity to particles and a tendency to accumulate in sediments, explain their fate in the environment.

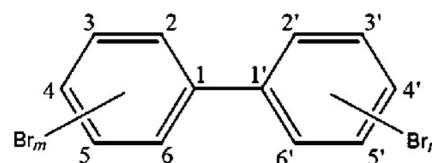
Humans are exposed to PBDEs by ingestion of contaminated foods, inhalation of air, ingestion of contaminated dusts or soils, and via dermal exposure.

Occupational exposure occurs primarily by inhalation of particulate-phase PBDEs, while inhalation of vapor-phase PBDEs is low due to the low vapor pressures of PBDEs. Occupational exposure may also likely involve oral exposure to particulate PBDEs as a result of a hand-to-mouth activity.

Occupational exposure to PBDEs occurs in workers in the production and manufacture of PBDE-containing plastics and plastic products, workers at plants that dismantle electronic equipment, computer monitor repair technicians, and automobile drivers. Also, firefighters seem to have higher exposure potential to PBDEs and other types of flame retardants in view of the fact that they are exposed to the combustion products of the flame retardants as well as the original forms of the chemicals. According to the total PBDEs in the serum of the firefighters, it can be seen that the levels of total PBDEs are approximately 40% greater when compared to the general population (Park et al. 2015). Generally, body burden data indicate higher concentrations for workers exposed to PBDEs than for the general population. Based on experimental studies, targets for PBDEs toxicity are the nervous system, liver, thyroid gland and development.

## POLYBROMINATED BIPHENYLS

Polybrominated biphenyls (PBBs) are a class of brominated hydrocarbons consisting of a central biphenyl structure to which 1-10 bromine atoms are attached (Fig. 4.). There are 209 different molecular combinations, or congeners, that are possible for PBBs.



**Figure 4.** Chemical structure of polybrominated biphenyls (PBBs)

Three commercial PBB mixtures were manufactured: hexabromobiphenyl, octabromobiphenyl, and decabromobiphenyl.

PBBs were used as fire retardant additives in plastics that were used in a variety of consumer products including furniture, textiles, electronic devices such as computer monitors and televisions, plastic foams, and other household products (US EPA, 2012).

PBBs exist predominantly in the particulate phase in the atmosphere. In water, PBBs are expected to adsorb strongly to suspended solids and sediment, and may bioconcentrate in aquatic organisms. As regards soil, PBBs are adsorbed to the solid phase.

The routes of potential human exposure to PBBs are ingestion, inhalation, and dermal contact. Residues remaining in and around facilities that previously manufactured, processed, or produced products using PBBs are sources of exposure.

Workers involved in the historical production of PBBs, PBB-containing plastics, and PBB-containing plastic products could have been exposed to PBBs via inhalation of dust and vapor and/or dermal contact.

The acute toxicity of PBBs is relatively low, but long-term effects on the balance of endocrine systems of humans seem to pose the most serious risk (De Boer et al., 2001).

## CONCLUSION

Brominated flame retardants represent the main industrial chemicals whose use has increased over the past few decades. They are produced to prevent fires and thus can have a direct and evident benefit. However, there is concern about their persistence, bioaccumulation, and potential for toxicity for humans. Different adverse health impacts, improper function of thyroid hormones, and damage to the nervous system, liver, kidney, and reproductive and immune systems, have been reported. Therefore, the presence of BFRs in

living and occupational environments should be continuously monitored.

## REFERENCES

- Abdallah, M.A-E., Harrad, S. (2018). Dermal contact with furniture fabrics is a significant pathway of human exposure to brominated flame retardants, *Environment International*, 118, pp. 26–33.
- Athanasiadou, M. (2003). Brominated flame retardants and related compounds in Baltic Sea wildlife - Chemical analytical methodology and assessment, Ph.D. Thesis, Department of Environmental Chemistry, Stockholm University.
- Birnbaum, L.S., Staskal, D.F. (2004). Brominated Flame Retardants: Cause for Concern?, *Environmental Health Perspective*, 112(1), pp. 9-17.
- Danish EPA (1999). Brominated flame retardants - substance flow analysis and assessment of alternatives. Copenhagen.
- Darnerud, P.O., Eriksen, G.S., Jóhannesson, T., Larsen, P.B., Viluksela, M. (2001). Polybrominated Diphenyl Ethers: Occurrence, Dietary Exposure, and Toxicology, *Environmental Health Perspectives*, 109(1), pp. 49-68.
- Department of Health and Human Services in USA (2017). *Toxicological profile for polybrominated biphenyls and polybrominated biphenyl ethers*. Agency for Toxic Substances and Disease Registry.
- Department of Health and Human Services in USA (2004). *Toxicological profile for polybrominated biphenyls and polybrominated biphenyl ethers*. Agency for Toxic Substances and Disease Registry.
- De Boer, J., De Boer, K., Boon, J. (2001). Polybrominated Biphenyls and Diphenylethers. In: Hutzinger, O., Paasivirta, J. (eds) Volume 3 Anthropogenic Compounds Part K. The Handbook of Environmental Chemistry, vol 3K. Springer, Berlin, Heidelberg.
- De Wit, C.A. (2002). An overview of brominated flame retardants in the environment, *Chemosphere*. 46, pp. 583–624.
- De Wit, C.A. (2000). Brominated flame retardants. Report 5065. Swedish Environmental Protection Agency. Elanders Gotab, Stockholm, Sweden, pp.95.
- Eljarrat, E., De la Cal, A., Raldua, D., Duran, C., Barcelo, D. (2005). Brominated flame retardants in *Alburnus alburnus* from Cinca River (Spain), *Environ. Pollut.*, 133, pp. 501-508.
- Eljarrat, E., De la Cal, A., Raldua, D., Duran, C., Barcelo, D. (2004). Occurrence and bioavailability of polybrominated diphenyl ethers and hexabromocyclododecane in sediment and fish from the Cinca River, a tributary of the Ebro River (Spain), *Environ. Sci. Technol.*, 38, pp. 2603–2608.
- Fink U., Hajduk F., Ishikawa Y. (2005). Flame Retardants, SRI Consulting.
- Golubović, T. (2020). Zagađivanje i zaštita zemljišta, Univerzitet u Nišu, Fakultet zaštite na radu u Nišu, Niš.
- Harju, M., Heimstad, E.S., Herzke, D., Sandanger, T., Posner, S., Wania, F. (2008). Current state of knowledge and monitoring requirements - Emerging "new" brominated flame retardants in flame retarded products and the environment. SFT, Oslo.
- HSDB (Hazardous Substances Data Bank). (2001). 2,2',6,6'-Tetrabromobisphenol A. Produced by the National Library of Medicine, Bethesda, MD.
- House, S.C. (2017). Information on the 16 chemicals added to the Stockholm Convention.
- IPCS/WHO (International Programme on Chemical Safety/World Health Organization). (1995). Environmental Health Criteria 172: Tetrabromobisphenol A and Derivatives. World Health Organization, Geneva, Switzerland. [online], available: <http://www.inchem.org/documents/ehc/ehc/ehc172>.
- Kim, Y.R., Harden, F.A., Toms, L-M. L., Norman, R. E. (2014). Health consequences of exposure to brominated flame retardants: A systematic review, *Chemosphere*, 106, pp. 1–19.
- Law, R., Kohler, M., Heeb, N., Gerecke, A., Schmid, P., Voorspoels, S., Covaci, A., Becher, G., Janák, K., Thomsen, C (2005). Hexabromocyclododecane challenges scientists and regulators, *Environ Sci Technol*, 39(13), pp.281A-287A.
- Liakos, I.L., Sarigiannis D., Gotti, A. (2009). PBDEs and PCBs in European occupational environments and their health effects, *WIT Transactions on Ecology and the Environment*, 123, pp. 365-374.
- Oral, D., Balci, A., Chao, M.W., Erkekoglu, P. (2021). Toxic Effects of Tetrabromobisphenol A: Focus on Endocrine Disruption, *Journal of Environmental Pathology, Toxicology, and Oncology*, 40(3), pp. 1-23.
- Park, H.R., Loch-Caruso, R. (2015). Protective effect of (+/-) alpha-tocopherol on brominated diphenyl ether-47-stimulated prostaglandin pathways in human extravillous trophoblasts in vitro, *Toxicol in Vitro*, 29(7), pp. 1309-1318.
- Prevedouros, K., Jones, K.C., Sweetman, A.J. (2004). Estimation of the production, consumption, and atmospheric emissions of pentabrominated diphenyl ether in Europe between 1970 and 2000. *Environ. Sci. Technol.* 38(12). pp. 3224–3231.
- Sjodin, A., Patterson, D.G.Jr., Bergman, Å. (2003), A review on human exposure to brominated flame retardants (BFRs) - particularly polybrominated diphenyl ethers (PBDEs), *Environ. Int.*, 29, pp. 829-839.
- Stojanović, M., Golubović, T. (2014). Osnovi opšte i neorganske hemije sa zadacima, Univerzitet u Nišu, Fakultet zaštite na radu u Nišu, Niš.
- Thuresson, K. (2004). Occupational Exposure to brominated Flame Retardants with Emphasis on Polybrominated Diphenyl Ethers, Department of Environmental Chemistry Stockholm University.
- UNEP. (2009). The 9 new POPs under the Stockholm Convention.
- U.S. Environmental Protection Agency. (2010). [online], available: <https://www.epa.gov>
- U.S. EPA. (1999a). 40 CFR Part 372: Persistent bioaccumulation toxic (PBT) chemicals; final rule. Cited by U.S. EPA (2002).
- U.S. EPA. (1999b). Virginia DEQ: SARA Title III Program: Persistent bioaccumulative toxic chemicals (PBTs). [online], available: <http://www.deq.state.va.us/sara3/pbt.html>
- US EPA (2012) Technical Fact Sheet-Polybrominated diphenyl ethers (PBDEs) and Polybrominated biphenyls (PBBs). EPA-505-F-11-007.
- Ward, J., Mohapatra, S.P., Mitchell, A. (2008). An overview of policies for managing polybrominated diphenyl ethers (PBDEs) in the Great Lakes basin. *Environ. Int.* 34(8), pp. 1148–1156.
- Zhou, X., Guo, J., Zhang, W., Zhou, P., Deng, J., Lin, K. (2014). Tetrabromobisphenol A contamination and emission

in printed circuit board production and implications for human exposure. *Journal of Hazardous Materials*. 273, pp. 27–35.

### ACKNOWLEDGEMENTS

The authors are grateful to the Ministry of Education, Science and Technological Development of the Republic of Serbia for the financial support of this work (contract number 451-03-68/2022-14/200148).

### BIOGRAPHY of the first author

**Tatjana Golubović** is a full professor at the University of Niš, Faculty of Occupational Safety. She is the Head of Chair of Occupational and Environmental Quality. She received the diploma and the Ph.D. degree in chemistry from the University of Niš, Faculty of Sciences and Mathematics.



Her main areas of research include chemistry, environmental chemistry, toxicology, ecotoxicology, and soil protection. She has published a lot of scientific papers on this subject and took part in the realization of a number of national and international research projects.





BOJAN BIJELIĆ<sup>1</sup>  
EVICA STOJILJKOVIĆ<sup>2</sup>

<sup>1,2</sup>University of Niš,  
Faculty of Occupational Safety

<sup>1</sup>bojan.bijelic@znrfak.ni.ac.rs  
<sup>2</sup>evica.stojiljkovic@znrfak.ni.ac.rs

## OBSERVATIONAL METHODS FOR ERGONOMIC RISK ASSESSMENT IN DENTAL PRACTICE

**Abstract:** *Dental profession is generally considered a great career choice and an easy, enjoyable job. However, this misconception conceals a very hard and demanding profession, which unfortunately can cause serious health consequences for the people who practice it. One of the most common negative phenomena that result from dealing with dentistry is work-related musculoskeletal disorders. These disorders come with several consequences, including a reduced quality of life, frequent sick leaves, career changes, or even early retirement. The complexity of the work in the dental office imposes the need to conduct a thorough ergonomic analysis of the entire system.*

*The main reason for the frequent occurrence of work-related musculoskeletal disorders in dentists is their daily exposure to numerous ergonomic risk factors in dental offices. Among these factors, the most important is the dentist's work posture, as work in the dental office is characterized by frequent awkward postures, static work, and repetitive movements. Adequate analysis of work postures in the dental office and assessment of the influence of work postures on the development of musculoskeletal disorders is a very important part of an ergonomic analysis.*

*Analysis of work postures can be performed by using various methods for assessing ergonomic risk factors. The most numerous and, due to the simplicity of application, the most frequently used group of methods for the analysis of work postures are observational methods, which can even be applied by dentists themselves. However, a large number of observational methods can make it significantly more difficult to choose the right method, which is one of the preconditions for obtaining relevant results.*

*In this paper, the analysis of observational methods that are most suitable for the assessment of ergonomic risk factors in dentistry will be performed. The results of this analysis will enable an easier selection of the appropriate method and thus contribute to a better analysis of ergonomic risk factors.*

**Key words:** musculoskeletal disorders, ergonomic risk, observational method, dentistry.

## INTRODUCTION

Dentistry is a very complex profession from an ergonomic standpoint. Due to exposure to a large number of ergonomic risk factors, dentists are at high risk of developing a range of different work-related musculoskeletal disorders (WRMSD). WRMSDs are various degenerative and inflammatory conditions affecting different parts of the musculoskeletal system, such as blood vessels, peripheral nerves, joints, ligaments, tendons, and muscles (Korhan & Memon, 2019).

WRMSDs have a negative impact on the quality of work and life of dentists. Five dentistry-related jobs are ranked in the top 10 unhealthy jobs in the US, based on

the data from the Occupational Information Network (O\*NET) database (Keirs et al., 2020). The incidence of lower back pain is twice as higher in US dentists than in US adult general population, while the incidence of neck pain in US dentists is five times higher (Blackwell et al., 2014; ADA, 2017). Dentists are often forced to consider carrier change or early retirement due to WRMSDs.

Prolonged static work, repetitive movements, constant bending and twisting of the neck and spine, and awkward postures are the main risk factors for the development of WRMSDs in dentistry (Hosseini et al., 2019). Postures are one of the most important risk factors that need to be analysed when performing an

ergonomic risk assessment in dentistry. Working while maintaining a good posture reduces the stress level, and muscular tension and increases comfort in dentists (Pîrvu et al., 2014). On the other hand, awkward postures cause pain and stiffness in muscles and joints, mainly in the shoulder, lower back, and neck area. Such compromised postures are unfortunately quite frequent in dental practice.

Postural analysis is most often performed by using observational ergonomic methods. There are numerous observational methods, however, only a few are generally accepted and used by the ergonomist worldwide. Choosing the right observational method is very important and has a significant impact on the results' validity.

To facilitate the choice of a method for assessing ergonomic risks in dentistry, this paper will analyse the methods most suitable for use in dentistry.

### OBSERVATIONAL METHODS USED IN DENTISTRY

Observational methods are often used for the analysis of ergonomic risks in dentistry. However, there are only a few observation methods that are specially designed for use in dentistry. Three such methods found by a literature review are Postural Assessment Instrument (PAI) (Branson et al., 2002), Modified-Dental Operator Posture Assessment Instrument (M-DOPAI) (Partido, 2017), and Standardized Photometric Assessment (SPAM) (Muthuraj et al., 2020).

These dentistry-specific methods are used much less than general methods for ergonomic risk assessment. Based on the number of published papers Rapid Entire Body Assessment (REBA) is the most widely used method for assessing ergonomic risk in dentistry, by far. Rapid Upper Limb Assessment (RULA), PAI, and M-DOPAI are used approximately the same, and there is evidence of several other methods used a couple of times. Other methods are rarely used in dentistry (Figure 1.).

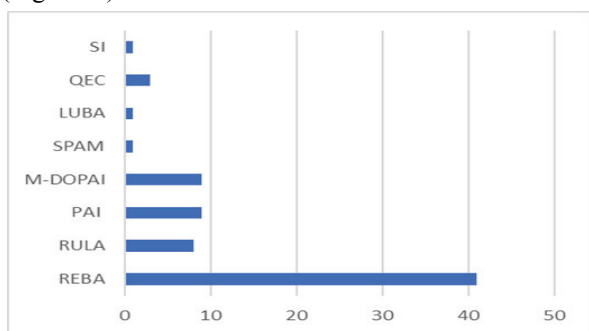


Figure 1. Most used observational methods per number of papers

Analysis of ergonomic risk by observational methods consists of observing the work process and awarding points following the used methods. Observation of the work process can be done by watching the worker directly, by analysing the video recordings or

photographs of the work process (Hita-Gutiérrez et al., 2020).

Rapid Entire Body Analysis (REBA) is an observation method for postural analysis intended for use of work postures in the healthcare and service industries (Hignett & McAtamney, 2000). REBA is widely accepted in different industries and is probably the most often used method for ergonomic risk assessment. This simple method can be used both in a laboratory or in real-life conditions with the use of just a pen and paper. Postural analysis performed with REBA take into account the position of the following body part upper and lower arms, wrists, legs, neck, and head. Besides this, REBA analyses the force/load, movements' repetition, activity, and coupling (Madani & Dababneh, 2016). The reliability of REBA results can be improved with the implementation of modern technologies, such as the use of inertial sensors for postural assessment (Arendra et al., 2020) or deep learning methods for the analysis of posture for videos (Yu et al., 2019).

Rapid Upper Limb Assessment (RULA) is designed for ergonomic analysis of workplaces with reported work-related upper arm musculoskeletal disorders (McAtamney & Corlett, 1993). REBA was developed based on this method; therefore, REBA and RULA are very similar in certain parts. Ergonomic analysis of a workplace with the use of the RULA method focuses on positions of the trunk, neck, upper and lower arms, and wrists. Legs are also mentioned in the RULA worksheet, but this can be disregarded as it only analyses if legs are supported or not. RULA takes into account the repetitive movements, static postures, and force/load. Using inertial sensors to analyse body part position improves the result of the RULA method (Blume et al., 2021; Maurer-Grubinger et al., 2021).

The dental operator Posture Assessment Instrument (PAI) is the first observational method designed especially for use in dentistry. This method analyses the work posture that dentists make when working with a patient together with the time that dentists keep a specific position. PAI methods require analysis of the positions of hips, trunk, shoulders, wrists, head, and neck (Branson et al., 2002). PAI method examines ten different postural components, and based on their scoring, work postures can be categorized as acceptable, compromised, and harmful.

Modified Dental Operator Posture Assessment Instrument (M-DOPAI) is developed by Partido (2017) and is a modified version of the PAI method. The only changes compared to the original PAI method are that M-DOPAI additionally analyses the upper arms position, so the M-DOPAI consists of 12 postural components. Assessment of the upper arms positions is performed based on the Posture Assessment Criteria proposed by Maillet et al. (2008). M-DOPAI is designed as a photograph-based self-assessment tool and is limited to posture analysis.

The standardized photometric assessment method (SPAM) is a more recent method, with only one paper in which the method is described and validated. SPAM is designed as a postural analysis tool (Muthuraj et al., 2020). This method analyses eight different postural requirements proposed by Grubin et al. (2011). Analysis of work postures by SPAM method is done from photographs. The method gives straightforward guidelines on how dentists should be photographed so that the results are comparable. These guidelines are related to the camera position and the use of visual reference aid for comparison, which are used for determining the distances and angles (Muthuraj et al., 2020).

**ADVANTAGES AND DISADVANTAGES OF OBSERVATIONAL METHODS USED IN DENTISTRY**

Observational methods generally have good cost efficiency and don't require additional training. All previously mentioned methods have been verified and used in real-life scenarios. These methods share a couple of advantages and disadvantages that are typical for observational methods.

Observational methods often interfere with the work process, which can cause the Hawthorne effect. The Hawthorne effect can be described as a change in workers' behaviour that happens as a response to the fact that their work is being observed and assessed (Sedgwick & Greenwood, 2015). If workers are aware that the way they work is observed and assessed by someone, they are more likely to differ from the way they normally work.

Around 30 % of all ergonomic assessments done with the use of observational methods have some errors, which can often make the result of such assessments invalid (Diego-Mas et al., 2017). The main reasons for these errors are the lack of knowledge and experience of the assessors (Diego-Mas et al., 2017). Observers' bias is also a common disadvantage for observational methods.

Assessment of ergonomic risk should account for the following three ergonomic exposure indicators: intensity of the workload, duration of the workload, and frequency of the workload (Steinberg, 2012). None of the methods commonly used in dentistry meet this criterion (Table 1).

*Table 1. Observational methods and the ergonomic exposure indicators*

Method	Intensity	Duration	Frequency
RULA	Yes	No	No
REBA	Yes	No	No
PAI	Yes	Yes	No
M-DOPAI	Yes	No	No
SPAM	Yes	No	No

Most observational methods are focused on individual postures without analysing the sequence of different postures that a worker takes during his work. Also, many observational methods asses only selected parts of the human body (Table 3.)

*Table 2. Body parts assessed by a specific observational method*

	REBA	RULA	PAI	M-DOPAI	SPAM
Hips			x	x	
Trunk	x	x	x	x	x
Head/Neck	x	x	x	x	x
Shoulders			x	x	
Wrist position	x	x	x	x	
Wrist twist		x			
Upper Arms	x	x		x	x
Lower Arms	x	x			x
Lower Legs	x				x
Upper Legs	x				x

REBA is a great tool for ergonomic risk assessment that is used throughout different industries. Since REBA is used for the analysis of the whole body it's seemingly ideal for use in dentistry. However, one major disadvantage of this method is the way that seated postures are assessed. REBA just lacks a proper module for assessing seated postures, and in modern dentistry, most of the work is done while seating.

RULA focuses on the upper body assessment, which is a big disadvantage for its use in dentistry. Dentists can work in both seated and standing positions, and the lower body is under a stress in either position. Therefore, the lower body must be considered in an assessment of ergonomic risks in dentistry.

Both RULA and REBA methods are assessing wrist positions in a simplified way, which is not suitable for dentistry as dentists make very specific wrist positions during their work. RULA and REBA do not require any advanced knowledge in ergonomics or any additional equipment, as they were designed as a pen-and-paper method.

PAI is intended for postural analysis of dentist work and it focuses only on working in seated positions. This is a disadvantage, as many dentists still work in a standing position or combine work in standing and seated positions. The main advantage of this method is that it analyses the time that a worker spends in a specific work position.

M – DOPAI, the same as the original PAI method based on which it was developed, is that it focuses on work in a seated position. M – DOPAI's advantage compared to the PAI is that it analyses the upper arm position. An important disadvantage of this method is a lack of a standardized method for photographing,

which can make the results of assessments performed by different observers incomparable (Muthuraj et al., 2020). Times spent in a different work position are not taken into account by M-DOPAI.

The SPAM method has a standardized protocol for photographing the work position, which makes the result comparable. Analysis of work postures by this method is cheap and without interruption to the work process. Unfortunately, this method is limited to analysis of seated work only.

All methods mentioned above are focused mainly on postural analysis. Other biomechanical risk factors that dentist is exposed to during their work are not considered.

## CONCLUSION

Making a proper ergonomic risk assessment by using observational methods can be quite challenging, mainly because of the number of existing methods. Choosing the right observational method for a specific situation will have a large influence on the quality of the results. Generally speaking, each observational method has some advantages and disadvantages, making them more or less suitable for use in assessing specific jobs. Results of such assessment will mainly depend on the conditions under which observational methods are applied and which resources are available to the assessors. Observational methods should always be used in a such way that allows for avoiding the Hawthorne effect.

Existing researches with an application of observational methods for ergonomic risk assessment in dentistry clearly show that a single method can only give a partial result. This is due to the complexity and the number of different ergonomic risk factors that dentists are exposed to. So, making an adequate ergonomic risk assessment in dentistry by only using observational methods is almost impossible. To get the best result from ergonomic risk assessment, the most suitable option would be to combine self-reporting, observational and technical methods.

## REFERENCES

Al Madani, D., & Dababneh, A. (2016). 'Rapid entire body assessment: a literature review', *American Journal of Engineering and Applied Sciences*, 9(1), 107-118.

American Dental Association. (2017). '2015 Dentist Well-being and Survey Report', ADA.

Andreas, G. W. J., & Johansson, E. (2018). 'Observational methods for assessing ergonomic risks for work-related musculoskeletal disorders. A scoping review', *Revista Ciencias de la Salud*, 16(SPE), 8-38.

Arendra, A., Akhmad, S., & Lumintu, I. (2020). 'Working tool redesign to reduce ergonomic risk of salt evaporation field workers based on RULA and REBA assessments using esMOCA Instrument', *Journal of Physics: Conference Series* (Vol. 1477, No. 2, p. 022034). IOP Publishing.

Blackwell, D. L., Lucas, J. W., & Clarke, T. C. (2014). 'Summary health statistics for US adults: national health interview survey, 2012', *Vital and health statistics. Series 10, Data from the National Health Survey*, (260), 1-161.

Blume, K. S., Holzgreve, F., Fraeulin, L., Erbe, C., Betz, W., Wanke, E. M., Brueggmann, D., Nienhaus, A., Maurer-Grubinger, C., Groneberg, D. A., & Ohlendorf, D. (2021). 'Ergonomic Risk Assessment of Dental Students — RULA Applied to Objective Kinematic Data', *International Journal of Environmental Research and Public Health*, 18(19), 10550.

Branson, B. G., Williams, K. B., Bray, K. K., McIlroy, S. L., & Dickey, D. (2002). 'Validity and reliability of a dental operator posture assessment instrument (PAI)', *Journal of Dental Hygiene*, 76(4).

Diego-Mas, J. A., Alcaide-Marzal, J., & Poveda-Bautista, R. (2017). 'Errors using observational methods for ergonomics assessment in real practice', *Human factors*, 59(8), 1173-1187.

Garbin, A. Í., Garbin, C. A. S., Diniz, D. G., & Yarid, S. D. (2011). 'Dental students' knowledge of ergonomic postural requirements and their application during clinical care', *European Journal of Dental Education*, 15(1), 31-35.

Hignett, S., & McAtamney, L. (2000). 'Rapid entire body assessment (REBA)', *Applied ergonomics*, 31(2), 201-205.

Hita-Gutiérrez, M., Gómez-Galán, M., Díaz-Pérez, M., & Callejón-Ferre, Á. J. (2020). 'An overview of REBA method applications in the world', *International journal of environmental research and public health*, 17(8), 2635.

Hosseini, A., Choobineh, A., Razeghi, M., Pakshir, H. R., Ghaem, H., & Vojud, M. (2019). 'Ergonomic assessment of exposure to musculoskeletal disorders risk factors among dentists of Shiraz, Iran', *Journal of Dentistry*, 20(1), 53.

Kiersz, A., Gillett, R., & Hoff, M. (2020). '47 jobs that will always be bad for your health, and how much they pay', *Business Insider*, [online], available: <https://www.businessinsider.com/most-unhealthy-jobs-in-america-2017-4> [Accessed 08 Sept 2022].

Korhan, O., & Memon, A. A. (2019). 'Introductory chapter: work-related musculoskeletal disorders. In *Work-related musculoskeletal disorders*', IntechOpen.

Maillet, J. P., Millar, A. M., Burke, J. M., Maillet, M. A., Maillet, W. A., & Neish, N. R. (2008). 'Effect of magnification loupes on dental hygiene student posture', *Journal of dental education*, 72(1), 33-44.

Maurer-Grubinger, C., Holzgreve, F., Fraeulin, L., Betz, W., Erbe, C., Brueggmann, D., Wanke, E. M., Nienhaus, A., Groneberg, D. A., & Ohlendorf, D. (2021). 'Combining ergonomic risk assessment (RULA) with inertial motion capture technology in dentistry — Using the benefits from two worlds', *Sensors*, 21(12), 4077.

McAtamney, L., & Corlett, E. N. (1993). 'RULA: a survey method for the investigation of work-related upper limb disorders', *Applied ergonomics*, 24(2), 91-99.

Muthuraj, T. S., Raja, J., James, J. R., Raj, J. P. M., Subramnian, D., & Varatharajan, A. (2020). 'Standardized photometric assessment method: A novel approach for the analysis of dental ergonomic posture', *Journal of Indian Society of Periodontology*, 24(3), 227.

Partido, B. B. (2017). 'Dental hygiene students' self-assessment of ergonomics utilizing photography', *Journal of dental education*, 81(10), 1194-1202.

Pîrvu, C., Pătraşcu, I., Pîrvu, D., & Ionescu, C. (2014). 'The dentist's operating posture-ergonomic aspects. *Journal of medicine and life*', 7(2), 177.

Sedgwick, P., & Greenwood, N. (2015). 'Understanding the Hawthorne effect', *BMJ*, 351.

Steinberg, U. (2012). 'New tools in Germany: development and appliance of the first two KIM ("lifting, holding and carrying" and "pulling and pushing") and practical use of these methods', *Work*, 41 (Supplement 1), 3990-3996.

Yu, Y., Yang, X., Li, H., Luo, X., Guo, H., & Fang, Q. (2019). 'Joint-level vision-based ergonomic assessment tool for construction workers', *Journal of construction engineering and management*, 145(5), 04019025.

## ACKNOWLEDGEMENTS

The research is funded by the Ministry of Education, Science and Technological Development of the Republic of Serbia.

## BIOGRAPHY of the first author

**Bojan Bijelić** was born in Skopje, Republic of Macedonia, in 1985.

He received a diploma in occupational safety from the University of Niš, Faculty of Occupational Safety in Niš. He is currently a Ph.D. candidate at the same faculty.

His main areas of research include ergonomics, safety engineering, etc.

He is currently working as a Teaching Assistant at the Faculty of Occupational Safety in Niš, University of Niš.







MIODRAG ŽIVANČEV<sup>1</sup>  
BOJANA ZORAJA<sup>2</sup>  
DEJAN UBAVIN<sup>3</sup>  
DUŠAN MILOVANOVIC<sup>4</sup>

<sup>1,2,3,4</sup>University of Novi Sad,  
Faculty of Technical Sciences,  
Department of Environmental  
Engineering and Occupational Safety

<sup>1</sup>miodragzivancev@uns.ac.rs

<sup>2</sup>bojanazoraja@uns.ac.rs

<sup>3</sup>dejanubavin@uns.ac.rs

<sup>4</sup>dusanmilovanovic@uns.ac.rs

## OCCUPATIONAL HEALTH & SAFETY RISKS IN MATERIAL RECOVERY FACILITIES

**Abstract:** Waste management sector in Serbia is in its developing phase. In order to comply with EU regulation in the field of recycling, new material recovery facilities (MRFs) with specific workplaces must be constructed. This paper addresses occupational health and safety risks for workers in MRFs and outlines proposals for improvement of working conditions, as well as risk mitigation measures. Data presented in this paper were obtained from questionnaires and literature, from the results of a field research, and from occupational safety risk assessment. The collected data were used to recognize and evaluate health and safety risks and to propose preventive measures and improved operation procedures. Some of the recognized risks include exposure to various dust emissions, maintaining the same body position during work, presence of heavy machinery, noise, and sharp objects. Several preventive measures were proposed, and guidelines were developed for each recognized risk. Due to specific workplace conditions, it is necessary to equip and train all employees in MRFs, with the aim to minimize the number of accidents and injuries. The improvement proposal also recommends hiring external professional consulting services and includes more focused and extensive considerations regarding safety and health at work.

**Key words:** occupational risk, risk assessment, waste management, material recovery facility

### INTRODUCTION

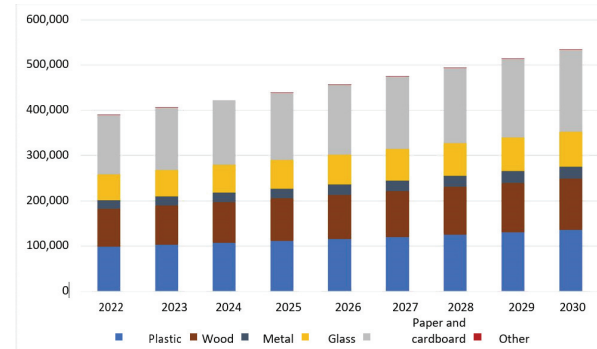
Collection, treatment, and disposal of municipal and industrial waste are the main operations in the waste management sector. Each of these operations requires specific facilities. The importance of waste management sector has increased, because environmental awareness is at a higher level and legislation in this field has become stricter (Rodrigues et al., 2020).

Jobs in the waste management sector include drivers, waste bin handlers, heavy machinery operators, and workers in waste treatment facilities, among which the waste sorters who manually sort waste are of particular interest in this paper. In order to implement increased recycling mandates and due to increased waste generation rate, a growing number of material recovery facilities may be expected (Jamison et al., 2014).

For the projection of the amount of generated municipal waste by 2030, the change in the number of inhabitants and the change in the living standard of the citizens were considered. The projection of the increase in waste collection rate from the current 86.4% to 100% was also considered. The data given in the Figure 1, obtained through modelling, show the projected quantities of waste in Serbia for the observed period.

The increase in generated quantities is approximately 15% (Jamison et al., 2014).

Also, based on the model, it is predicted that in 2030 the percentage of paper and cardboard in waste will reach the values of 14%, plastic 13.8%, glass 5.3% and metal 6.7%, while all remaining waste categories together will have a total share of 25.5% (WMP, 2022).



**Figure 1.** Projected amount of packaging waste placed on the market for Serbia from 2014 to 2030 (t/year) (WMP, 2022)

For the purposes of calculating the amount of packaging waste that needs to be recycled and reused in order to meet the defined goals in the future, data on the amount and composition of waste obtained using

the model were used. Based on these data, an increase in the amount of packaging placed on the market in 2030 is expected to be 534,285 tonnes (Figure 1) (WMP, 2022).

According to the National waste management strategy for 2010-2019, 27 waste management regions are planned (WMS, 2010). Each of these regions will have a material recovery facility, so that recyclable waste can be separated into specific fractions for further processing. It is expected that this will also increase the number of employees in waste recovery facilities.

Due to the fact that the number of waste management facilities and their employees will increase, more attention should be given to health and safety measures. Waste workers have high rates of injuries and illnesses, and their fatality rates are higher than those of policemen or firefighters (Jamison et al., 2014). High accident rates are characteristic of the waste management sector; at material recovery facilities, there is a high frequency of injuries and minor injuries, and workers frequently report accidents, injuries, and pain related to ergonomic hazards (Rodrigues et al., 2020).

Workplaces in the waste management sector are exposed to a wide range of risks, which include manual handling, vibration and noise, chemical and biological substances, mechanical hazards, working postures, and work organization (Van den Broek, 2016).

Health and safety risk can be related to:

- the nature of the waste (chemical and biological risks);
- the work process (noise, vibration, risk of falls, cuts, musculoskeletal disorders);
- the work organisation (due to traffic, diverse simultaneous activities, workload difficult to plan in advance, etc.) (Van den Broek, 2016).

The issue of health and safety needs to be set as a high priority in this high-risk industry. In order to mitigate risks and hazards, continuous work in this field is necessary (Jamison et al., 2014).

## **OCCUPATIONAL SAFETY RISK ASSESSMENT AND MODEL DEVELOPMENT**

PUC Čistoća from Novi Sad participated in this research. For the job position *waste separation line operator*, the following risks have been recognized:

- Exposure to sharp objects;
- Moving parts of equipment and vehicles;
- Risk of baled waste;
- Respiratory hazards – presence of dust and pollutants in the air;
- Injuries due to repeated movements (standing for more than 80% of the working day);
- Exposure to chemical and biological hazards;

- Noise and vibration.

Workers in this workplace are always exposed to the risk of mechanical injuries, which may be the result of falling in the workplace, falling on slippery or wet floors or stairs, falling on the belt of a waste sorting line, or falling into a canal or a hole, which can result in fractures, limb injuries, etc.

Line operators are responsible for manual separation of useful waste from the sorting line, so they are exposed to many dangers of mechanical injuries. The rotating belts move slowly, so they do not pose a problem of hands being caught. The danger lies in the composition of the waste on the belt because the operator often cannot find in time what is underneath the top layer of waste, so injuries such as punctures and cuts occur (in contact with a needle on a syringe, sharp pieces of broken glass, etc.). Therefore, parts of the hands and fingers may be caught and injured.

When moving through the hall, i.e., climbing up to the cabin, or moving along the pathways within the waste separation plant, the operators are exposed to the dangers of being run over by vehicles coming from or going to the landfill, to movement of work machines in the hall, or to impact of incorrectly secured bales of separated waste. These risks can result in various transport injuries, such as: light, severe, open, closed, and multiple injuries, injuries to internal organs, and, in the worst-case scenario, fatal injury.

Most of their working time, the operators are exposed to harm from a non-physiological position – prolonged standing and constant leaning over the belt in the waste sorting cabin, which can lead to inflammatory processes of the back and neck, injury to the spinal column, and faster development of degenerative diseases of large joints.

Increased levels of noise and vibrations are created by operation of the engine of the garbage truck that arrives to unload waste in the hall, operation of heavy machinery and forklifts that direct the waste to the belt, and operation of the baling press. The noise and vibrations are also transmitted to the waste sorting cabin where the operators are occasionally exposed, which can lead to nervous tension and increased fatigue.

Employees in a material recovery facility are in direct contact with waste. Syringes are often found in waste and workers are consequently exposed to the risks of biological hazards and hazardous substances (viruses, bacteria, parasites), which can lead to contraction of infectious diseases such as: infectious jaundice, all types of intestinal infectious and parasitic diseases, AIDS, tuberculosis, etc.

The decomposition of organic matter emits unpleasant odours in the hall and in the cabin, which creates a feeling of nausea and other discomforts among employees.

Excessive amounts of dust are created by vehicles, operation of heavy machinery, forklifts, the unloading

of garbage, etc. This dust spreads to a certain extent at the cabin entrance and into the operators' eyes, hair, etc. All this may result in mechanical injuries to the eye, damage to the respiratory organs, etc.

Landfills and material recovery facilities generally represent a breeding ground for insects, rodents, and other animals, with which employees can come into contact during their daily work. This can result in bites, various allergic diseases, and infectious diseases (in the case of rodent bites – cholera, tuberculosis, infectious jaundice, etc.).

PUC Čistoća Novi Sad employs 12 separation line operators. The work is performed in two 7-hour shifts (6 a.m. to 1 p.m. and 1 p.m. to 8 p. m.). The work is done 5 days a week and every second Saturday of the month. During the working day the operators have a half hour break.



**Figure 2.** Waste sorting cabin

The line operators spend their working hours in the sorting cabin, which is located on a raised platform (Figure 2).

Ventilation of the space for waste selection operates on the principle of overpressure, i.e. purified and conditioned overpressurized air enters the sorting cabin, and spent and saturated air leaves the cabin in the hall through purpose-provided openings.

The main components of waste are usually carriers of some species of bacteria that can be emitted in the air in the form of a bioaerosol (Baghani et al., 2022). Direct or indirect contact with the created bioaerosols from the solid waste can spread human diseases. Exposure to such bioaerosols may induce intestinal and infectious diseases of the exposed persons. Genitourinary tract infection, respiratory system infection, pneumonia, allergies, acute toxic effects, diarrhoea, acute toxic allergies, sore throat, and even cancers have been documented among material recovery facility workers (Baghani et al., 2022).

Depending on its pathway, whether through dermal contact, ingestion, or inhalation, there are different severities of exposure to bioaerosols. Severity also depends on the weather conditions, the use of personal protective equipment (PPE), ventilation equipment, type and capacity of the factory, and performed activities (Baghani et al., 2022).

In the light of the above considerations, this paper explores health and safety measures and proposes a

special training course in order to minimize the incidence of injuries.

## RESULTS AND CONCLUSION

According to the information from PUC Čistoća Novi Sad in the observed period from 2004 to 2021, there were no registered cases of injuries at work, occupational diseases, work-related diseases, and disabilities and disorders in the work process that could affect safety and health in the analyzed workplace. Due to this fact, other research results dealing with this issue were analyzed in this section.

According to Jamison (2014), the majority of respondents (70%) in his study reported experiencing some type of injury or illness as a result of their job. The most common injuries reported were musculoskeletal disorders (reported by 57% of the workers) and scrapes and cuts (reported by 43% of the workers), while 60% of the workers expressed their concern about exposure to dust.

Preventive measures can be divided in two groups:

- Health and Safety Training; and
- Safety Equipment.

All the recognized risks and registered injuries warrant an adequate training program. Training should improve the knowledge, skills, and abilities of employees in the waste management sector, in order to increase the expertise, competence, and productivity in the profession within the framework of the already acquired vocational education/qualification, i.e. to increase safety and health at work.

Training participants should acquire knowledge about safe handling of equipment in accordance with the technical regulations and standards, manufacturer's instructions, and regulations in the field of occupational safety and health.

Because of the presence of dust and bioaerosols, indoor air should be controlled by supplying ventilation (mechanical or natural). At all MRFs, workers should be equipped with masks and wearing a mask should be obligatory.



**Figure 3.** Puncture resistant arm sleeves and gloves

Risk of exposure to sharp objects can be minimized with personal protective equipment (puncture resistant gloves) (Figure 3), safety and awareness training, mandatory HBV vaccinations, standard operating procedures (SOPs), supervisors trained in sharps removal, stop line if a sharp is found, trained personnel, and incident medical response plan.

Risk of moving equipment, machinery, and vehicles can be reduced by

- Standard operation procedures; and
- Defining safe zones for foot traffic.

Repetitive movement injuries can be reduced by proper ergonomics of the workplace (Figure 4). Height adjustment on individual pick stations, anti-fatigue standing mats for work stations, limiting reach across belts – using tools as needed, rotation of high pick count stations, and safety training and awareness of potential injuries are some of the solutions.

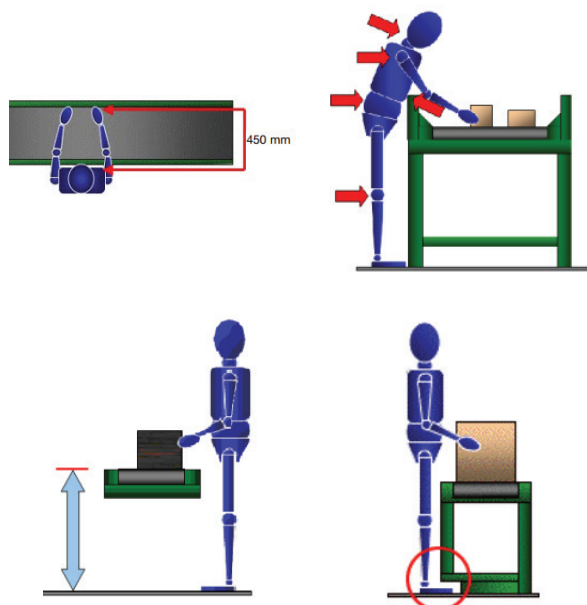


Figure 4. Ergonomics (hse.gov.uk)

## RECOMMENDATIONS

The particularities of jobs in the waste management sector demonstrate the need for special training that will be tailored specifically for employees in this sector.

Through training, workers would get to know the specifics of their workplace, but they would also receive adequate information on how to perform their tasks and duties in the most efficient way possible, without endangering their health and safety. Below are some of the segments that would be incorporated into the training and also be presented to the management of material recovery facilities:

- 1) Continuous development and implementation of engineered solutions for minimization of dust, for ventilation, and for misting.
- 2) Training and information for workers: employees are required to receive training for all the hazards they are exposed to. They should also have access to Material Safety Data Sheets and specific training about the health hazards and preventive measures regarding any toxic substances they may be exposed to, as many workers expressed concern about possible exposures in the workplace and not all were aware that they should

have access to information about all hazards present. The training and information, including that related to dust exposure, has to be provided for all employees (Jamison et al., 2014).

3) Policy: Strengthening national exposure limits, specifically for dust. Employers are constantly exposed to dust, and they are concerned about dust levels and symptoms related to excessive dust exposure. Therefore, it is necessary to examine the permissible limits. It is possible that other discrepancies in the permissible limits for other chemicals are present as well.

## REFERENCES

- Baghani, A.N., Golbaz, S., Ebrahimzadeh, G., Guzman, M.I., Delikhooon, M., Rastani, M.J., Barkhordari, A. and Nabizadeh, R., 2022. Characteristics and assessing biological risks of airborne bacteria in waste sorting plant. *Ecotoxicology and Environmental Safety*, 232, p.113272.  
<https://www.hse.gov.uk/waste/processing.htm>
- Jamison, J., 2014. *Risks and Hazards for Recycling and Waste Workers in the Bay Area*. Tufts University.
- Rodrigues, M.A., Sá, A., Masi, D., Oliveira, A., Boustras, G., Leka, S. and Guldenmund, F., 2020. Occupational Health & Safety (OHS) management practices in micro-and small-sized enterprises: The case of the Portuguese waste management sector. *Safety science*, 129, p.104794.
- The Waste Management Strategy of the Republic of Serbia 2010-2019 (Official Gazette of RS, no. 29/10)
- Van den Broek, K., 2016. Accidents and injuries in the waste management sector. OSHwiki Netw Knowl [Internet].
- Waste Management Program of the Republic of Serbia for the 2022–2031 period

## ACKNOWLEDGEMENTS

The activities were implemented within the global program "Migration for Development" (MFD) implemented in Serbia by Deutsche Gesellschaft für Internationale Zusammenarbeit GmbH (GIZ). The program is part of a broader initiative "Back to New Opportunities", by the German Federal Ministry for Economic Cooperation and Development.

## BIOGRAPHY of the first author

**Miodrag Živančev** was born in Novi Sad, Serbia, in 1983. He received his MSc degree in 2008 and started his PhD studies in 2010, all at the Faculty of Technical Sciences in Novi Sad. He is currently working as a teaching assistant at the Department of Environmental Engineering and Occupational Safety and Health at the Faculty of Technical Sciences, University of Novi Sad (Serbia). His fields of research include design and development of waste management systems, design of landfills, landfill gas utilization systems, landfill closure and remediation, MSW collection systems, and biowaste treatment.





ALEKSANDRA ILIĆ  
PETKOVIĆ<sup>1</sup>

<sup>1</sup>University of Niš,  
Faculty of Occupational Safety

<sup>1</sup>aleksandra.ilic@znrfak.ni.ac.rs

## THE IMPACT OF DIGITALIZATION ON NEW FORMS OF WORK AND PROTECTION OF EMPLOYEES

**Abstract:** *The development of information technology and digitalization during the last decades has led to significant, even radical, changes in the business world. The unstoppable global trend of "digitalization of work" has caused the emergence of new forms of work such as telework, agile work, Crowd Employment, etc. These circumstances require the adjustment and flexibility of employers, employees and the state. Work on digital labor platforms provides workers the opportunity to work from any place, at any time and take up whatever jobs suit them. In addition to this, it has many other advantages. However, there are also some risks from engaging in such work - status of employment, adequate income, and social protection. Labor and protective legislation should be prepared for these changes and react to them in a timely manner. Otherwise, a large number of employees will lose their jobs, or stay without adequate occupational safety.*

**Key words:** digitalization, new forms of work, risks, occupational safety.

### INTRODUCTION

The development of information technology in modern times has led to great changes in people's lives, which have also affected the business world. The coronavirus pandemic has largely contributed to this trend, including the transition to some forms of digital work, which was utilized by many organizations where workers became digital employees.

The past few decades were marked by the spread of information and communication technology to all areas of life and work. This process started with the mass use of computers in the 1990s, and the trend continued with the use of the Internet, mobile phones, laptops, tablets, etc. All this was preceded by the use of robots in industry, which was only intensified over time (Jašarević, 2016).

Under the influence of developing information technology, the conditions in which work is carried out have significantly changed in recent times, including radical changes in labor relations in some fields. Moreover, some authors state that the modern economy is the digital economy and the new society is digital capitalism (Božičić, 2021). Therefore, it is obvious that nowadays we are witnessing the digitalization of work as an unstoppable trend.

The impact of digitalization on work conditions is much greater than it can be seen at first glance. On the one hand, it can significantly facilitate work. On the other hand, it can also be a source of increased exploitation, new higher work norms and collapsed

work standards. The approach that the state and employers adopt to digitalization will affect the position of employees. Also, employees themselves are advised not to take a passive role regarding their potentially changed rights. Trade unions can also play a significant role.

Digitalization has a positive effect on the organization of work and mobility. New forms of work are being created and new possibilities are arising. For example, more employees can share one job (job sharing) or they can work in groups (through "platforms" – the so-called job platformization). Other forms of work resulting from digitalization include telework, agile work and crowd employment. There are also some types of jobs that can be performed using only a smartphone. This is supported by the data on the number of employees on Facebook and Google. According to the data from 2016, Facebook and Google had 12,000 and 57,100 employees, respectively (Jašarević, 2016). To date, these numbers have multiplied, so there are nearly 60,000 people working in Facebook today. Moreover, there were 7 employees in Facebook in 2004 and 58604 in 2020 (FinancesOnline, Research Center, 2022).

Despite numerous advantages, these new forms of work have led to the emergence of new work-related risks - electromagnetic radiation (from mobile phones), insufficient movement due to excessive computer use (which causes various musculoskeletal, heart and mental disorders), risks in traffic (drivers using mobile phones), burnout syndrome, etc. These risks should be

taken into consideration when carrying out the risk assessment in the workplace and work environment and preparing the risk assessment act.

## **PAPER LAYOUT SOME NEW FORMS OF WORK AND EMPLOYEE PROTECTION**

### **Telework**

Telework was the first form of work to emerge from digitalization. In 2002, it was regulated by the European Framework Agreement on Telework in the European Union (Framework Agreement on Telework, 2002). According to this agreement, remote work is a form of organizing and performing work using information technology, within the context of an employment contract/relationship, where work, which would normally be performed in the employer's premises, is performed outside these facilities on a regular basis.

In this type of work, employers saw the opportunity for more flexible business and cheaper organization of work. It enables employees to work in a more relaxed atmosphere (from home) and achieve a better work-life balance.

The number of employees who practice this form of work is constantly increasing. In the European Union, it applies to 1-4% of employees as a permanent type of work (up to 9% – in the Czech Republic), and about 5-15% of the workforce spends ¼ of their business hours working remotely (Jašarević, 2016).

The downside of this form of work is the lack of clear boundaries between work and family life, which can lead to employees working longer hours remotely than on site, as work is often blended with private life. Even though teleworking can improve the process of reconciling work and family obligations, it can also blur the line between the two. Unlike work on site which implies specific working hours, teleworking often involves working at night or on weekends and holidays. On the other hand, the increase in working hours is compensated by saving time on daily commutes (Urdarević, 2021).

Telework, on the one hand, enables employee to organize their working hours in a better and more efficient way according to their personal needs. On the other hand, these employees may make more effort but receive the same income as their colleagues who work in the office. With regard to teleworking, work-life balance is the most sensitive issue, but it is also the main reason why employees choose such a form of work.

In the matter of occupational safety and health, there are some specific hazards related to this form of work which can be potentially identified. Among other things, some medical problems, such as neck pain, eye and finger fatigue and the like, can be caused by inadequate work equipment. Also, social isolation, lack of social interaction, constant availability to employers

and co-workers and so on, are some additional issues that should be specially treated.

### **Agile work/ICT-based mobile work**

Agile work originated as a form of work owing to cheaper information technology and computer equipment, expansion of the Internet, development of mobile telephony, acceleration of computer operation, etc. In this type of work, employees can work from home, public transport, rented space and any other place. This applies to both part-time and full-time work.

Although at first glance agile work seems similar to telework, there are significant differences. Teleworkers work from one place and alone, whereas agile workers work from multiple locations and interaction with others. Because of this difference, mobile workers are considered agile, productive, and motivated.

Agile work is a growing trend. For example, in CISCO, 90% of employees work outside the company at least one day a week, and 32% work remotely all the time. In Accenture, workers can work from any place two days a week. In GM Powertrain, employees can choose their location of working ten days a year. In Unicredit, employees have the right to choose their place of work one day a week (Božičić, 2021). In the Netherlands, this type of work is particularly present among the more educated employees, so that 1/3 of them have the right to work from home at least one day a week. In the United States, at least 30 million people work at least once a week from home, and 3 million people never go to the office. Also, 70% of employees work from alternative locations on a regular basis (Jašarević, 2016).

Considering occupational safety and health, the positive and negative sides of this form of work are similar to those of teleworking. In the literature, autonomy and flexibility of workers are emphasized as a particular advantage which enables better work-life balance of employees.

### **Crowd Employment**

Crowd employment is one of the biggest novelties in the business world resulting from digital technology. It is mostly used in the service sector or creative industries. It is based on virtual “platforms” that organize the mass work of people worldwide gathered around a particular task, project, product or service. Digital platforms are a kind of market where two or more different interdependent parties “meet” and where at least one party yields benefits from such a relationship. This “encounter” takes place on the Internet (UK House of Lords, 2016).

The digital platform for performing such work is an internet service, or an application, which is accessed by the entities that have the need for the performance of certain work and entities that can do the necessary work, i.e. those that have the need to find a job (digital

workers). The fact that these are online platforms makes them operate as virtual labour markets. This means that platforms can be accessed at any time and from any part of the world if there is access to the Internet.

Work is performed for a user or client, whom a digital worker has no contact with. Clients ("user-employers") have no direct relationship or legal relationship with the employee. Instead, the platform is the so-called employer which pays these "virtual workers". Employers are "crowdsourcers" - "mass users", for whom "mass workers" - "crowdworkers" perform certain jobs. The whole process is managed through "mass platforms" - "crowdsourcing platforms" (Jašarević, 2015).

On the basis of the features of such work, we can observe that these platforms provide an unlimited network of people ready to carry out the necessary task at any time for a certain compensation. This is why it is called crowd employment or crowdwork (Eurofound, 2015).

One of the most famous examples of platform work is working for Amazon as the largest digital trading platform and one of the largest digital platforms ever. The number of digital workers on the Amazon platform continues to grow, and similar platforms have started to appear in other industries. Nowadays, there are approximately 800 active digital platforms, and the exact number of digital workers using these platforms cannot be accurately estimated (ILO, 2021).

A good aspect of this type of work is that people can make some profit if they are unemployed, make extra income or gradually gain professional experience. The downside is the instability of income and work and the absence of any control over the employer-employee relationship. In general, the common characteristic of this and other new forms of work with the help of digital technology is that they are mostly legally unregulated. Therefore, workers are usually not registered and do not have legal protection equivalent to employees who enter an employment relationship. Also, they usually do not enjoy social insurance.

## CONCLUSION

Digitalization in the business world has both positive and negative sides. With regard to its benefits, it accelerates and facilitates employees' work and increases their productivity. As a result, the employer's profits increase. This is understandable when considering that a single hard drive or cloud technology can contain the data that used to be printed on a multitude of papers, or that huge machines and factory halls could be replaced by a single robot. Another advantage is the fact that new positions are being created for this type of work.

Also, we are witnessing an increase in the production volume of information technology equipment, the scope of jobs related to smartphone applications and

computer programs and so on. There is a change of the location of work as jobs are no longer predominantly performed in the employer's premises, but remotely using Internet platforms, web meetings, emails, etc. Moreover, we can also observe the emergence of the "decentralization of work", or "dematerialization of business processes and employers" (Jašarević, 2016). In such cases, typical enterprises and companies do not exist and the work takes place either in several places or via the Internet. Such employees are called 'e-nomads', or 'invisible workers' (Houwerzijl, 2015).

Another benefit of the digitalization of work is its contribution to establishing work-life balance (it enables work from home, during travel, and flexible working hours). Commuting expenses, traffic congestion and pollution are decreased due to reduced daily commutes. All these advantages lead to an increase in productivity and employer's profits.

However, digitalization of work also has some obvious flaws. The first issue concerns the ratio of the number of new digital positions and the number of people who lost their jobs due to digitalization. The number of new jobs still appears to be significantly lower than the jobs that are disappearing. Also, many workers are considered self-employed when working in the employer's premises and as part of a work organization, but without an employment status.

For all these reasons, we can conclude that the definition of employers and employees should be revised in the contemporary world. There is a need for more precise regulation of the employment relationship, rights and obligations of employees and employers and their occupational safety and health. It is necessary to introduce a more flexible employment status, which will enable employers and employees to regulate their relationships with a greater degree of independence. This implies the introduction of new forms of work, such as agile or mobile work, into our legal system. These changes in labour legislation would also require some modification in the legal regulation of occupational safety and health. No innovation in the legislation should be detrimental to the safety and health of workers, even if it brings higher profits. All this points to the need to revise the Law on Occupational Safety and Health (2005) in order to recognize new forms of work and provide workers with adequate legal protection against work-related injuries and occupational illnesses that may arise from digitalization.

## REFERENCES

- Božičić, D. (2021). *Ostvarivanje i zaštita prava na rad u digitalnoj ekonomiji* (doktorska disertacija). Novi Sad: Pravni fakultet.
- Eurofound (2015). *New forms of employment*. Luxembourg: Publications Office of the European Union.

Houwerzijl, M. (2015). Digitalization and Mobility of EU-Workers/Services. In: European Labour Law Network – 8 th Annual legal seminar Digitalisation and Labour Law (pp. 1-12). Hague.

FinancesOnline, Research Center (2022). Number of Facebook Employees 2022/2023: Compensation, Tenure & Perks [online], available: <https://financesonline.com/number-of-facebook-employees/> [Accessed 24 August 2022].

Framework agreement on telework [online], available: <https://www.worker-participation.eu/EU-Social-Dialogue/Interprofessional-ESD/Outcomes/Framework-agreements/Framework-agreement-on-telework-2002> [Accessed 5 August 2022].

ILO, The role of digital labour platforms in transforming the world of work, World Employment and Social Outlook, Geneva, 2021.

Jašarević, S. (2016). Uticaj digitalizacije na radne odnose. Zbornik radova Pravnog fakulteta u Novom Sadu, 4, str. 1103–1117.

Jašarević, S. (2015). Nove forme rada u Evropskoj uniji. U: Harmonizacija srpskog i mađarskog prava sa pravom Evropske unije: Tematski zbornik, Knjiga 3, (str. 281-298). Novi Sad: Pravni fakultet.

The Law on Occupational Safety and Health, „Official Gazette of Republic of Serbia“, No. 101/2005, 91/2015, 113/2017.

UK House of Lords (2016). Online Platforms and the Digital Single Market, Chapter 3: Defining ‘online platforms’ [online], available:

<https://publications.parliament.uk/pa/ld201516/ldselect/ldsecom/129/12913.htm> [Accessed 20 August 2022].

Urdarević, B. (2021). Rad na daljinu kao specifičan način organizacije rada. Zbornik radova Pravnog fakulteta u Novom Sadu, 1, crp. 205–221.

## ACKNOWLEDGEMENTS

This research was funded by the Ministry of Education, Science and Technological Development of the Republic of Serbia, Contract on the realization and financing of scientific research work of the scientific research organization in 2022 number 451-03-68/2022-14/ 200148.

## BIOGRAPHY of the first author

**Aleksandra Ilić Petković** is an Associate Professor at the Faculty of Occupational Safety, University of Niš, Republic of Serbia. She graduated from the Faculty of Law, University of Niš and obtained her Ph.D. degree at the Faculty of Law, Public Administration and Security of the Megatrend University in Belgrade. While studying social problems of occupational safety and environmental protection with special emphasis on the legal regulation of this issue, she has published a number of scientific papers on this subject.



TATIANA IVANOVA <sup>1</sup>  
IRINA KOLODIY <sup>2</sup>

<sup>1,2</sup> University of Ulyanovsk,  
Faculty of Management

<sup>1</sup> [tivanova.j@gmail.com](mailto:tivanova.j@gmail.com)

<sup>2</sup> [irina\\_kolodiy@list.ru](mailto:irina_kolodiy@list.ru)

## EMOTIONAL BURNOUT AS THE MAIN FACTOR OF OCCUPATIONAL SAFETY IN MODERN CONDITIONS

**Abstract:** *During the epidemic of a new coronavirus infection, the requirements for the professionalism of employees with completely different specialties have increased, due to the difficult economic situation in the world. Widespread cuts due to the bankruptcy of small companies and private businesses, as well as the increased burden on medical personnel, have led to the fact that constant stressful conditions and an emotionally unstable situation have become a common companion for humanity. Not everyone can easily adapt to such increased requirements in their professional activities. Effective performance of one's social role in some cases becomes difficult. In such conditions, the likelihood of developing social stress disorders, including emotional burnout, increases.*

*There is a problem of personal stress resistance in various professional spheres. There are a number of professions in which a person is particularly susceptible to emotional burnout. And these are exactly the professions where you have to constantly interact with other people, and there there is the unpredictability of results. Therefore, a person often feels stressed.*

**Key words:** emotional burnout, personal stress resistance, occupational safety

## INTRODUCTION

The rapidly changing business environment is becoming increasingly incomprehensible, fragile, and alarming, and people sometimes do not know what changes they may expect tomorrow. These factors negatively affect their emotional state. Under the influence of difficult working conditions, the likelihood of emotional burnout of employees increases significantly.

It should be expected that in the current conditions of the COVID-19 pandemic, most workers are more or less susceptible to professional burnout; therefore, it is important to take preventive measures to prevent and eliminate this syndrome.

## METHODS

The theoretical methods used in this paper include the analysis, systematization and generalization of data, and the empirical method as a testing method that includes the use of a method for diagnosing the level of emotional burnout.

## LITERATURE REVIEW

It is fair to say that the pandemic of the new coronavirus infection COVID-19 has changed the habitual way of life of all mankind for the foreseeable future. The world has undergone tremendous changes

in the social, economic, political and spiritual spheres. Quarantine measures, lockdown, tense situation in society, daily fear for one's own life and the health of loved ones, crisis, self-isolation, switching to remote work, uncertainty of the future and fear of the present are only some of the factors that have already become a reality for modern man and have repeatedly increased the stress level of society as a whole.

The new world demanded new rules of the game and new laws, thanks to which it would be possible to revitalize the existence of mankind.

Many authors attempted to describe the economic and business environment over the past decades. In order to trace how the conditions of existence for all mankind have changed, it is necessary to look at history.

In the works of many researchers, one can find references to the SPOD world (Artamonova M., 2019).

The acronym "SPOD" characterized the old, stable and predictable world that existed before the mass spread of computing and the Internet:

- Steady (stable)
- Predictable (predictable)
- Ordinary (simple)
- Definite (defined)

Economic agents have developed SPOD strategies, the application of which was always predictable and led to



planned results. But the era ended when the development of technology began to outpace the change of one generation.

It was replaced by the VUCA-world. The concept of VUCA appeared in the bowels of the US Army Military College in the late 1980s, from where it quickly spread among the military leadership in the 1990s, and by the early 2000s began to appear in business strategy books. This is a formulation illustrating a world that emerged in an increasingly networked, highly digital environment after the Cold War (Cascio, 2020).

V – Volatility;  
U – Uncertainty;  
C – Complexity;  
A – Ambiguity.

Over the past two decades, these words have become familiar concepts among people. The VUCA paradigm helped companies develop new flexible strategies and business models and better understand their customers and competitors. In 2007, the VUCA Prime model appeared, and in 2008, when the global financial crisis was marked by the bankruptcy of the Lehman Brothers, the VUCA concept gained recognition as contributing to informed decision-making in a destabilizing environment.

However, at the moment, in order to illustrate the scale of the ongoing changes and chaos that have arisen with the arrival of the COVID-19 pandemic and to better understand the external environment, it is necessary to accept the fact that the VUCA world has come to an end.

BANI-world is an acronym for describing the new reality, its mechanisms, and conditions of existence. It was proposed by the futurologist Jamais Cascio – one of the world's leading thinkers according to the American journal of International Policy and the creator of the online resource "Open the Future", who first presented his theory at the Institute of the Future (IFTF), California (Cascio, 2020).

BANI describes the current (pandemic and post-pandemic) world:

B – Brittle;  
A – Anxious;  
N – Nonlinear;  
I – Incomprehensible.

BANI describes a world in which conditions are not just unstable, but chaotic, and the results are not only difficult to predict, but are also completely unpredictable. So many shocking events happening now are unfamiliar, unexpected, and completely disorienting. The changes taking place in society not only increase the stress that society is experiencing, but also multiply it by many times. A person is a reflection of the external environment, an integral part of it, and in order to better understand how the world and the

person in it have changed, it is necessary to analyze each component of the acronym in more detail.

**B – Brittleness.** As Jamais Cascio (2020) himself wrote: "Brittleness is an illusory power." A fragile system can outwardly seem very reliable and durable until it breaks down due to a single critical reason. In the context of the external environment, people are susceptible to disasters at any time. For example, the restaurant business seemed unshakable, but with the arrival of the pandemic, it became fragile and many companies were on the verge of shutting down. Even energy networks and global trade have become "brittle", even though these are fundamental systems on which human survival depends. The same can be said about employees specializing, for example, only in the service sector, which turned out to be particularly fragile in the context of a pandemic. According to the International Labour Organization (ILO), in January-March 2020, before the start of self-isolation, the number of unemployed persons in Russia was 3.5 million (4.7% of the workforce). In April, according to Rosstat, unemployment was 4.3 million (5.8%), and in May 4.5 million (6.1%) (Gimpelson, 2020). The fear of losing a job repeatedly increases employee stress.

**A – Anxiety.** Stress and anxiety are a chronic condition of the society of the 21<sup>st</sup> century (to assess the extent of its prevalence, it is worth noting that WHO has removed stress as a risk factor for cardiovascular diseases, since it is ubiquitous and unmodified). New restrictive measures, a new mode of operation, a new wave of coronavirus, new mutated strains, voluntary-compulsory vaccination, contradictory points of view – all this is often exacerbated by false media reports. The need to be aware of events in order to make the right choice leads to even greater disorientation and misinformation, repeatedly increasing anxiety and uncertainty in trying to distinguish lies from the truth. The need to control the situation turns into the realization that environmental control is impossible. Society is in a state of depression and fear. Any choice seems potentially disastrous.

**N – Non-linearity.** Cause and effect seem unrelated. The results of the decisions taken are unbalanced. Small actions lead to colossal consequences, and huge efforts lead to negligible results.

The difference between the scale at which things happen and the scale at which each individual perceives them is huge. The scale and scope of the pandemic goes far beyond everyday experience: the speed with which the infection spread around the world was staggering. The inertia of the surrounding world represents a lag between the cause and the full effect. The virus forced most of the population to abandon social contacts and to be afraid of these very contacts, which turned out to be disastrous for giant business models and gave impetus to the development of small start-ups.

Climate disruption is another non-linear problem. What society is witnessing now is primarily the result of carbon emissions in the 1970s and 1980s. The global climate system has enormous inertia, and the consequences do not manifest themselves immediately.

The effectiveness of vaccination also has a highly non-linear aspect, which an individual may not always realize.

**I – Incomprehensibility.** Information overload leads to incomprehensibility. Additional information is no longer a guarantee of better understanding. On the contrary, excessive awareness can be counterproductive, suppressing the human ability to understand the world. This trait is also inherent in artificial intelligence systems, which are beginning to be actively introduced into the life of society and become more and more complicated, so that even their creators find it more difficult to understand how they reach a decision.

An important factor is the psychological state of society during the pandemic. According to the study of neurologists of the Ulyanovsk region, the following conclusions were made. Regarding the neurological disorders in patients with a confirmed diagnosis of COVID-19 at the prehospital stage:

- 76.7% suffered from anxiety;
- 93.3% suffered from depression;
- Women were characterized by pronounced manifestations of clinical depression and anxiety at the same time (85.7%);
- Men were characterized by pronounced depression (88.8%) (Nikishin et al., 2021)

According to the Lancet Psychiatry research, 20% of patients with COVID-19 developed mental health problems within three months after diagnosis – disorders such as depression, anxiety or dementia appeared. The risk of these disorders was twice as high compared to people who did not have COVID-19.

Thus, humanity is faced with a completely new, chaotic, and incomprehensible world in which any decision can potentially lead to disastrous results. Uncertainty about the future repeatedly increases stress and anxiety. Against the background of COVID-19 infection in the context of post-COVID syndrome, the risk of anxiety and depression also increases. Together, all these factors have a negative effect on people, burning out their strength for adequate professional activity and exhausting their emotions, while their personal achievements fade against the background of grief from losses, fear of death and awareness of the meaninglessness of existence.

## RESULTS AND DISCUSSION

A study of emotional burnout of employees of the planning and economic department of one company was conducted through testing. To study the emotional

state and identify emotional burnout among employees, the "Burnout Questionnaire (MBI)" by K. Maslach and S. Jackson, adapted by N. E. Vodopyanova, was used, since it is currently considered the gold standard for diagnosing the level of emotional burnout. According to K. Maslach and S. Jackson's three-component model, "burnout" is understood as a syndrome consisting of the following components:

- Emotional exhaustion is the main component of "burnout", manifested in a reduced emotional background, indifference or emotional oversaturation.
- Depersonalization is a manifestation of deformation in relationships with people. Increased dependence on others or negativism, cynicism of feelings towards recipients (patients, clients, subordinates).
- Reduction of personal achievements – a tendency to negatively evaluate oneself and one's own professional successes, negativism regarding official merits, reduction of one's own dignity, limitation of opportunities or responsibilities towards others.

To clarify the stage and progression of emotional burnout, the test "Diagnostics of the level of emotional burnout" by V. V. Boyko was used. During the study, 10 employees of the company's planning and economic department (7 women and 3 men) were interviewed, whose main activity is direct interaction with customers. Testing was carried out in electronic format using the platform psytests.org. (The testing of this platform was carried out on their own experience by comparing the results of the answers calculated manually and automatically). Before testing, a briefing was conducted on the answers to the test questions, after which the respondents answered the questions by filling out the test themselves.

According to the results of the study, the following was revealed:

- 20% of the respondents (2 people) are highly susceptible to emotional burnout and have a high level of burnout in all three parameters;
- 30% of the respondents (3 people) have a low burnout level in all three parameters;
- 20% (2 people) of the respondents have a high level of burnout on one scale, namely, *reduction of personal achievements*, and at the same time a moderate or low level of burnout for *depersonalization* and *emotional exhaustion*, which is most likely due to a lack of work experience and low self-esteem of these employees;
- 30% of the respondents are not strongly susceptible to emotional burnout and have a moderate level of burnout in all three parameters.

It can be concluded that most employees are subject to emotional burnout at a moderate level. This situation is

not critical; however, attention should be paid to the condition of the working staff.

According to the results of a survey conducted according to the methodology of V. V. Boyko, the levels of formation of all three phases of emotional burnout in individual employees are as follows:

- None of the phases are formed in 3 people (30%);
- 1-2 phases are in the stage of formation in 4 people (40%);
- 1-2 phases are fully formed in 2 people (20%);
- All three phases are fully formed in 1 person (10%).

Thus, according to the test results, 30% of the respondents are not subject to emotional burnout, since they do not have a single formed phase, which correlates with the MBI test results.

Forty per cent of the employees are at the formation phases of emotional burnout and are already experiencing the corresponding symptoms.

Thirty per cent of the respondents are highly susceptible to emotional burnout. At the same time, 2 employees have fully formed 1-2 burnout phases, and 1 employee has formed all three phases of emotional burnout.

In addition, it is necessary to distinguish the levels of formation of each of the burnout phases in the whole group (Table 1).

**Table 1.** *The level of formation of burnout phases in the study group*

	Stress phase	Resistance phase	Exhaustion phase
The phase is not formed	3 people (30%)	5 people (50%)	6 people (60%)
The phase is formed	4 people (40%)	3 people (30%)	3 people (30%)
The phase is formed	3 people (30%)	2 people (20%)	1 person (10%)

The table shows that the third phase of emotional burnout – the exhaustion phase is the least frequently formed in this group. In its formation stage, it was detected in 30% of the respondents, while it was fully formed in 10% of the employees. For the majority of this group (6 people), the exhaustion phase was not formed, that is, during the performance of their professional activities, most of the employees, respond adequately to certain stressful situations and there is no decrease in emotional tone.

Stress phase is the most frequently formed phase in the group of employees of the planning and economic department, and it is a harbinger and a triggering mechanism in the formation of emotional burnout. Almost a half of the surveyed employees are at the formation stage of this phase (40% or 4 people), while 30% of the respondents are in already formed stress phase (3 people). The data obtained allow us to

conclude that 7 employees, or more than a half of the study group, are already experiencing anxiety tension, whereby their level of dissatisfaction with themselves increases and they exhibit signs of anxiety and depression.

Nevertheless, 3 people (30% of the respondents) did not have symptoms of the formation of the anxiety tension phase, which means that this group of employees feels psychologically comfortable in the workplace and during the performance of their activities.

The resistance phase, in which a person experiences emotional and psychological discomfort and actively resists it, trying to reduce the pressure of external and internal factors contributing to emotional burnout, is fully formed in 20% of the respondents (2 people), and is at the stage of formation in 30% of the respondents (3 people). At the same time, a half (50%) of the employees have not formed this phase.

Based on the results of surveys conducted using the two methods, most employees are partly susceptible to emotional burnout. About 20-30% of the employees have a high level of emotional burnout, which is a serious problem both for the employees themselves and for the department as a whole.

Most likely, this is due to the difficult situation in the world at the moment.

Nowadays, it is very important to pay attention to the staff, their professionalism and emotional state, especially in turbulent times against the background of the COVID-19 pandemic.

There is a need for careful consideration and selection of currently available tools to combat burnout syndrome (in 30% of employees), as well as for its prevention in those workers whose syndrome is at the stage of formation or has not yet formed.

Prevention of professional burnout of employees is an important aspect of activity in the organization, contributing to the prevention of the syndrome. If employees have already faced the problem of burnout, it is necessary to take measures to eliminate this phenomenon as soon as possible.

## CONCLUSIONS

First of all, it is necessary to regularly diagnose the state of burnout in a team. Annual diagnosis of the syndrome and planning of subsequent individual corrective work with employees will prevent the occurrence or repel the already formed symptoms of emotional burnout.

Second, the hitherto new and unknown environment – the pandemic world – has a negative impact. The BANI structure offers a prism through which one can see and structure what is happening in the world. The components of the abbreviation may hint at opportunities for counteraction:

- Brittleness can be met with flexibility;
- Anxiety can be relieved by empathy and mindfulness;
- Non-linearity will require expanding the circle of causal relationships;
- Incomprehensibility can reduce the transparency, clarity and reliability of the information environment.

It is also important that the BANI-world gives a name and characterization to the fear and difficulties that many employees are experiencing right now. Understanding and awareness is the first step for the adoption and development of response methods to counteract the adverse environment.

The BANI-world declares that what we see is not a temporary deviation, but a new phase to which it is necessary to adapt. Unfortunately, an individual or even a group of people is not able to completely eliminate its negative influences, but it is able to offer some resistance.

## REFERENCES

Artamonova. M. V. (2019). *Competence approach in personnel management of a modern organization in the digital economy. Human and industrial potential of the Russian economy before global and local challenges* (Materials of the II All-Russian Scientific and Practical Conference), Saratov, pp. 56-57

Cascio J. (2022). *Face to face with the era of chaos*, Medium, [online], available:

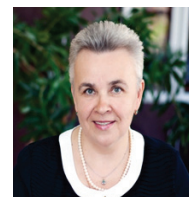
<https://medium.com/@cascio/facing-the-age-of-chaos-b00687b1f51d> - [Accessed 15 Jan 2022].

Gimpelson V. (2020). *Work in quarantine: how the pandemic affected estimates of Russian unemployment*, RBC, [online], available: <https://www.rbc.ru/opinions/economics/23/06/2020/5ef06fet9a79478939a1e832> -[Accessed 16 Jan 2022].

Nikishin K. E., Lyalchenko Yu. A., Mashin V. V., Belova L. A. (2021). *General neurological disorders in patients with a new coronavirus infection COVID-19*, Translational medicine. No. 3, pp. 73-74.

## BIOGRAPHY of the first author

**Tatiana Ivanova** was born in the Smolensk Region, Russia, in 1959. She received a diploma in economics and a PhD in management from St. Petersburg State University.



Her main research areas include management under uncertainty and digital transformation of management. She currently works as the head of the Department of Management at Ulyanovsk State University.





ANA SILVA<sup>1</sup>  
ANDRÉ FILIPE FERREIRA  
DA SILVA<sup>2</sup>  
RAQUEL PEREIRA  
MARTINS<sup>3</sup>  
OLÍVIA PINHO<sup>4</sup>

<sup>1,2,3</sup>University of Porto,  
Faculty of Engineering

<sup>4</sup>University of Porto,  
Faculty of Nutrition and Food  
Science

<sup>4</sup>University of Porto,  
LAQV-REQUIMTE

<sup>1</sup>up201708869@up.pt

<sup>2</sup>andrefilipe\_sf@hotmail.com

<sup>3</sup>rpmar@fe.up.pt

<sup>4</sup>oliviapinho@fcna.up.pt

## SICK BUILDING SYNDROME (SBS) IN HEALTHCARE WORKERS: A SYSTEMATIC REVIEW OF INTERVENTIONS

**Abstract:** Indoor air quality (IAQ) is a health concern in healthcare buildings that receive workers and susceptible patients. Sick building syndrome (SBS) is a collection of non-specific symptoms caused by exposure to harmful agents associated with the occupancy of certain buildings. This review aims to provide an overview of the most recent literature on SBS and Build-Related Illness (BRI) studies performed in healthcare units and to identify the tools applied to characterise the SBS or BRI in healthcare units. After applying the PRISMA Statement, 13 articles were considered relevant to this research. The most used questionnaire was the MM 040 NA. By comparing the self-assessment results and measurements of environmental parameters, it was identified the same risk factors, proving consistency of the results. Each IAQ parameter influences several categories of SBS symptoms, so when conducting a study in this field, it is important to include a broad range of air quality parameters. The findings also demonstrated the need to develop further studies in this area in Portuguese healthcare units.

**Keywords:** Indoor Air Quality, Healthcare Worker, Sick Building Syndrome, Building-related Illness, Occupational Health

## INTRODUCTION

**Indoor air quality (IAQ)** is a significant health concern, especially in healthcare buildings that receive workers and susceptible populations such as the elderly, patients with chronic respiratory diseases, and immunocompromised patients (Baudet et al., 2022).

**Sick Building Syndrome (SBS)**, as a collection of non-specific symptoms of an illness caused by exposure to harmful agents, is associated with the occupancy of certain workplaces. The most common symptoms of SBS include eye, nose, and throat irritation, dry mucous membranes and dry skin, rash, mental tiredness, headache, frequent upper respiratory tract infection and cough, loss of voice, wheezing, itching and non-specific hypersensitivity, nausea, and dizziness (Babaoglu et al., 2020a; EPA, 1991). In contrast, the term **Build-Related Illness (BRI)** is commonly used when symptoms of diagnosable illness are identified and can be attributed directly to airborne building contaminants (Menziés & Bourbeau, 1997).

The main objective of this review is to provide an overview of the most recent literature on SBS and BRI studies performed in healthcare units, and identify the tools applied to characterise the SBS or BRI in healthcare units.

Proceeding to the systematic review of this topic, the authors formulated the following questions:

1. Which questionnaires or tools are being applied to assess SBS or BRI, and which parameters are evaluated in each method?;
2. Which IAQ or IEQ parameters are being assessed, and which parameters influence SBS symptoms?

## MATERIAL AND METHODS

The systematic literature review was conducted using the Preferred Reporting Items for Systematic Reviews and Meta-Analysis (PRISMA) Statement (Dewey & Drahota, 2016; Page et al., 2021). The following databases were used to develop this research: Scopus, Web of Science, and Science Direct. The research was performed using four groups of relevant search terms. Firstly, to conduct this study, the authors selected the most relevant terms in this field: "indoor air quality", "indoor environmental quality", "IAQ", "IEQ", "Sick building syndrome", "sick building", "building-related illness", "SBS", "BRI", "healthcare", "health care", "hospital", "innovation", "innovative", "engineering", and "technology".

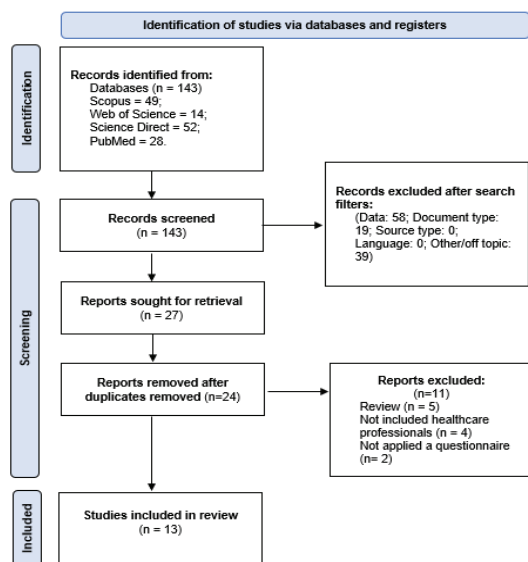
To select the most relevant studies, the authors considered exclusion criteria. Initially, filters were used in each database, limiting the selected studies by date, considering articles between 2010 and 2022.

Relatively to the document type, source type and language, the selected criteria were research articles published in peer-reviewed journals and written in English. Each article was analysed to remove studies not fulfilling the inclusion criteria: 1) only articles with studies performed in healthcare units (Hospitals, clinics, etc.); 2) included healthcare professionals; and 3) applied a questionnaire or an interview or other subjective method to assess the SBS or BRI symptoms.

Finally, additional sources found in citations were consulted. All articles considered in this study were assessed to identify the bias and determine each study's strengths and weaknesses. The IAQ parameters were presented in Table 1, as follows: relative humidity (HR in %), carbon monoxide (CO in ppm), carbon dioxide (CO<sub>2</sub> in ppm), levels of particle matter (PM in ppm), temperature (in °C), noise levels (in dB(A)), illuminance (lx), and classified as follows: evaluation performed - "✓" and evaluation not performed - "✗"

## RESULTS AND DISCUSSION

In the electronic search and PRISMA Statement methodology, initially, 143 articles were retrieved from all databases (Scopus = 49, Web of Science = 14, Science Direct = 52, and PubMed = 28). After concluding this phase, 116 articles were excluded, and three articles were found duplicated, leaving 24 articles for the following phase. Finally, according to the eligibility criteria, 13 articles were considered relevant for this research. **Figure 1** presents the overview of the number of studies from each PRISMA methodology stage.



**Figure 1 - Application of the PRISMA Statement to select articles of this review**

The most used questionnaire was the MM 040 NA Hospital, used by seven authors included in this review (Akova et al., 2022; Arikan et al., 2018; Hoang Quoc et

al., 2020; Kalender-Smajlovic et al., 2021; Kalender-Smajlović et al., 2022; Sayan & Dülger, 2021; Vafaenasab et al., 2014). The survey was adapted to workers who did not have direct contact with patients, creating the MM 040 NA Office, which was applied in two studies (Kalender-Smajlovic et al., 2021; Kalender-Smajlović et al., 2022). The Miljömedicin 040 Questionnaire was used by one author (Jafakesh et al., 2019), and four authors developed their surveys (Babaoglu et al., 2020a; Eijkelenboom et al., 2020; Liu et al., 2018; Tang et al., 2020), based on other methods.

The MM 040 NA form was developed in 1985 to assess IAQ and characterise the effects reported by their occupants living in these environments (Andersson et al., 1988). Another version of this questionnaire is the MM 040 NA Office (Andersson et al., 1990), which was applied to healthcare professionals that did not work directly with patients (Kalender-Smajlović et al., 2022). Both forms include questions about perceived indoor air quality, emerging symptoms, potential relationships with the indoor environment, psychosocial environment, and some basic factors (Akova et al., 2022). These questionnaires were applied with the purpose of establishing an association between self-assessed data by healthcare workers and the IAQ measured parameters. According to one author that conducted several studies included in this review, it was confirmed that a comparison of self-assessment results and measurements of environmental parameters identified the same risk factors (Kalender-Smajlović et al., 2022), proofing consistency of the results. Another study testing the relationship between SBS and Hospital Indoor measurements concluded that the risk of SBS was found to be 1.2 times higher with increases in the measured noise level and 2.1 times higher with increased CO<sub>2</sub> concentrations (Arikan et al., 2018). In another study conducted in the General State Hospital, the risk of SBS decreased 1.69 times with the increase in respirable dust level measured in and, in the Oral and Dental Health Hospital, the risk of SBS decreased 1.01 times with the increase in lighting level measured (Akova et al., 2022). Akova compared the working environment variables with the Total Complaint Score (TCS) – evaluation of each consequence according to the frequency. The mean TCS was positively correlated with gender, educational level, stress level, social relationship, noise level, comfort level, cleanliness, the number of employees in the room, the number of windows, the presence of odour, new wall paint, the presence of rotting/mould, the use of cleaning chemicals in the room and room size (Akova et al., 2022). Three authors only applied the questionnaire and opted not to measure environmental parameters (Kalender-Smajlovic et al., 2021; Sayan & Dülger, 2021; Vafaenasab et al., 2014). One study applied the questionnaire but established the relationship between SBS and the IAQ (Smajlović et al., 2019). About five articles applied subjective measurements, including formulated surveys (Babaoglu et al., 2020a; Eijkelenboom et al., 2020;

Hoang Quoc et al., 2020; Liu et al., 2018; Tang et al., 2020). Another study applied the NMO40A questionnaire based on a pilot search with 20 healthcare workers. The indoor environmental conditions did not explain the SBS among health workers, except for the lightning values. When the lightning increased one lux, the score of SBS increased by 0.01 points (Hoang Quoc et al., 2020). One author retrieved the health, personal components and IEQ subcomponents from the OFFICAIR questionnaire and added the category "noise" (Bluyssen et al., 2016). This survey was designed to obtain more insight into the complaints and building-related symptoms of occupants, considering psychological and health aspects. The study concluded that there was little difference in the prevalence of the main self-reported symptoms. One author developed a survey after conducting a literature review. It included 45 questions and included the following characteristics: age, marital status, educational level and body mass. Additionally, it included the number of years of work, other risk factors, and items about SBS. The study included a correlation between self-assessed SBS symptoms with personal, psychosocial and environmental factors (Babaoglu et al., 2020a). Another study included a questionnaire to collect subjective satisfactory vote and identify the factors that contribute to the satisfactory vote in two hospitals, having the principle that several variables could be clustered into a single variable (Liu et al., 2018). The survey included three components: a) sociodemographic data; b) satisfaction with IEQ parameters in the winter, summer and transition; c) satisfaction with building performance factors (Sadatsafavi et al., 2013; Zagreus et al., 2004). The correlation between this questionnaire and the objective data could not be observed, especially in the aspect of the thermal environment. This aspect could be justified since the occupants (patients) concern is to recover from illness, so the responses were influenced (Liu et al., 2018). One study found that self-perceived health statistically influenced thermal comfort (Hwang et al., 2007). These insignificant values between subjective data and environmental assessment do not mean that this is not important to maintain the physical environment and satisfactory levels of workers and control bacterial and chemical contaminations (Liu et al., 2018). One study based his survey on the post-occupancy evaluation (POE) method to evaluate the satisfaction level of occupants considering the IAQ, thermal environment, lightning and acoustic. This method's application revealed that the survey results corresponded to the physical measurement of noise and IEQ parameters (Tang et al., 2020).

In this research, the authors did not discover a validated Portuguese questionnaire that assessed SBS or BRI in healthcare units.

Relatively to the IAQ parameters assessed by the authors included in this review were relative humidity (HR), carbon monoxide (CO), carbon dioxide (CO<sub>2</sub>),

particle matter (PM), temperature, noise level, illuminance, and other parameters (Table 1). IAQ measured parameters will vary in the selected studies, which are carried out in different countries and healthcare buildings. This can lead to a different prevalence of SBS in various populations.

Relative humidity was assessed in eight studies (Akova et al., 2022; Arikan et al., 2018; Babaoglu et al., 2020a; Hoang Quoc et al., 2020; Jafakesh et al., 2019; Kalender-Smajlović et al., 2022; Sayan & Dülger, 2021; Tang et al., 2020). General SBS symptoms such as asthma or hay fever were related to static electricity and frequently present in hospitals with low relative humidity (Kalender-Smajlović et al., 2022). Low humidity also can cause electrical discharges and variations of the respirable particulate matter in indoor environments (Molina et al., 1989). One study analysed the associations between odours/sensations of air humidity and SBS symptoms and demonstrated that the odds ratio for weekly SBS symptoms was higher than in other categories (Wang et al., 2013).

Carbon monoxide (CO) levels are important indicators of poor IAQ (Babaoglu et al., 2020a). CO was included in three articles (Akova et al., 2022; Babaoglu et al., 2020a; Kalender-Smajlović et al., 2022). The three articles did not find a statistical relation between the risk of SBS and the exposure to the contaminants. One study concluded that relative humidity (RH) and CO were also higher in the experiment building as compared with the control building, and there was a statistically significant association with dry eye symptoms (Idarraga et al., 2020).

The assessment of carbon dioxide (CO<sub>2</sub>) was performed in eight studies included in this review (Akova et al., 2022; Arikan et al., 2018; Babaoglu et al., 2020a; Hoang Quoc et al., 2020; Jafakesh et al., 2019; Kalender-Smajlović et al., 2022; Sayan & Dülger, 2021; Tang et al., 2020). Higher concentrations of this pollutant are associated with older and non-ventilated buildings, provoking SBS symptoms such as fatigue and reducing work productivity. According to one author, the risk of SBS was 2.1 times higher with increased carbon dioxide concentrations (Arikan et al., 2018). The measurement of carbon monoxide and carbon dioxide is important to determine the indicators of poor IAQ (Babaoglu et al., 2020a). High CO<sub>2</sub> levels are related to symptoms like nausea, headaches, nasal irritation, dyspnea, and throat dryness (Kalender-Smajlović et al., 2022). Akova et al., (2022) deviated from the recommended and/or legislated values, and there was not a statistically significant difference between CO<sub>2</sub> concentrations and SBS symptoms.

Particle matter was evaluated in three studies in this review (Babaoglu et al., 2020a; Hoang Quoc et al., 2020; Tang et al., 2020). According to one author, Each unit of PM<sub>1</sub> values increased skin symptoms 1.12 times (Tang et al., 2020). Other authors considered that

the stuffy "bad" air, dust and dirt factors combined with biological and chemical contaminants, may contribute to the increase of SBS symptoms (Hoang Quoc et al., 2020). PM<sub>2.5</sub> values obtained in one study complied with the prescribed standards defined by the authors (Tang et al., 2020). The selected studies only included measurements to quantify the concentration of particles and not their constitution, which is important to analyse skin symptoms (Babaoglu et al., 2020a).

The evaluation of the temperature was considered in eight studies (Akova et al., 2022; Arikan et al., 2018; Babaoglu et al., 2020a; Hoang Quoc et al., 2020; Jafakesh et al., 2019; Kalender-Smajlović et al., 2022; Sayan & Dülger, 2021; Tang et al., 2020). Temperature measurements in one study were in the range of development of bacteria, being necessary to adopt measures to control the growth of bacteria and protect workers and patients (Babaoglu et al., 2020a). According to Arikan et al., (2018), 40.1% of the participants considered the environment had an unsuitable temperature, and it was deemed that temperature affects the emotions and symptoms of employees. In one study conducted by Akova et al., (2022), the risk of SBS was 4.31 times higher for participants who complained about variable room temperature. Although temperature and humidity values in healthcare units are in the normal range, dry eye complaints can be caused by the time spent working with computers (Arikan et al., 2018). High temperatures are also correlated with sneezing, skin redness, and pain in the eyes (Kalender-Smajlović et al., 2022). According to Liu et al., (2018), most of the common complaints were a too high temperature. However, the perception of temperature in the participants is influenced by the seasons (Hwang et al., 2007). Tang et al. conducted a study in a hospital, performed temperature measurements and concluded the rooms were air-conditioned, and the temperature and humidity ratio increased in each subsequent floor level (Tang et al., 2020). A study conducted in 2019 concluded that air temperature was the parameter with the highest deviations from what was legally required, although there was not a statistically significant difference between the number of SBS symptoms and the mean values of air temperature (Sayan & Dülger, 2021).

Noise levels were assessed in six articles included in this review (Akova et al., 2022; Arikan et al., 2018; Hoang Quoc et al., 2020; Kalender-Smajlović et al., 2022; Sayan & Dülger, 2021; Tang et al., 2020). According to one article included in this review, the risk of SBS was 1.2 times higher with the increase in noise levels (Arikan et al., 2018). Arikan et al. considered that the risk of SBS was 3.11 times higher for participants who complained about the noise (Akova et al., 2022). Healthcare units are known for being noisy places. The sources include telephones, alarms, trolleys, ice machines, call systems, nurse shift changes, staff looking at other patients, door closure,

and staff and patients crying or coughing (Ulrich et al., 2003). Also, Kalender-Smajlović et al., (2022) proved that facial skin irritation was found to be more frequent with high noise levels and in this case, the obtained values showed greater deviations from the legally required values for noise level compared to the self-assessment of environmental parameters. According to Akova et al., (2022) the results showed that noise was an important factor influencing the risk of SBS, and Nordström et al., (1995), found that eye irritation was more common in buildings with high ventilation flow and a high noise level from the ventilation system. Low frequency noises were positively correlated with the risk of SBS (Niven et al., 2000). Tang et al., (2020), experienced a higher values of noise and consequently, the dissatisfaction rates was above 60%.

The illuminance values were measured in five studies

**Table 1 - IAQ parameters assessed in each selected article**

	HR	CO	CO <sub>2</sub>	PM	T	Noise	lx
(Kalender-Smajlović et al., 2022)	✓	✓	✓	✗	✓	✓	✓
(Babaoglu et al., 2020b)	✓	✓	✓	✓	✓	✗	✗
(Jafakesh et al., 2019)	✗	✗	✗	✗	✗	✗	✗
(Arikan et al., 2018)	✓	✗	✓	✗	✓	✓	✗
(Akova et al., 2022)	✓	✓	✓	✗	✓	✓	✓
(Hoang Quoc et al., 2020)	✓	✗	✓	✓	✓	✓	✓
(Sayan & Dülger, 2021)	✗	✗	✗	✗	✗	✗	✗
(Vafaeenasab et al., 2014)	✗	✗	✗	✗	✗	✗	✗
(Jafakesh et al., 2019)	✓	✗	✓	✗	✓	✗	✗
(Tang et al., 2020)	✓	✗	✓	✓	✓	✓	✓
(Sayan & Dülger, 2021)	✓	✗	✓	✗	✓	✓	✓
(Kalender-Smajlović et al., 2021)	✗	✗	✗	✗	✗	✗	✗
(Eijkelenboom et al., 2020)	✗	✗	✗	✗	✗	✗	✗

(Akova et al., 2022; Hoang Quoc et al., 2020; Kalender-Smajlović et al., 2022; Sayan & Dülger, 2021; Tang et al., 2020) High light intensity values influence the report of skin dryness, eye pain, and malaise (Kalender-Smajlović et al., 2022). Values for lightning were higher than the recommended defined parameter and were related to the SBS score (Hoang Quoc et al., 2020). Kalender-Smajlović et al., (2022), found a greater deviation between the parameters legally required for the obtained illuminance values, and can cause discomfort and stress in healthcare workers (Morghen et al., 2009). Another study by Kalender Smajlović et al., (2019) found that by comparing different types of exposure with horizontal

illumination values and the degree of stress reported, the percentage of high stress was reduced with an increase in exposure to illumination. According to Tang et al., 2020, it was shown that the average occupant satisfaction level in terms of lightning was "slightly dissatisfied" in the sunny condition and "neutral" in rainy and cloudy conditions, and the satisfaction level for the sunny condition was lower than for the rainy condition.

For the biases, the studies identified the low participation of healthcare professionals (physicians) or only a type of healthcare professionals (Arikan et al., 2018; Kalender-Smajlović et al., 2022), which can influence the results obtained from the questionnaires. Also, stress was often related to the risk of SBS, although multiple factors can lead to the incidence of stress in the workplace. Another identified bias was that in some studies, the questionnaire was applied during the heating season (Kalender-Smajlović et al., 2021), and in other cases applied to a group of patients. This can influence the perceptions and the obtained results. Some studies only used the perception of the questionnaires without performing any measurement; also, some environmental factors are subjective (Babaoglu et al., 2020a).

## CONCLUSION

Only a few studies assessed the IAQ parameters and applied the subjective tools to characterise and analyse the risk of SBS in healthcare workers. Each IAQ parameter influences several categories of SBS symptoms, so when conducting a study in this field, it is important to include a broad range of air quality parameters. In this systematic review, no studies carried out in any Portuguese healthcare units were found, which suggests the need for further research in this area in the Portuguese context.

## ACKNOWLEDGEMENTS

To my family and my friends for all the support to perform this work.

## REFERENCES

- Akova, İ., Kiliç, E., Sümer, H., & Keklikçi, T. (2022). Prevalence of sick building syndrome in hospital staff and its relationship with indoor environmental quality. *International Journal of Environmental Health Research*, 32(6), 1204–1219. <https://doi.org/10.1080/09603123.2020.1862067>
- Andersson, K., Fagerlund, I., Bodin, L., & Ydreborg, B. (1988). Questionnaire as an instrument when evaluating indoor climate. *Healthy Buildings '88 Stockholm*, 1, 139–146.
- Andersson, K., Fagerlund, I., & Larsson, B. (1990). *Reference data for questionnaire MM 040 NA - Indoor Climate (work environment) . Report M5/90* (Issue Department of Occupational and Environmental Medicine).
- Arikan, İ., Tekin, Ö. F., & Erbas, O. (2018). Relationship between sick building syndrome and indoor air quality among hospital staff . *Medicina Del Lavoro*, 109(6), 435–443.

<https://doi.org/10.23749/mdl.v110i6.7628>

Babaoglu, U. T., Milletli Sezgin, F., & Yag, F. (2020a). Sick building symptoms among hospital workers associated with indoor air quality and personal factors. *Indoor and Built Environment*, 29(5), 645–655. <https://doi.org/10.1177/1420326X19855117>

Babaoglu, U. T., Milletli Sezgin, F., & Yag, F. (2020b). Sick building symptoms among hospital workers associated with indoor air quality and personal factors. *Indoor and Built Environment*, 29(5), 645–655. <https://doi.org/10.1177/1420326X19855117>

Baudet, A., Baurès, E., Blanchard, O., Le Cann, P., Gangneux, J.-P., & Florentin, A. (2022). Indoor Carbon Dioxide, Fine Particulate Matter and Total Volatile Organic Compounds in Private Healthcare and Elderly Care Facilities. *Toxics*, 10(3). <https://doi.org/10.3390/toxics10030136>

Blyussen, P. M., Roda, C., Mandin, C., Fossati, S., Carrer, P., de Kluizenaar, Y., Mihucz, V. G., de Oliveira Fernandes, E., & Bartzis, J. (2016). Self-reported health and comfort in “modern” office buildings: first results from the European OFFICAIR study. *Indoor Air*, 26(2), 298–317. <https://doi.org/10.1111/ina.12196>

Dewey, A., & Drahotka, A. (2016). *Introduction to systematic reviews: online learning module Cochrane Training*. <https://training.cochrane.org/interactivelearning/module-1-introduction-conducting-systematic-reviews>

Eijkelenboom, A., Kim, D. H., & Blyussen, P. M. (2020). First results of self-reported health and comfort of staff in outpatient areas of hospitals in the Netherlands. *BUILDING AND ENVIRONMENT*, 177. <https://doi.org/10.1016/j.buildenv.2020.106871>

EPA. (1991). *Indoor Air Facts No. 4 (revised) - Sick Building Syndrome*. [https://www.epa.gov/sites/default/files/2014-08/documents/sick\\_building\\_factsheet.pdf](https://www.epa.gov/sites/default/files/2014-08/documents/sick_building_factsheet.pdf)

Hoang Quoc, C., Vu Huong, G., & Nguyen Duc, H. (2020). Working Conditions and Sick Building Syndrome among Health Care Workers in Vietnam. *International Journal of Environmental Research and Public Health*, 17(10). <https://doi.org/10.3390/ijerph17103635>

Hwang, R.-L., Lin, T.-P., Cheng, M.-J., & Chien, J.-H. (2007). Patient thermal comfort requirement for hospital environments in Taiwan. *Building and Environment*, 42(8), 2980–2987. <https://doi.org/https://doi.org/10.1016/j.buildenv.2006.07.035>

Idarraga, M. A., Guerrero, J. S., Mosle, S. G., Miralles, F., Galor, A., & Kumar, N. (2020). Relationships Between Short-Term Exposure to an Indoor Environment and Dry Eye (DE) Symptoms. In *Journal of Clinical Medicine* (Vol. 9, Issue 5). <https://doi.org/10.3390/jcm9051316>

Jafakesh, S., Mirhadian, L., Pasha, A., Roshan, Z. A., & Hosseini, M. J. G. (2019). Sick Building Syndrome in Nurses of Intensive Care Units and Its Associated Factors. *Journal of Holistic Nursing and Midwifery*, 29(3), 145–152. <https://doi.org/10.32598/JHNM.29.3.145>

Kalender-Smajlović, S., Dovjak, M., & Kuček, A. (2021). SICK BUILDING SYNDROME AMONG HEALTHCARE WORKERS AND HEALTHCARE ASSOCIATES AT OBSERVED GENERAL HOSPITAL IN SLOVENIA. *CENTRAL EUROPEAN JOURNAL OF PUBLIC HEALTH*, 29(1), 28–37. <https://doi.org/10.21101/cejph.a6108>



- Kalender-Smajlović, S., Kuček, A., & Dovjak, M. (2022). The problem of indoor environmental quality at a general Slovenian hospital and its contribution to sick building syndrome. *Building and Environment*, 214. <https://doi.org/10.1016/j.buildenv.2022.108908>
- Kalender Smajlović, S., Kuček, A., & Dovjak, M. (2019). Association between Sick Building Syndrome and Indoor Environmental Quality in Slovenian Hospitals: A Cross-Sectional Study. *International Journal of Environmental Research and Public Health*, 16(17). <https://doi.org/10.3390/ijerph16173224>
- Liu, Y., Wang, Z., Zhang, Z., Hong, J., & Lin, B. (2018). Investigation on the Indoor Environment Quality of health care facilities in China. *Building and Environment*, 141, 273–287. <https://doi.org/https://doi.org/10.1016/j.buildenv.2018.05.054>
- Menzies, D., & Bourbeau, J. (1997). BUILDING-RELATED ILLNESSES. *The New England Journal of Medicine*, 337, 8. <https://cdn1.sph.harvard.edu/wp-content/uploads/sites/2428/2015/06/15.03.16-Building-Related-Illnesses.pdf>
- Molina, C., PICKERING, C. A. C., VALBJORN, O., & BORTOL, M. DE. (1989). *INDOOR AIR QUALITY & ITS IMPACT ON MAN*. [https://www.aivc.org/sites/default/files/members\\_area/medias/pdf/Inive/ECA/ECA\\_Report4.pdf](https://www.aivc.org/sites/default/files/members_area/medias/pdf/Inive/ECA/ECA_Report4.pdf)
- Morghen, I., Turola, M. C., Forini, E., Di Pasquale, P., Zanatta, P., & Matarazzo, T. (2009). Ill-lighting syndrome: prevalence in shift-work personnel in the anaesthesiology and intensive care department of three Italian hospitals. *Journal of Occupational Medicine and Toxicology (London, England)*, 4, 6. <https://doi.org/10.1186/1745-6673-4-6>
- Niven, R. M., Fletcher, A. M., Pickering, C. A., Faragher, E. B., Potter, I. N., Booth, W. B., Jones, T. J., & Potter, P. D. (2000). Building sickness syndrome in healthy and unhealthy buildings: an epidemiological and environmental assessment with cluster analysis. *Occupational and Environmental Medicine*, 57(9), 627–634. <https://doi.org/10.1136/oem.57.9.627>
- Nordström, K., Norbäck, D., & Akselsson, R. (1995). Influence of indoor air quality and personal factors on the sick building syndrome (SBS) in Swedish geriatric hospitals. *Occupational and Environmental Medicine*, 52(3), 170–176. <https://doi.org/10.1136/oem.52.3.170>
- Page, M. J., McKenzie, J. E., Bossuyt, P. M., Boutron, I., Hoffmann, T. C., Mulrow, C. D., Shamseer, L., Tetzlaff, J. M., Akl, E. A., Brennan, S. E., Chou, R., Glanville, J., Grimshaw, J. M., Hróbjartsson, A., Lalu, M. M., Li, T., Loder, E. W., Mayo-Wilson, E., McDonald, S., ... Moher, D. (2021). The PRISMA 2020 statement: an updated guideline for reporting systematic reviews. *BMJ*, 372, n71. <https://doi.org/10.1136/bmj.n71>
- Sadatsafavi, H., Walewski, J., & Shepley, M. M. (2013). Factors influencing evaluation of patient areas, work spaces, and staff areas by healthcare professionals. *Indoor and Built Environment*, 24(4), 439–456. <https://doi.org/10.1177/1420326X13514868>
- Sayan, H. E., & Dülger, S. (2021). Evaluation of the relationship between sick building syndrome complaints among hospital employees and indoor environmental quality. *La Medicina Del Lavoro*, 112(2), 153–161. <https://doi.org/10.23749/mdl.v112i2.11012>
- Smajlović, S. K., Kuček, A., Dovjak, M., Smajlović, S. K., Kuček, A., Dovjak, M., Kalender Smajlović, S., Kuček, A., Dovjak, M., Smajlović, S. K., Kuček, A., & Dovjak, M. (2019). Association between Sick Building Syndrome and Indoor Environmental Quality in Slovenian Hospitals: A Cross-Sectional Study. *INTERNATIONAL JOURNAL OF ENVIRONMENTAL RESEARCH AND PUBLIC HEALTH*, 16(17). <https://doi.org/10.3390/ijerph16173224>
- Tang, H., Ding, J., & Lin, Z. (2020). On-site measurement of indoor environment quality in a Chinese healthcare facility with a semi-closed hospital street. *Building and Environment*, 173, 106637. <https://doi.org/https://doi.org/10.1016/j.buildenv.2019.106637>
- Ulrich, R., Lawson, B., & Martinez, M. (2003). *Exploring the patient environment: an NHS estates workshop*.
- Vafaenasab, M. R., Morowatisharifabad, M. A., Taghi Ghaneian, M., Hajhosseini, M., & Ehrampoush, M. H. (2014). Assessment of sick building syndrome and its associating factors among nurses in the educational hospitals of Shahid Sadoughi University of Medical Sciences, Yazd, Iran. *Global Journal of Health Science*, 7(2), 247–253. <https://doi.org/10.5539/gjhs.v7n2p247>
- Wang, J., Li, B., Yang, Q., Yu, W., Wang, H., Norback, D., & Sundell, J. (2013). Odors and Sensations of Humidity and Dryness in Relation to Sick Building Syndrome and Home Environment in Chongqing, China. *PLOS ONE*, 8(8), e72385. <https://doi.org/10.1371/journal.pone.0072385>
- Zagreus, L., Huizenga, C., Arens, E., & Lehrer, D. (2004). Listening to the occupants: a Web-based indoor environmental quality survey. *Indoor Air*, 14 Suppl 8, 65–74. <https://doi.org/10.1111/j.1600-0668.2004.00301.x>

## BIOGRAPHY of the first author

Ana Silva was born in Gaia, Portugal, in 1995. She has a degree in Environmental Health and a master's degree in Engineering of Safety and Occupational Hygiene. She is currently working as an Environmental Health Technician at the Public Health Department in Famalicão, Portugal.

IVAN MIJAILOVIĆ<sup>1</sup>  
ALEKSANDRA  
ILIĆ-PETKOVIĆ<sup>2</sup>

<sup>1,2</sup> University of Niš,  
Faculty of Occupational Safety

<sup>1</sup>ivan.mijailovic@znrfak.ni.ac.rs  
<sup>2</sup>aleksandra.ilic@znrfak.ni.ac.rs

## PROTECTION OF EMPLOYEES IN CONSTRUCTION INDUSTRY – IN ANTICIPATION OF THE NEW LAW ON OCCUPATIONAL SAFETY AND HEALTH

**Abstract:** *According to the report by the Occupational Safety and Health Administration, there is a large number of workplace injuries among construction workers. Therefore, it is clear that there is a need to take action to reduce this negative trend. Although there is extensive legislation on workplace protection in this area (by-laws and other regulations), the legislator considers that the Law on Occupational Safety and Health itself should regulate some of the issues in this area more precisely. Thus, the draft of the new Law on Occupational Safety and Health contains a far greater number of articles devoted to occupational safety in the construction sector than the current law. This paper analyzes the existing legal solutions in the field of occupational safety in the construction industry (the current Law on Occupational Safety and Health and the applicable bylaws), indicating the problems in their application and making proposals for improvements to be implemented in the new Law on Occupational Safety and Health, which is expected soon.*

**Key words:** construction industry, occupational safety, Law on Occupational Safety and Health.

### INTRODUCTION

Occupational safety and health is one of the oldest labour law issues. The right to safe and healthy working conditions is nowadays treated as an important human, social and economic right. Considering that occupational safety and health is a right guaranteed by the Constitution of the Republic of Serbia (2006), it contributes to increased productivity in the workplace, encourages economic growth and employment and improves the operation of the labour market. The success of the occupational safety and health system is based on effective measures that employers provide to employees with the aim of preventing injuries at work and occupational diseases. Also, employees contribute to their own occupational safety and health with their attitudes and behaviour (Occupational Safety and Health Strategy in the Republic of Serbia for the Period from 2018 to 2022 with the Action Plan for its Implementation, 2018).

In this paper, we explore the characteristics of occupational safety and health in the construction industry, where some of the most serious workplace injuries occur, including those which often result in death. We analyze the positive legal regulations in the field of occupational safety and health in construction, as well as the legal solutions provided in the Draft Law on Occupational Safety and Health. We also make proposals for its improvement with the aim of reducing the number of occupational injuries in construction.

The Law on Occupational Safety and Health is the basic act in the field of OSH (2005). The law prescribes the rights and obligations of employees and employers and provides measures for the prevention of injuries at work and occupational diseases. The law follows the requirements given in existing ILO documents, as well as other international standards in this field. The Labour Law also contains provisions related to OSH.

With regard to the construction sector, the Law on Occupational Safety and Health binds the employer to inform the Labour Inspectorate about the commencement of construction works eight days in advance and submit a report on the construction site layout plan to the Inspectorate. The employer is also obliged to provide, maintain and implement measures for occupational safety and health at the construction site in accordance with the report on the construction site layout plan, and immediately notify the Labour Inspectorate if there are any malfunctions or breakdowns that could endanger the performance of the work (Law on Occupational Safety and Health, 2005). The Law on Planning and Construction regulates the obligations of the responsible contractor and subcontractor. Subcontractors are responsible for providing preventive measures for safe and healthy work of their employees on site (Law on Planning and Construction, 2009). These laws are accompanied by appropriate by-laws.

The procedure of adopting the new Law on Occupational Safety and Health is currently in progress. The reasons for the adoption of the new Law on Occupational Safety and Health can be considered from the perspective of significant economic and social changes that have occurred since November 2005, when the existing law was adopted. Specifically, the law ought to be further aligned with EU standards, special ILO conventions ratified by our country, changes in the legal system of the Republic of Serbia, and changes in policy in the field of occupational safety and health, and adapted to the real needs of people. Also, a more precise or different amendment of certain provisions is required in order to create legal certainty and transparency in its application (Explanation of the Draft Law on Occupational Safety and Health, 2021).

The adoption of the new law is an opportunity to rectify all the shortcomings of the existing law and propose legal solutions that produce better results, i.e. reduction in the number of injuries at work in general, including construction.

## **INSIGHT INTO OCCUPATIONAL SAFETY AND HEALTH IN CONSTRUCTION**

The fundamental legal act in our country, the Constitution of the Republic of Serbia, stipulates that everyone has the right to the necessary protection at work and that no one may renounce these rights (Article 60). These provisions are further elaborated by the Labour Law and the Law on Occupational Safety and Health and accompanying by-laws (several dozens of decrees and regulations). It might be asked what results the existing legal solutions produce in practice. In this paper, we focus on the construction sector.

Based on the Report on the work of the Labour Inspectorate, in 2017 labour inspectors performed 919 inspections relating to fatal, severe, collective and minor injuries at work. Out of 23 inspections regarding fatal injuries at work, as many as 9 (39%) occurred in the construction industry. Concerning injuries with a fatal outcome, out of 16 injuries recorded, 6 (37%) occurred during construction works. Also, 116 out of 870 severe injuries at work occurred on construction sites (Report on work of the Labour Inspectorate for the year 2017, 2017). A similar trend continued in the following years.

According to the data by the Occupational Safety and Health Administration from 2021 (Report of the Occupational Safety and Health Administration for the year 2021, 2022), construction industry records a significant number of injuries at work. For instance, 9 work-related injuries occurred at construction sites, open-pit quarries and open-pit mines. There were 62 work-related injuries on construction sites during the construction of buildings and 20 injuries on construction sites during the demolition, remodelling and maintenance of buildings. There were 3 work-related injuries on underground construction sites and

31 injuries in an open-pit quarry, open-pit mine, excavation and trench.

Taking into consideration the work process, in 2021 there were 8 injuries during excavation, 41 injuries during the construction of new buildings, 15 injuries during the construction of infrastructure, roads, bridges, dams and ports, 12 injuries during remodelling, repair, expansion and maintenance of buildings, and 1 injury during the demolition of buildings (Report of the Occupational Safety and Health Administration for the year 2021, 2022).

In 2021, the distribution of workplace injuries based on the specific physical activity was as follows: 68 injuries during manual holding, grasping, clamping and placing on a horizontal level; 24 during tying, joining, tearing, untying, clamping, unscrewing, screwing and turning; 25 during fixing, hanging, lifting and placing on a vertical level; and 2 during pitching and swinging.

When driving a vehicle or handling mobile and mechanized equipment, 34 injuries at work were recorded; when driving a vehicle or handling mobile and non-mechanized equipment, 13 injuries occurred, as well as 22 injuries to passengers in the vehicles. Many of these activities are common in the construction sector.

According to the source of the injury, in buildings, structures and surfaces at ground level (closed or open, immovable or movable, temporary or permanent) there were 46 injuries; in parts of buildings or structures (doors, walls, barriers, windows, etc.) there were 29 injuries; in buildings, structures and surfaces above ground level (closed or open, immovable or movable, temporary or permanent) there were 14 injuries; in parts of buildings above ground level – immovable (roofs, balconies, doors, windows and stairs) there were 58 injuries; in buildings, constructions and surfaces above ground level – immovable (including passages, fixed ladders and pylons) there were 14 injuries; in buildings, constructions and surfaces above ground level – movable (including mobile ladders and lifting platforms) there were 26 injuries; in structures and surfaces above ground level – temporary (including temporary scaffolding) there were 6 injuries; in structures and surfaces above ground level – floating (including drilling rigs and barge scaffolds) there was 1 injury. Additionally, in buildings, structures and surfaces below ground level (open or closed) there were 4 injuries; in excavations, trenches, wells, openings, landslides and garage pits there were 16 injuries; in subterranean surfaces and tunnels there were 7 injuries; in material supply and distribution systems and piping networks – immovable (for gas, air, liquids, solids, including bunkers) there were 6 injuries (Report of the Occupational Safety and Health Administration for the year 2021, 2022).

The analysis of the data from the Labour Inspectorate on the number of fatal workplace injuries in the construction sector for the period from 2013 to 2016 shows that the greatest number of injuries occurred

during a fall from height (58.7%), earth filling (17.5%) and electric shock (7.9%) (Bulat, Hirose and Protić, 2018).

## POSSIBILITIES FOR IMPROVING THE QUALITY OF LEGAL REGULATIONS

Based on the above, certain trends can be observed in the occurrence of workplace injuries. Given the working environment in which the injury occurred, the source and the cause of the injury and so on, it is clear that construction is the industry with very frequent injuries. For this reason, it is necessary to examine the existing legal solutions and make proposals for their improvement in order to remove the doubts in the application of these regulations and manage the absence of concrete legal formulations and solutions.

The Draft Law on Occupational Safety and Health introduces certain concepts (work site, work at height, underground work, construction, and a collective safety and health facility, etc.), which are not defined in the existing Law of 2005 (Draft Law on Occupational Safety and Health, 2021). This is a novelty relevant to the construction industry.

There is a great number of provisions dedicated to construction, which is a significant positive change. Thus, the Draft Law stipulates that an employer who performs work on the construction of a building in accordance with the regulations on occupational safety and health at temporary or mobile construction sites, as well as an employer who performs work on a work site in accordance with the regulations on occupational safety and health, is obliged to inform the competent labour inspectorate on the commencement of works at least eight days in advance. Employers are obliged to prepare a report on the construction site layout plan in case works last longer than three days in continuity, as well as a report on the work site layout plan, which is submitted to the competent labour inspectorate at least eight days before the commencement of works, together with the notification on the commencement of works. They are also required to provide, maintain and implement on-site safety and health measures at the construction site or work site in accordance with the report on the construction site and work site layout plan and the risk assessment act (Draft Law on Occupational Safety and Health, 2021).

Furthermore, in the event of emergency works conducted on infrastructural facilities for the purpose of eliminating defects or a sudden and uncontrolled event on the facility, the employer is obliged to immediately report the execution of emergency works to the competent labour inspectorate. Such works are to be reported orally and in writing from the time of occurrence. Also, constructors are to comply with the measures in accordance with the act on risk assessment. The Draft Law also determines the obligations of employers when dividing the work space. When two or more employers share a work space while performing work, i.e. when employees of several different

organizations simultaneously perform work in the same work space, employers are obliged to cooperate in the implementation of prescribed measures for the safety and health of employees.

Taking into consideration the nature of the work they perform, employers are obliged to coordinate the activities related to the implementation of measures to eliminate the risk of injury, i.e. damage to the health of employees, as well as to inform each other and their employees or employee representatives about these risks and measures for their removal.

Additionally, the Draft Law stipulates that the employer is obliged to take measures to prevent access to the facility that is a work space, including the facility in the open space, by persons and vehicles that are not authorized to be on site. Employers are also obliged to adapt the tools for work when changing the work process before the commencement of work.

The employer is obliged to provide work permits before starting works at height, underground works, works in a confined space, work in a space with potentially explosive atmospheres, work in an energy facility, work with hazardous chemical substances, and work in zones where there is a serious, unavoidable or immediate danger or harm that may endanger the health of the employee.

All these novelties are a positive change in terms of preventing workplace injuries in the construction industry. What could be improved is the definition of the number of persons responsible for occupational safety and health depending on the number of employees (e.g. one person responsible for occupational safety and health for every 50 employees). This would be especially important for employees on construction sites, since one occupational safety and health professional is not able to visit the construction sites often enough to monitor the implementation of safety measures, which is their legal obligation.

## CONCLUSION

In addition to the fact that construction is in great expansion and represents one of the industries with the highest number of employees, it is also associated with a large number of injuries at work (Mučenski et al., 2018). Today, construction workers are exposed to risks of various types and intensities (Petrović and Anđelić, 2014). Expert analyses have shown that the most common cause of workplace injuries (individual and collective, fatal, serious and minor) in the construction industry is non-compliance with the basic principles of the execution of works, deviation from the prescribed and established work process, work at unsecured height, work along an unsecured perimeter of a building from which it is possible to fall into the surrounding area, work on improperly mounted scaffolding, work in improperly secured excavations, not using prescribed means and equipment for personal protection (primarily working without a protective helmet and protective belt), lack of training for safe and healthy work, carelessness and insufficient focus of

employees, large number of untrained staff, etc. (Ilić Petković and Mijailović, 2022).

The prerequisites for providing safe and healthy work include the regulations that define this issue, measures that the legislator and the employer apply in order to implement the policy of occupational safety and health, awareness of its necessity, and training for safe and healthy work. The legal framework of occupational safety and health and protective measures in construction are different from other industries and they require a special and comprehensive approach. In order to design adequate legal regulations for the protection of employees in the construction industry, it is necessary to identify the shortcomings in the application of existing regulations, amend those regulations and monitor their implementation.

As the new law on occupational safety and health is expected soon, it ought to further regulate some practical issues in construction. The first logical step after the adoption of the new law is to inspect the existing by-laws, which could also be improved (Ilić Petković and Mijailović, 2022). These actions were preceded by the adoption of the Occupational Safety and Health Strategy for the upcoming period (Occupational Safety and Health Strategy in the Republic of Serbia for the Period from 2018 to 2022 with the Action Plan for its Implementation, 2018), whose goal is to reduce the number of workplace injuries, especially fatalities, in various industries, including construction.

Finally, it should be noted that any legal regulation, no matter how high-quality and comprehensive it is, requires effective application in practice. Therefore, it is highly desirable to intensify the inspection supervision at construction sites. It should be emphasized that the goal of the inspection is not only to punish violators of specific regulations, but also to achieve closer cooperation with employers and employees so as to establish better understanding of the regulations on occupational safety and health in construction. This implies the preventive role of the inspection, which would contribute to the reduction of unfavourable statistics regarding the number of occupational injuries in the construction industry.

## REFERENCES

- Bulat, P., Hirose, K., Protić, J. (2018). *Occupational Safety and Health in Construction Industry in Serbia*, Geneva: ILO.
- Constitution of the Republic of Serbia (2006). Official Gazette of the Republic of Serbia, No. 98/2006.
- Draft Law on Occupational Safety and Health (2021).
- Explanation of the Draft Law on Occupational Safety and Health, 2021  
[https://www.minrzs.gov.rs/sr/dokumenti/predlozi-i-](https://www.minrzs.gov.rs/sr/dokumenti/predlozi-i-nacrti/uprava-za-bezbednost-i-zdravlje-na-radu-0)

[nacrti/uprava-za-bezbednost-i-zdravlje-na-radu-0](https://www.minrzs.gov.rs/sr/dokumenti/predlozi-i-nacrti/uprava-za-bezbednost-i-zdravlje-na-radu-0) [Accessed 25 August 2022].

Ilić Petković, A., Mijailović, I. (2022). Practical Challenges in The Application of Occupational Safety Regulations in Civil Engineering, 8th International Professional and Scientific Conference Occupational Safety and Health, Zadar, Croatia.

Law on Occupational Safety and Health, Official Gazette of the Republic of Serbia, No. 101/2005, 91/2015, 113/2017.

Law on Planning and Construction, Official Gazette of the Republic of Serbia, No. 72/2009, 81/2009, 64/2010, 24/2011, 121/2012, 42/2013, 50/2013, 98/2013, 132/2014, 145/2014, 83/2018, 31/2019, 37/2019, 9/2020, 52/2021).

Mučenski, V. et al. (2018). Analysis of Falls to the Level Below in Construction Industry of Serbia, Proceedings from the Conference 50 Years of Higher Education, Science and Research in Occupational Safety Engineering, Niš, Serbia.

Occupational Safety and Health Strategy in the Republic of Serbia for the Period from 2018 to 2022 with the Action Plan for its Implementation (2018). Official Gazette of the Republic of Serbia, No. 96/2018.

Petrović, M., Andjelić, K. & Prvulović Petrović, M. (2014). Safety of Workers carrying out construction works and use of machinery, *Military Technical Courier*, 62(2), pp. 151-165.

Report of the Occupational Safety and Health Administration for the year 2021 (2022).

<https://www.minrzs.gov.rs/sr/dokumenti/izvestaji/uprava-za-bezbednost-i-zdravlje-na-radu-0> [Accessed 25 August 2022].

Report on work of the Labour Inspectorate for the year 2017 (2018). Ministry of Labour, Employment, Veteran and Social Affairs' Competitiveness and Jobs Project, Belgrade.

## ACKNOWLEDGEMENTS

This research was funded by the Ministry of Education, Science and Technological Development of the Republic of Serbia, pursuant to the Contract on the realization and financing of scientific research work of scientific research organizations in 2022, number 451-03-68/2022-14/ 200148.

## BIOGRAPHY of the first author

**Ivan Mijailović** is an associate professor at the Faculty of Occupational Safety, University of Niš, Serbia. He graduated from the Faculty of Mechanical Engineering in Niš and obtained his Ph.D. degree at the Faculty of Occupational Safety in Niš. He has published numerous scientific papers in the field of occupational safety, environmental protection, energy efficiency and alternative energy sources.





NIKOLA ŠUKALO<sup>1</sup>  
NEBOJŠA ČURČIĆ<sup>2</sup>

<sup>1</sup>Tehpro d.o.o., Belgrade

<sup>2</sup>Academy of Applied Technical  
Studies Belgrade

<sup>1</sup>nikola.sukalo@tehpro.rs

<sup>2</sup>ncurcic@atssb.edu.rs

## FINANCIAL PLANNING FOR ENFORCEMENT AND CONTROL OF OHS PREVENTIVE MEASURES

**Abstract:** *The Law on Occupational Health and Safety, enacted in 2005, has introduced some principal changes to the field. This Law defined the rights, obligations, and responsibilities of employers and employees, as well as penalty provisions for non-implementation of the defined obligations. Minimum requirements as well as advanced activities can be managed if finances are planned properly. The budgeting process has an impact on the performance of an organization. Additionally, it eliminates penalty provisions, which can affect the overall business. Health and safety professionals need to have certain knowledge about business, economics, and related fields in order to plan resources for the implementation, maintenance, and improvement of the occupational health and safety system in a given organization.*

**Key words:** financial planning, budgeting, occupational safety and health

## INTRODUCTION

The connection between the performance of the occupational health and safety system and the company's financial indicators is strong and direct and it has been repeatedly proven. In addition, the effects of economic crises, whether at the company, national, regional, or global level, affect occupational safety and health. According to Boustras and Guldenmund (2018), the financial crisis has had a serious impact (apart from the obvious economic impact) at both the social and the political level occupational health and safety (OHS) being one of the most affected areas. This is just one of the indicators of the complexity of the interaction between economic parameters and safety and health in workplaces.

In addition to the direct impact of continuous and consistent application of optimal preventive measures to reduce the frequency and severity of injuries and illnesses at work, the economic effects also play a significant role for the company's overall operations. According to Paez and Genaidy (2017), Economic Assessment of the Work Environment (EAWE) is a financial framework that helps the management forecast the financial benefits of health and safety implementations. The five-step process comprises (1) a health assessment to identify critical elements in the work environment, (2) an action plan to address gaps, (3) performance targets based on internal goals and external benchmarks, (4) transformation of the expected improvements in health and safety into the expected performance outcomes, and (5) implementation in stages, from individual jobs to the entire organization.

However, in order for occupational safety and health programs to be uninterrupted and thereby achieve their goals, adequate planning of the necessary resources is the basic prerequisite. In this context, planning the necessary finances for clearly defined activities in the coming period is one of the elementary tasks of occupational health and safety experts, who must provide the necessary and realistic inputs for budgeting at the company level. As stated in the standard for occupational health and safety management (ISO, 2018), the actions planned should primarily be managed through the OHS management system and should involve integration with other business processes, such as those established for the management of the environment, quality, business continuity, risk, and financial or human resources. The implementation of the actions taken is expected to achieve the intended outcomes of the OHS management system.

## LEGAL FRAMEWORK

According to the Law on Occupational Health and Safety of the Republic of Serbia, all safety measures have to be organized and implemented by the employer, i.e. the person responsible for their implementation is the CEO. In most cases, whether the OHS experts are selected from the permanent staff or from a contracted licensed company for services in the field of OHS, it is considered by the CEO that they are the ones responsible for and in charge of all the work in the field of OHS. The starting point should be to prepare the overarching "zero state" report on the overall state of the company (organization,

technological process, existing documentation etc.) and present it to the responsible person.

In all business entities (companies, entrepreneurial stores, public entities, education institutions, healthcare institutions, etc.) there is a direct link between preventive OHS measures and economic parameters of business.

Legal regulation states that business entities have an obligation to implement OHS measures, and if they are not implemented, a business entity may be subject to punitive measures enforced by the labour inspection. Business entities as well as the responsible persons employed at those business entities may be punished financially. These economic measures increase the awareness of the responsible person – the CEO. Periodic control is not defined, and possible penalties are unpredictable and are related to other factors.

Insurance policies for all employees of the company and for employees who perform high-risk activities, as well as expenses related to implementing all preventive measures, are the costs of doing business, and as such must be expressed in the price of the services that the company provides. These are the permanent economic parameters that the company is burdened with, but in the case of an accident, the policy covers the cost.

In the case of serious injuries at work, the labour inspectorate initiates an investigation. Representatives of the Ministry of Interior and an investigative judge, as well as an expert witness, are also involved. Before starting the procedure, the work process must be halted at the site of the accident. Statements about the event are then taken from the witnesses, manager(s), the COO, the CEO, and the OHS Expert. The complete OHS documentation required by the law is given for inspection. All those activities incur expenses to the company, bearing in mind that the employees are engaged in different tasks and no longer involved in their daily work. The cost of employee sick leave and the cost of hiring a replacement are also covered by the employer. Moreover, the company has to cover court (office) fees and fines for the company and fines for the responsible person. Productivity of employees in the facility where a serious or fatal injury occurred falls significantly and it needs time to return to its previous level.

It can be concluded from the aforementioned examples that in every company there is a link between setting up the OHS system and budgeting funds for the implementation of preventive OHS measures and that if companies do not invest in prevention at some point, it will cost them more when accident do happen, which will force them to invest additional funds later.

The period in which the budget is planned should be observed through other factors, such as activities of the company and the locations of company's buildings, and, based on that data, the deadlines for realization of

activities should be determined, internally and externally.

For the completion of external activities, there needs to be a procedure for procurement of the service and a timely agreement on the deadlines for the completion that will not exceed the existing deadlines. For example, no one should issue a work order for an employee to perform a job that involves operating a forklift knowing that the document on vehicle safety has expired. Also, the examination of multiple forklifts should not be performed at the same time, so that one vehicle is always ready to be used.

## **PLANNING**

To plan well, it is necessary for management to know the theory of planning and modern methods and techniques, to be fully familiar with the work that is to be planned and its subsystems and their processes. The management must have a highly developed awareness of the importance of planning and how it affects their business. Bad planning can affect business in the long term.

Ideally, planning should involve the whole system, from the management to the individual, and in every segment of the business, employees should work toward the same goal, according to the defined plan.

To plan well, it is necessary to possess sufficient data. Thorough preparation is an important prerequisite for successful implementation of the plan.

The benefits of successful planning include the following:

- To be able to perform additional tasks;
- To ensure an integral (overall) view of the development of the company and all its segments;
- To ensure continuous planning flow and continuous development of plans for a certain period;
- To enable all activities to be organized in such a way as to achieve the maximum effect with minimal investments;
- To provide feedback on the success of the plan;
- To establish clearly defined obligations and responsibilities for plan fulfilment;
- To have a written plan defined by the management, mainly by relying on knowledge and experience. Plans must be defined so that they can be easily and quickly changed during the planning period in accordance with the changes made in the company.

Plans can be classified based on different criteria. Some of the criteria for partition include the following:

- Time period: long-, medium-, and short-term;
- Organizational level: strategic, operational, and tactical;
- System type: technical and organizational;

- Phase of the life cycle of the system: peacetime plans, crisis plans, plans for dealing with imminent war danger, war plans;
- System objectives: usage plans, development plans, work plans;
- The scope and level of the system: plan for the entire organization, plans of organizational units, individual-personal plans;
- Elements planned: material assets, workforce, funding, information needs, energy needs, space, time, products, works and services, measures, and procedures;
- Scope of activities regulated by the plan: basic and supplementary;
- Characteristics of the plan: qualitative, quantitative, etc.

Depending on the specific organizational system, the procedure for implementing the plan contains the following phases:

- Collection, selection, classification, and analysis of information on the conditions, behaviours, or necessary conditions for the realization of the planned conditions and behaviour of the system in the past planning periods, of interest to the branch and the higher-level system to which the observed organizational system belongs;
- Analysis of the current state of the company;
- Acquisition, selection, classification, and analysis of information on objective assumptions, subjective factors, and elements of the situation that will operate in the planning period for which the planning activity is performed;
- Checking of the real-life conditions for achieving the goals defined and set by the Planning Act as a task;
- Design of the plan project – development of plans;
- Linking of the plan to other organizational plans;
- Launch of plans – distribution of plans;
- Making of final adjustments to the plans and finally formulation of plans and drafting of planning instruments;
- Control of the adoption of plans;
- Monitoring and control of the implementation of plans.

By adopting the plan, the top management decides on the goals that are to be achieved, establishes policies for achieving the desired goals, selects a strategy for achieving the goals, and explores the plan, as a governing instrument, for the realization of the goals.

There are many methods, techniques, and software applications that can be used for planning in organizational systems. All planning information will rarely be available, which makes planning limited and requires a flexible and thorough approach when gathering information. First of all, it is necessary for the person who collects the information to know

exactly what kind of information is required and who to ask for it.

## ANNUAL PLANNING OF OHS ACTIVITIES

Planning is an obligation assumed by the responsible OHS person and it includes general and special activities.

General activities include periods of visiting work areas and ancillary spaces to obtain insight into the state of facilities, work equipment, behaviour of employees, terms for presenting the report on the results achieved in the previous year, terms for drafting the activity plan for the next year, and so on.

Special activities are all activities related to the zero-sum report by priority. The scheduling for the realization of activities depends on the legal requirements, both for the previous periodic activities and for the current state according to the zero-state report.

Being priorities during the planning process, activities that could potentially lead to injuries or result in fines from the authorities must be taken into consideration.

Additional activities that can improve the OHS system but that do not significantly affect the reduction of professional risks and that require significant financial investments should be planned for a longer period of time. These plans are drafted by the responsible OHS person with the support of investment and maintenance services.

### What data is necessary for developing an OHS activity plan?

The field of occupational health and safety is very extensive and requires insight into numerous documents and tours of facilities and work environments. It is sometimes difficult for the responsible OHS person to complete the legally required activities in practice.

The responsible OHS person is obligated to request the following information from the top management:

- Planned Investments;
- Maintenance and overhaul plan.

### When are activities specified and how to define priorities and schedules of activities?

The annual plan of activities and resources is defined by the OHS expert in accordance with the finance plans of the company. Usually this covers the period from August to December of the current year for the following year. The purpose of the activity plan is to define the timeline for the completion of certain activities defined by the law or according to other criteria. Also, the activity plan and the budget function in the field of occupational health and safety, which means that the financial assets that the CEO should

allocate/plan for each activity for the specified period are shown.

### **How to evaluate the necessary funds for the implementation of the plan?**

The amount of funding is variable and depends not only on the activities of the company, but also on the existing state of OHS in the company. This means that a plan for all OHS activities should be devised first to determine the necessary funds. Allocation of funds for OHS is often significant, but the basic economic principle is for management to ensure that this investment will reduce potential costs in case of work accidents in the future.

Experience has shown that it is much cheaper to invest preventively than to pay for treatment, sick leave, rehabilitation, misdemeanour penalties, damages claims from employees or their family members, or to be damaged by fire. Unsafe work causes a decline in productivity, job loss, poor market image, and other negative effects.

Costs due to injuries, professional illnesses, and work-related illnesses are high, as 11% of these are borne by the employer and about 13% by employees. At the same time, this piece of data also reveals the link between profit and occupational safety and between employers and employees. Thus, both the employer and the employee benefit from observing OHS requirements.

### **To whom is the plan submitted and who can verify it?**

The plan of activities in the field of OHS is submitted for the following calendar year in September of the current year to the responsible person – the CEO – for their perusal.

The plan is delivered before the drafting of the business plan of the company and is used for quality planning of the necessary funds to ensure compliance with legal obligations.

Upon perusal of the plan, the CEO may request additional information about the obligations and estimated funding for the plan execution.

### **How to justify activities and necessary funds of the proposed plan?**

When drafting the plan defining activities and assessing funds, the responsible OHS person/persons must be prepared to explain how they collected the data that determined the prices for the services and the quantities they displayed in the plan.

### **Percentage of planned funds for OHS in the planned gross income of the company**

The previous practice of working with foreign companies shows that OHS budgets are acceptable for the company if they amount to no more than 2-5% of the entire budget of a project.

## **CONCLUSION**

For the implementation and improvement of the OHS system in an organization, quality planning is a basic prerequisite. In this context, OHS experts in organizations must actively participate in the development of OHS financial plans in direct cooperation with senior management and all other services. Knowledge in the field of financial planning of operational activities is therefore a necessary competence that must be developed both through formal education of experts and through informal education such as seminars and training. Both OHS experts and employers, who have the overall responsibility for all processes in the field of occupational safety and health in their organizations, should be aware of the necessity of such an approach.

## **REFERENCES**

- Boustras, G. & Guldenmund, F.W. (2018) *The effects of the global financial crisis on Occupational Safety and Health (OSH): Effects on the workforce and organizational safety systems*, Safety Science, Volume 106, pp. 244-245
- International Organization for Standardization [ISO] (2018) *ISO 45001 Occupational health and safety management systems – Requirements with guidance for use*
- Law on Occupational Safety and Health*, Official Gazette of The Republic of Serbia, No. 101/2005, 91/2015, 113/2017
- Paez, O.R. & Genaidy, A.M. (2017) *Financial assessment of health and safety programmes in the workplace*, Theoretical Issues in Ergonomics Science, 18(3), pp. 241-265

## **BIOGRAPHY of the first author**

**Nikola Šukalo**, M.Sc. in Applied Studies in Safety Engineering, B.Sc. in Economics, was born in Belgrade in 1986. He is employed at Tehpro, a company providing services in the field of safety in the implementation of projects with foreign and regional partners.



# OESEM

19<sup>th</sup> INTERNATIONAL CONFERENCE  
"MAN AND WORKING ENVIRONMENT"

OCCUPATIONAL AND ENVIRONMENTAL SAFETY  
ENGINEERING & MANAGEMENT

## *Environmental Safety Engineering and Management*







MIRJANA GALJAK<sup>1</sup>

<sup>1</sup>Academy of Applied Sciences  
Kosovo and Metohija, Leposavić,  
Serbia

<sup>1</sup>mirjana.galjak@akademijakm.edu.rs

## ENVIRONMENTAL MANAGEMENT IN A MODERN ORGANIZATION

**Abstract:** *Environmental management is an effort to eliminate negative tendencies and impacts in relation to the environment and human health. Given that the concept of organizations has changed over time and that they represent open stochastic systems and should be viewed as subsystems of the wider environment (internal and external environment), this paper, in addition to operationalizing basic research concepts, considers the impact of modern organizations and organizational culture on the creation and development of environmental management.*

**Key words:** environmental management, modern organization, organizational culture

### INTRODUCTION

To adequately manage the environment, it is necessary to have relevant information about the state, processes, structure, organization, and problems that occur in it, as well as to apply appropriate legal instruments. Environmental management at the level of modern organizations, which, depending on the activity they are engaged in, can be major or minor polluters, is an integral part of the environmental management system. The best-known instruments of environmental management applied in modern organizations are: environmental management systems (EMS); environmental performance indicators (EPI); environmental audit (EA), and environmental management (EMA). ISO 14000 standards indicate what environmental management should look like.

Organizations were created for people to achieve certain goals and meet their needs. In the process of satisfying one's needs through work, one initiates negative changes and processes in the environment. Considering the seriousness and dramatic changes that humans cause in the ecosystems of nature through their work, there is an indisputable need to harmonize technical-technological and economic development with the ecological order in nature. Organizations should mobilize all employees and align their systems, strategies, resources, and structure with all requirements related to the environmental management system.

### CONCEPTUAL AND THEORETICAL APPROACH

#### Environmental management

Regarding the conceptual definition of environmental management, the terms "ecological management" or "eco-management" are also used today, although the

term "environmental management" is used more frequently in foreign literature.

In our country, both terms have a similar meaning and refer to several management activities related to ecology, and therefore to the environment. If we look at the differences between these two concepts, we can see that the term "environmental management" is related to management when solving problems that are directly related to the environment, specifically to water, air, waste, etc. (waste management, water resources management, etc.). On the other hand, the term "ecological management" is used in the management of individual economic entities to achieve compliance with all requirements related to the state and conditions of the environment through economic activities (Đorđević, 2005).

There is no generally accepted and universal definition of environmental management due to the breadth and variety of topics. However, ecological management is determined by characteristic goals, so it could be said that it represents an environmental protection management system, which aims to establish a systematized and unified approach in industry and other branches and which ensures that environmental reasons become an integral part of business strategy and practice. If management is taken to refer to the process by which economic or other activity is planned, organized, coordinated, and controlled, then ecological management refers to the process by which economic or other activity in the field of ecology is planned, organized, coordinated, and controlled in an ecological way, or by which goals in the domain of ecology are achieved (Kolomejceva-Jovanović, 2010).

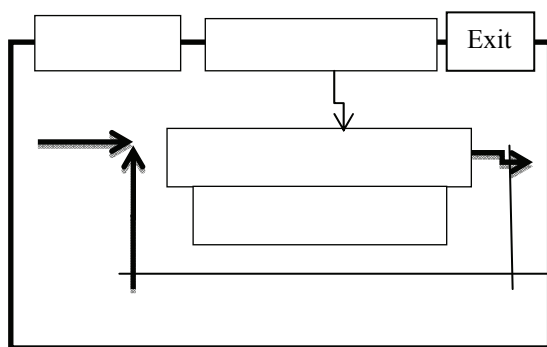
Environmental management in the broadest sense can be defined as a discipline focusing on the relationship between humans and the environment (Bartula, 2016). Management represents the aspiration to eliminate negative tendencies and influences in relation to the

environment and human health. Managing the environment means carrying out basic strategic activities that determine the means and define the protection criteria as well as the directions of environmental development (Jovanović and Božilović, 2018). Environmental management is a technique used to manage environmental processes. It defines what is environmentally friendly as well as what is an environmental, economic, social, and technological barrier to improving the protection process (Barrow, 2006).

### **Modern organization**

The very notion of an organization is derived from the Greek word *organon*, which literally means a tool, a device. An organization is a group of two or more people working in a structured way to achieve one or more goals. The following elements that characterize each organization are listed in the literature: organizations are social entities (consisting of two or more persons); they are carefully structured to get the job done efficiently; they are goal-oriented and have the resources that members of the organization will use; organizations have management that directs all other elements (people, resources) towards achieving goals. The concept of organization is not static but changes over time in each environment (Mašić, 2010)

The growing complexity of business, the emphasized interdependence of phenomena, and the exponential growth of knowledge create the conditions for the development of the modern theory of organization. With the development of computer systems and quantitative methods, as well as system theory, there is a modern theory of organization, where the organization and its parts are observed according to the principles of the systems approach, as shown in Figure 1. The systemic approach views the organization as an open system, made up of subsystems, parts, and processes that achieve balance through regulation. Modern organizations, whether economic or non-economic, require constant management actions to operate and develop in a complex and dynamic environment (Ibid.). Larger organizations are complex to manage, as they need to invest more energy to coordinate their departments, require enormous resources, and are slow to respond to changes in the environment.



**Figure 1.** *Systems approach to the organization (Ibid.)*

All successful economies today generally have large private sectors that adapt to changes in the environment. Internal coordination in companies is more efficient and that is why they are growing, unlike small interdependent companies. An efficient bureaucracy with the superior skills of its employees is a new intellectual tool. The emergence of information technologies was necessary for the development of modern organizational schemes. The pattern of creating modern organizations is based on an explicit analysis of the problem. Raising "the model from the level of the subconscious, they made it available for verification and improvement" (Milanović, 2012). This is the very foundation of modern organizations.

Every modern organization is affected by the environment in which it operates. One of the definitions of the environment is "the system of forces that surround the organization and affect the way it functions as well as the access to its resources" (Petković, 2009). The organizational environment is usually divided into internal (the totality of connections and relations between and within the company's resources) and external (individuals or groups of organizations that are outside the organization but are also in direct interaction with it) (Todorović, 1998).

Organization as a structure is a feature of all social systems that differ from natural systems in their characteristics. Natural and social systems represent a dynamic system whose parts are in a variable relationship based on the principle of feedback (Crnogorac, 2009). Whether they are small organizations or companies with their autonomous units (departments), all activities and processes that take place within them, as well as products, have a certain impact on the environment in one of the phases of the life cycle.

### **MODERN ORGANIZATION AND THE ENVIRONMENT**

When introducing the ISO 14000 standard, it is important to consider the relationship between environmental aspects, environmental impact, and its control systems. Elements of activities, products, and services of a modern organization that interact with the environment are called environmental aspects (Heleta, 2010). The term "environmental aspect" itself should be understood as an aspect through which an organization affects or may affect the environment (for example, the environmental aspect "wastewater discharge" implies that an organization may have an impact on the environment, i.e. pollute watercourses, land, etc.). Environmental impact is defined as any environmental change, improvement, or deterioration, which is entirely or partially a consequence of the activities of the organization, its products, or its services (Aćamović, 2001).

A modern organization needs to identify the environmental aspects that it can manage and those that

it impacts. Aspects of the environment that are harmonized with national normative acts in the field of environmental protection and that are included in the management procedure in environmental protection are the following (Heleta, 2010): waste generation; wastewater discharge; rainwater discharge; air emission sources; exhaust emissions from cars; chemical operations; water use operations; energy operations; use of natural resources; cessation of product production; and waste disposal.

**Table 1.** *Examples of connections between activities, aspects, and environmental impact* (Bartula, 2016; Aćamović, 2001)

Activity, product, or service	Aspect	Consequences of environmental impact
Product: Paper printing	Emission of organic solvents into the atmosphere	Air pollution by organic solvents
Activity: Transport of dangerous substances	Potential spill of dangerous substances in case of an accident	Pollution of land/water, endangered biodiversity
Service: Supply of settlements with hot water (district heating)	Combustion of fossil fuels	Emission of harmful gases

Activities related to the products and services of an organization produce environmental impacts (positive or negative). All these environmental impacts, as well as any changes in them, are defined by the standard. The elements of the control system are designed and applied according to the aspects of the organization's environment and environmental impact (Milanović, 2012).

At some stage in their life cycle, almost all products, services, and activities have a certain impact on the environment (local, regional, or global). To determine the interaction of products and processes of the organization with the environment, it is necessary to (Heleta, 2010):

- select the categories of products and services of the organization;
- identify environmental aspects for each product category;
- assess the significance of the environmental impact for each identified aspect;
- define measures to eliminate, reduce, and/or manage risks.

## ENVIRONMENTAL MANAGEMENT AND ORGANIZATIONAL CULTURE AS THE BASIS FOR DEVELOPMENT PLANNING

Nowadays, environmental management, as well as organizational culture, should be the basis for development planning. Environmental management should be a part of the business practices within all organizations, which clearly define their strategy based on continuous improvement of their performance. This is especially challenging for organizations that deal with sustainable development planning in terms of the way they opt for new ways of thinking and behaviours that are based on a critical and scientific approach (Nikčević, 2017).

Organizational culture cannot be precisely defined because it is something that is perceived, felt, and sensed (Obradović, 2003). It is a powerful tool for shaping the behaviour of all members of the organization and it represents a system of assumptions, beliefs, values, and norms, which members of an organization have developed and adopted through shared experience and problem-solving and which significantly influence their thinking and behaviour (Janićijević, 2011). Organizational culture is a context within which individuals and teams work (Mumford et al., 2002.) and it is created by the joint experience of members of the organization, which they gain by solving everyday problems (Lojić, 2010).

Organizational culture has a strong influence on the thinking and behaviour of employees and its influence is felt in all aspects of a business. Therefore, for the successful operation of the organization, it is important that there be harmony between the principles of management of the organization and its organizational culture (Obradović, 2003).

In addition to business goals, one of the strategic goals of every successful company is the protection of the environment. To achieve this goal, it is necessary to create an organizational culture that will guide the behaviour and activities of employees to use resources in a sustainable manner. In fact, proper strategic planning tools, as well as constant improvement of their processes and selection of appropriate leaders, help organizations achieve their goals. Only a strong organizational culture that keeps its employees together can have good and efficient environmental management, which consists of the company's desire to eliminate or minimize negative tendencies and impacts on the environment and human health (Nikčević, 2017).

Environmental management and environmental safety are integral parts at all organizational levels, and they should be coordinated with occupational safety. There

are four basic phases in each environmental management strategy (environmental policy, planning, introduction and implementation, measurement, and evaluation, etc.):

- identification phase (identification and inventory of all sources of pollution and obtaining of information on potential effects of pollution);
- monitoring phase (monitoring and measuring pollutants in order to learn what air quality is like in a particular area, the extent of its pollution, and how to respond appropriately);
- assessment phase (sum of all environmental information obtained in previous phases); and
- regulation phase (application of adequate measures and activities to manage the environment more efficiently).

Therefore, the effect that organizational structure will have on environmental management depends on the company culture. Culture, on the one hand, can positively influence the motivation and commitment of employees, reduce conflicts, and facilitate control over the functioning of the organization. On the other hand, a strong organizational culture with wrong assumptions, values, and beliefs that are not harmonized with the environment can have a negative impact on the business success of the organization (Janićijević, 2011). Proper environmental management means that basic strategic activities are carried out through an appropriate organizational culture, which will define the directions of development and determine the means for environmental protection (Nikčević, 2017).

## CONCLUSION

Nowadays, services, products, and activities in an organization can have both positive and negative impacts on the environment. A modern organization needs to identify the environmental aspects that can be managed or controlled, as well as those over which it can have an influence.

For proper environmental management, there must exist a certain type of organizational culture, as well as an appropriate environmental policy that is in line with the quality policy, occupational health and safety policy, and other policies. The analysis of different types of organizational culture points to the conclusion that not every type of organizational culture is suitable for the creation and development of environmental management.

Thus, only the organizational culture that adapts to changes in the environment and is open to change and innovation, that is creative, stable, flexible, and able to generate knowledge, talent, and ability, that is prone to accept risk, and that favours teamwork, follows the democratic principles of management, and focuses on results forms a good basis for the development and

implementation of environmental management principles. This type of organizational culture, which includes ecological ethics, ecological consciousness, and ecological culture, is founded on economic logic (Nikčević, 2017, p.85).

## REFERENCES

- Dorđević, B. (2005). *Ekološki menadžment*, ICIM plus, 2005, Kruševac.
- Mašić, B., Babić, L., Dorđević-Boljanović, J., Dobrijević, G., Veselinović, S. (2010) *Menadžment, principi, koncepti i procesi*, Univerzitet Singidunum, Beograd.
- Barrow, C. (2006). *Environmental Management for Sustainable Development*, Routledge, London and New York.
- Crnogorac, Č., Rajčević, V. (2009). 'Neki oblici zagađivanja radne sredine', *1st International Conference Ecological Safety in Post-modern Invironment, Banja Luka, RS, BiH, 2009*
- Jovanović, D.G., Božilović, S. (2018). 'Ekološki menadžment u funkciji održivog razvoja', *Second International Scientific Conference on Economics and Management-EMAN*, 2018.
- Mumford, D.M., Scott, M.G., Gaddis, B., Strange, M.J. (2002). 'Leading creative people: orchestrating expertise and relationships', *The Leadership Quarterly*, 13(6), pp. 705-750.
- Nikčević, G. (2017). 'Organizaciona kultura u kontekstu projektovanja menadžment sistema životne sredine', *Ekonomija, teorija i praksa*, 10(3), pp. 79-87.
- Todorović, J., Đuričin, D., Janošević, S. (1998)/. *Strategijski menadžment*, IZIT, Beograd.
- Obradović, K.R., Cvijanović, J.M., Lazić, J.M.: 'Organizaciona kultura kao ključni faktor internog okruženja preduzeća', *Industrija*, vol. 31, br. 3-4, pp. 51-68.
- Kolomejceva-Jovanović, L. (2010). *Hemija i zaštita životne sredine: ekološka hemija*, Monografija nacionalnog značaja, Beograd, Savez inženjera i tehničara Srbije.
- Bartula, M. (2016). *Menadžment životne sredine*, Fakultet za primenjenu ekologiju Futura, Beograd, Univerzitet Singidunum.
- Heleta, M. (2010). *Projektovanje menadžment sistema životne i radne sredine*, Beograd, Univerzitet Singidunum.
- Milanović, M.M., Lješević, M.A., Milinčić, M.A. (2012). *Ekomenadžment*, Beograd, Geografski fakultet, Univerzitet u Beogradu.
- Mihajlović, M., Aleksić, J., Jovičić, J. (2009). 'ISO standardi u zaštiti životne sredine', *1st International Conference Ecological Safety in Post/Modern Environment, Banja Luka, RS, BiH, 2009.*
- Petković, M., Janićijević, N., Bogičević-Milikić, B. (2009). *Organizacija - dizajn, ponašanje, ljudski resursi, promene*, Beograd, Ekonomski fakultet - Centar za izdavačku delatnost.



Aćamović, N.M. (2001). *Razvoj sistema upravljanja zaštitom životne sredine*, Novi Sad, Naučni institut za veterinarstvo.

Janićijević, N. (2011). *Uticaj liderstva na organizacionu kulturu*, *Ekonomika preduzeća* 59, (5-6), pp. 215-226.

Lojić, R. (2010). 'Organizaciona kultura', *Vojno delo*, br.3, pp. 258–277.

## **BIOGRAPHY**

**Mirjana Galjak** was born in 1971 in Kosovska Mitrovica. She graduated and obtained her master's degree and doctorate at the Faculty of Occupational Safety in Niš. Her main areas of research include occupational safety, occupational and environmental management, natural disasters, emergency management, etc. She works as a professor of vocational studies at the Academy of Applied Sciences, Kosovo and Metohija.





NIKOLA IGIĆ<sup>1</sup>  
ANA STOJKOVIĆ<sup>2</sup>  
NENAD KRSTIĆ<sup>3</sup>  
DRAGAN ĐORĐEVIĆ<sup>4</sup>  
GORAN JANAČKOVIĆ<sup>5</sup>  
IVAN KRSTIĆ<sup>6</sup>

<sup>1</sup> Kvalitet a.d.  
Joint-stock company for  
quality testing  
<sup>2,5,6</sup> University of Niš,  
Faculty of Occupational Safety  
<sup>3,4</sup> University of Niš, Faculty of  
Sciences and Mathematics,  
Department of Chemistry

<sup>1</sup>nikola.igic@kvalitet.co.rs  
<sup>2</sup>ana.stojkovic@znrfak.ni.ac.rs  
<sup>3</sup>nenad.krstic84@yahoo.com  
<sup>4</sup>dragance73@yahoo.com  
<sup>5</sup>goran.janackovic@znrfak.ni.ac.rs  
<sup>6</sup>ivan.krstic @znrfak.ni.ac.rs

## TREND ANALYSIS OF ISO 14001 STANDARD CERTIFICATION AT THE NATIONAL AND INTERNATIONAL LEVEL

**Abstract:** *ISO 14001, an internationally accepted standard that sets requirements for an environmental management system, assists organizations in improving their environmental performance in order to gain a competitive advantage and stakeholder's trust. Improvement of environmental performance in certified organizations implies regulatory compliance, employee leadership and involvement, improved reputation and fulfillment of stakeholder requirements, communication, objectives achievement, providing competitive and financial advantages, evaluating the performance of suppliers, etc. Accordingly, many organizations have chosen environmental management system certification, either as part of an integrated management system or as an individual certification, in order to demonstrate their commitment to environmental protection. When drafting strategic documents and action plans, the number of certified organizations is commonly used to assess eco-performance. The trend of ISO 14001 standards certification at the national and international levels is examined in the paper, along with a comparison to other fundamental standards of the integrated management system.*

**Key words:** ISO 14001, environmental protection, certification.

## INTRODUCTION

Technical standardization at the global level was established by the International Organization for Standardization (ISO). Nowadays, the ISO portfolio includes 167 members of national certification bodies and about 20 000 developed standards, which are practical tools to support businesses around the world (ISO, 2022). On the other hand, the ISO 9001 and ISO 14001 standards are the most well-known and widely used for management systems, and they now serve as the foundation for business standardization. Also, ISO 45001, which refers to the management system for safety and health at work, tends to become one of the three basic standards, although it was officially published as recently as 2018.

The standard that currently has global significance refers to the environmental management system. This International Standard defines requirements for the effective and efficient management of significant environmental risks. Also, This standard is a generic standard for management systems, which means that it can be applied to any organization regardless of their size, activity and industry sector (Song et al., 2017). The implementation of the ISO 14001 standard reduces the risks of possible penalties for violating laws and other regulations, improves organizational efficiency, which reduces its negative impact on the environment and mitigates any potential negative effects on the organization. By harmonizing operations with the

requirements of this standard, the environmental impact of business activities, products and services is constantly improving. In addition, appropriate programmes are implemented in order to achieve general and specific objectives. Therefore, the organization is expected to:

- establish an appropriate environmental policy,
- identify environmental aspects, arising from products and services, in order to assess the impact of these aspects on the environment,
- identify legal and other stakeholder requirements to which the organization is committed,
- set priorities and set appropriate main and individual objectives,
- establish a strategy and programmes for the implementation of environmental policy through the implementation of main and individual objectives,
- ensure compliance of the implemented environmental management system with the established environmental policy,
- continuously improve its environmental management system through the processes of planning, management, control, defining corrective measures and conducting internal and external audits,

- be able to adapt to changes in the environment, incidents and accident situations (Johnstone, 2020; Johnstone & Hallberg, 2020; Mosgaard et al., 2022).

Certification of environmental management according to the ISO 14001 standard increases the trust of stakeholders in the organization's business and its attitude towards the environment and opens up new opportunities in markets where ecological production is important. In accordance with that, an analysis of ISO 14001 certification at the national and international levels was conducted from 2018 to 2020, followed by a comparative analysis in relation to the basic standards of the integrated management system (ISO 9001 and ISO 45001).

## MATERIALS AND METHODS

The data analyzed in this research were obtained by a credible national certification body for certified companies in the Republic of Serbia, while the data on international certification were taken from the ISO organization (ISO, 2022).

The paper will not mention the names of certified organizations, as well as certification bodies due to the information security policy. The basic scientific methods used for the purpose of the research will be induction and deduction, analysis and synthesis. In addition to the mentioned methods, a descriptive method will be used to describe standards, analyse the content of relevant literature and documents, analyze research results using a comparative method, as well as statistical methods in the data processing.

## RESULTS AND DISCUSSION

The implementation and certification of the ISO 14001 standard are most often done due to facilitated tender operations and international trade, as well as other social, political, economic and environmental benefits (Prajogo et al., 2012). Organizations have the option to take a more structured approach to their internal environmental management processes thanks to ISO 14001 (ISO 14001, 2015). In this sense, the standard is more process-oriented than product or service performance (Boiral & Henri, 2012). However, through a cycle of continuous improvement, better environmental performance is often presented as an indirect result of the EMS implementation process (Zorpas, 2010). According to the literature, there is an expectation that companies with certified EMS have the optimal level of environmental performance (Albelda, 2011). This can be considered a motivation for some organizations to implement EMS, although specific levels of environmental performance are not prescribed by the ISO 14001 standard itself. Instead, ISO 14001 provides companies with guidelines and requirements for implementing, maintaining, and improving internal environmental management processes. Consequently, improved environmental performance is an indirect effect of efficient EMS,

which is one of the reasons for following the ISO 14001 certification trends.

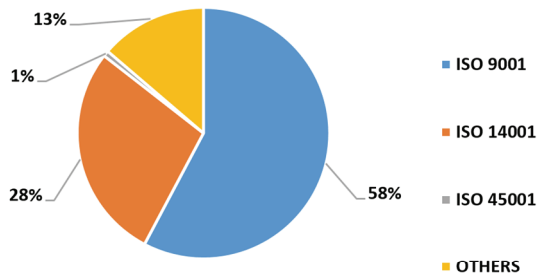
## Analysis of certified organizations at the national level

The goal of sustainable development is to reach a higher and better level of development in terms of economic, environmental and social requirements. Traditional environmental policies have relied primarily on the mandatory implementation of legislation to reduce pollution and reduce the environmental impact caused by industry and other sources of pollution. However, regulatory issues are the external context of the organization, while the ultimate goal is to achieve constraints that would avoid financial penalties and other intangible losses such as a bad reputation or damaged relationships with the local community.

According to statistical data in the Republic of Serbia for the period from 2018 to 2020, there is a growing trend of certificates issued for ISO 14001: 2015. In the first year of the analyzed period, 1169 certificates were issued, then 1275 and 1629 respectively. The only standard that has a better implementation trend is ISO 9001. ISO 9001 defines the quality management system in the company. It more precisely defines the requirements that the company must follow, and implement in practice, in its daily work in order to align its operations with these widely accepted norms. On top of everything is the mission and vision of the company and of course, the strategic objectives whose monitoring and implementation are achieved by introducing this quality standard. This standard is applicable in all companies regardless of their size, so it can be used equally successfully in large organizations, as well as in the SMEs (small and medium-sized enterprises).

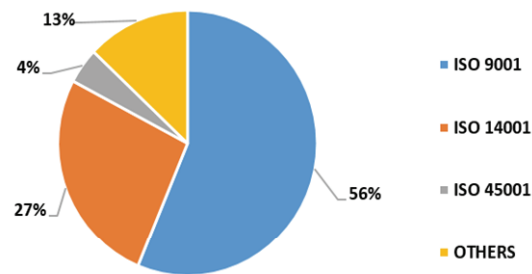
As for ISO 9001 in Serbia and the region, it is fully implemented in the segment of large companies, partly in medium-sized companies, and more recently it is becoming increasingly popular in small-sized companies. In order to comply with these global business standards, small businesses are expanding, preparing for the introduction of this standard, control audits and finally ISO 9001 certification. Another important reason that initiates great interest in the introduction of standards is competitiveness and the possibility of participating in tenders of public companies.

Figure 1 shows that more than half of the certified organizations in the total share of 58% are committed to ISO 9001, followed by ISO 14001 with 28%, which is twice as many certified organizations compared to all other standards considered (ISO 45001:2018, ISO 22000:2005&2018, ISO IEC 27001:2013, ISO 13485:2003&2016, ISO 50001:2011, ISO 20000-1:2011, ISO 22301:2012, ISO 28000:2007, ISO 39001:2012, ISO 37001:2016).



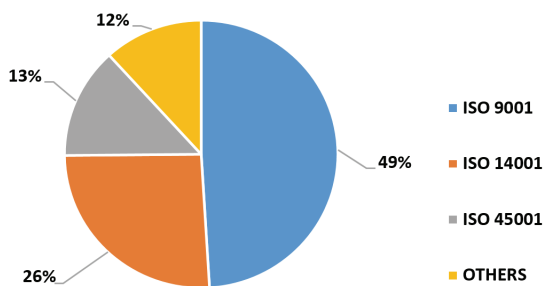
**Figure 1.** Certified organizations in the Republic of Serbia according to reference standards for 2018

Figure 2 shows the trend of certification in 2019, which is similar to that of the year that was previously analyzed. With a slight increase in certified companies according to the ISO 45001 standard which defines the requirements for safety and health at work.



**Figure 2.** Certified organizations in the Republic of Serbia according to reference standards for 2019

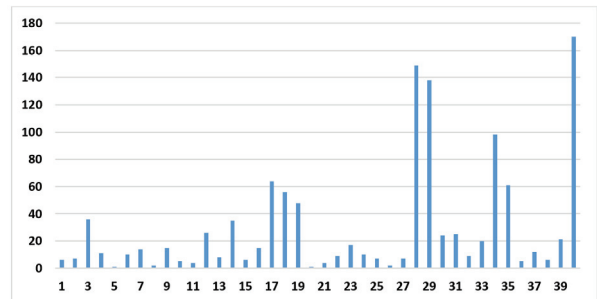
The trend of certification in 2020 is shown in Figure 3. It is indicative that the number of companies certified according to ISO 45001 has drastically increased as a result of the transition period in which all organizations were obliged to adapt their operations to comply with this version of the standard by 2021. Also, it can be noticed that the pandemic had no negative impact on the number of certified companies, and there was even an increase compared to the previous two years.



**Figure 3.** Certified organizations in the Republic of Serbia according to reference standards for 2020

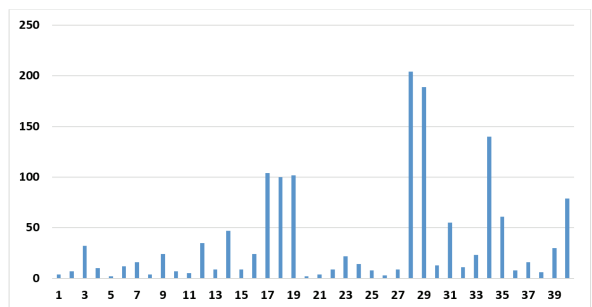
Based on the research conducted by Majstorović et al. (2015), the number of issued certificates in the Republic of Serbia doubled between 2012 and 2013, with 831 issued certificates in 2012 and 762 issued certificates in 2013.

Figure 4 shows the number of certified organizations by activities, ie NACE codes. The leather and shipbuilding industries have the fewest issued certificates, each with one. On the other hand, the greatest number of certified organizations is in construction (149), trade (138) and other industries (170).



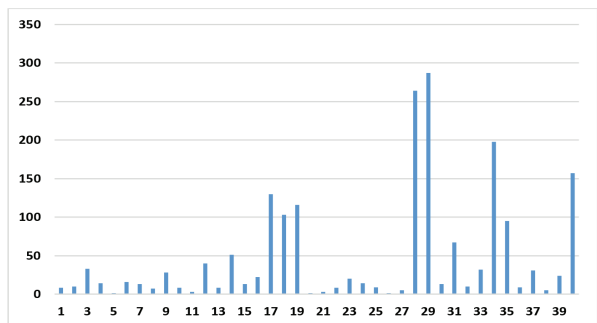
**Figure 4.** Certified organizations in the Republic of Serbia according to activities for 2018

Compared to 2018, in 2019 there was a growth in the metallurgy and metal processing industry, production of machinery and equipment for work, as well as electrical and optical equipment (Figure 5). In line with that, the growth of certified companies that provide engineering services is logical.



**Figure 5.** Certified organizations in the Republic of Serbia according to activities for 2019

Figure 6 shows a similar growth trend of certified organizations as in 2019 with dominant peaks in the field of construction, trade, and engineering services.



**Figure 6.** Certified organizations in the Republic of Serbia according to activities for 2020



It can be concluded, based on the analysis that there is a positive trend of certification of companies in the Republic of Serbia according to the ISO 14001 standard. Also, in accordance with economic circumstances, the dominant certification sectors are in the field of construction and design, and engineering services. The reason for this is the growing number of foreign funds that place a high value on the verification of eco-performance of contractors and subcontractors and socially responsible businesses (EBRD, 2008).

### Analysis of certified organizations at the international level

Since the release of the ISO 14001 standard in 1996, EMS certification has undergone intense growth on the international stage. By the end of 2011, there were 267,457 certificates issued in 158 countries (ISO, 2012). In the period from 2000 to 2010, the number of certificates issued worldwide increased almost 11 times (Marimon et al., 2011). During the analyzed period from 2018 to 2020, the number of certified organizations in the world is over 300,000 per year. The country that leads in the number of issued certificates is China with 136,715 certificates in 2018, 134,926 in 2019, and 168,129 issued in 2020. Numerous researches have been done to confirm the justification of a large number of certified companies according to the ISO 14001 standard. According to the research of Wenlong et al. (2015) there is a simultaneous increase in sales and costs after the implementation of ISO 14001. Adoption of the ISO 14001 standard increases the value of the company, but also requires significant costs, such as the cost of equipment to reduce pollution, pollution control and prevention costs, fees for the implementation and maintenance of standards, staff training costs, etc.

Many Chinese companies do not have the practice of investing in environmental management and for this reason, the costs of adopting ISO 14001 may be higher for Chinese companies than for companies in developed countries. This may be the reason why the conventional cost-saving benefits provided by ISO 14001 have not been observed among Chinese companies (Christmann, 2000; Hart & Ahuja, 1996; Klassen & McLaughlin, 1996). Nevertheless, many Chinese companies adopt ISO 14001 for easier export because it helps to overcome the “green” barrier to entry set by developed countries. In addition, ISO 14001 certification can act as a positive tool for regulatory compliance, and reducing compulsory environmental inspections. These non-financial benefits greatly facilitate business and are therefore crucial when deciding to invest in EMS.

Based on the diagrams from Figures 7, 8 and 9, it can be concluded that there is a similar trend of certification at the global and national levels. Also, there is a noticeable increase in organizations certified according to the ISO 45001 standard. The dominant standard here is ISO 9001, which has a tradition of 35

years. However, ISO 14001 tends to take precedence given the growth trend each year.

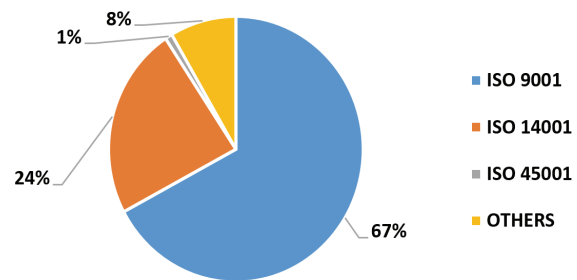


Figure 7. Certified organizations in the world according to reference standards for 2018

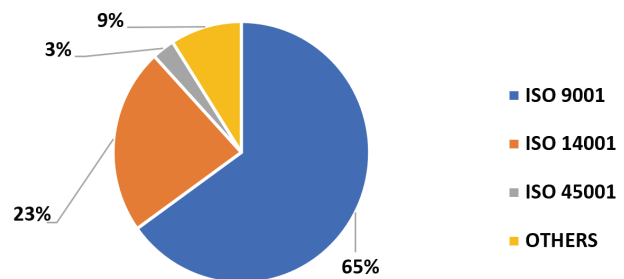


Figure 8. Certified organizations in the world according to reference standards for 2019

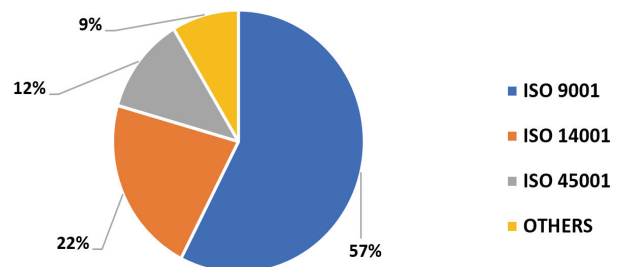


Figure 9. Certified organizations in the world according to reference standards for 2020

Figure 10 shows the number of certified organizations by activities, ie NACE codes.

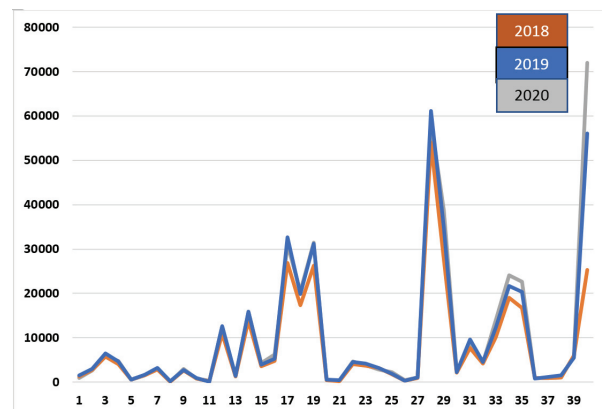


Figure 10. Certified organizations in the world by activity

It can be noticed that the growth trend is similar for all three analyzed years. The dominant peaks are in the field of construction, trade, metallurgy, and metal processing industry and the production of electrical equipment. It is characteristic that in 2020, the number of certified companies in the field of IT and other service activities increased. The number of certified organizations in other industries has also doubled for the period from 2018 to 2020. Consequently, it can be concluded that the certification of ISO 14001 standards in the future will have a growth trend that will extend to other activities in line with economic development and economic opportunities in the world.

## CONCLUSION

Management system certification is imperative for modern business. Organizations mostly choose an integrated management system to optimize documented information and reduce costs. The ISO 14001 standard, which is the second most popular in the business world, helps employers overcome the “green” trade barrier set by developed countries. Furthermore, the adoption of ISO 14001 may qualify firms to establish a cooperative relationship with multinational companies, which often have requirements for a green supply chain. Additionally, ISO 14001 is relevant for every organization. The implementation of ISO 14001 requirements and guidelines help the company in environmental risk management, and automatically reduces the exposure of the company, its business, assets and persons to environmental disasters that can pose a high risk to the entire corporate structure (persons, capital, and business). The trend of ISO 14001 certification is increasing both nationally and internationally, which confirms the interest of the business world to invest in eco-business in all relevant activities.

## REFERENCES

Albelda, E. (2011). “The role of management accounting practices as facilitators of the environmental management: evidence from EMAS organisations”, *Sustainability Accounting, Management and Policy Journal*, 2 (1), pp. 76-100.

Boiral, O, Henri, J.F. (2012). “Modelling the impact of ISO 14001 on environmental performance: a comparative approach”, *Journal of Environmental Management*, 99, pp. 84-97.

Christmann, P. (2000). “Effects of “best practices” of environmental management on cost advantage: The role of complementary assets”, *Academy of Management Journal*, 43(4), pp. 663-680.

European Bank for Reconstruction and Development (EBRD), Environmental protection policy and social policy, May 2008

Hart, S.L, Ahuja, G. (1996). “Does it pay to be green? An empirical examination of the relationship between emission reduction and firm performance”, *Business Strategy and the Environment*, 5(1), pp. 30-37.

ISO 14001:2015 Environmental management systems - Requirements with guidance for use

Johnstone, L. (2020). “The construction of environmental performance in ISO 14001-certified SMEs”, *Journal of Cleaner Production*, 263.

Johnstone, L, Hallberg, P. (2020). “ISO 14001 adoption and environmental performance in small to medium-sized enterprises”, *Journal of Environmental Management*, 266.

Klassen, R, McLaughlin, C. (1996). “The impact of environmental management on firm performance”, *Management Science*, 42(8), pp. 1199-1214.

Mosgaard, M, Bundgaard, A, Kristensen, H. (2022). “ISO 14001 practices - A study of environmental objectives in Danish organizations”, *Journal of Cleaner Production*, 331, 2022.

Majstorović, V, Marković, M, Kuzmanović, D, Mačuzić, J, Marinković, V, Šibalića, T, Bekčić, S, Pejović, G. (2015). “Business standardization in Serbia and world - comparative study”, *Tehnika - kvaliteta i metrologija*, 24, pp. 884-892.

Marimon, F, Llach J, Bernardo M. (2011). “Comparative analysis of diffusion of the ISO 14001 standard by sector of activity”, *Journal of Cleaner Production*, 19, pp. 1734-1744.

Prajogo, D, Tang, A.K, Lai, K.H. (2012). “Do firms get what they want from ISO 14001 adoption? An Australian perspective”, *Journal of Cleaner Production*, 33, pp. 117-126.

Song, H, Zhao, C, Zeng, J. (2017). “Can environmental management improve financial performance: an empirical study of A-shares listed companies in China”, *Journal of Cleaner Production*, 141, pp. 1051-1056.

Wenlong, H, Chong, L, Jianguo, L. (2015). “Jing, Impacts of ISO 14001 adoption on firm performance: Evidence from China”, *China Economic Review*, 32, pp. 43-56.

Zorpas, A. (2010). “Environmental management systems as sustainable tools in the way of life for the SMEs and VSMEs”, *Bioresource Technology*, 101 (6), pp. 1544-1557.

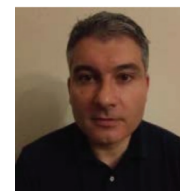
<https://www.iso.org/home.html> (accessed 19.05.2022)

<https://www.iso.org/the-iso-survey.html> (accessed 19.05.2022)

[http://www.iso.org/iso/iso\\_survey2011\\_executive-summary.pdf](http://www.iso.org/iso/iso_survey2011_executive-summary.pdf), (accessed 19.05.2022)

## BIOGRAPHY of the first author

**Nikola Igić** was born in Niš in 1970. He graduated from the Faculty of Mechanical Engineering in Nis and acquired the title of a graduate mechanical engineer. He was a Lead Engineer in the Laboratory for Gas Appliances Joint Stock Company for Quality Testing "QUALITY" Nis. He is currently the Head of the Sector for Assessment of Quality Management Systems.





JOVANA TOPALIĆ  
MARKOVIĆ<sup>1</sup>  
VLADIMIR MUČENSKI<sup>2</sup>

<sup>1,2</sup> University of Novi Sad,  
Faculty of Technical Sciences

<sup>1</sup>jovanatopalic90@uns.ac.rs  
<sup>2</sup>mucenskiv@gmail.com

## LEGAL ASPECTS OF THE RISK ASSESSMENT MODEL CREATED FOR WASTEWATER TREATMENT PLANTS

**Abstract:** *This paper analyses the legal aspects of the preliminary risk assessment model for the construction process of wastewater treatment plants. The legal aspects are defined as a risk group for creating the model. The Legal Risk Group has been identified as a separate risk group with thirteen specified risks. The defined risks are specified after the literature review and the previous project experiences. From project management in construction, these risks can be further upgraded with tools such as PESTEL and SWOT methods.*

**Key words:** risk, legal, preliminary risk assessment model, wastewater treatment plant

### INTRODUCTION

The preliminary risk assessment model for the construction process of wastewater treatment plants was developed as a part of a doctoral thesis. It is a unique model made after detailed literature research, which included a review of journals, legal acts, and books, and collection of information about operational plants (Topalić Marković et al., 2020). The model was developed because there is no unified methodology for identifying and quantifying risks connected to the civil engineering processes for wastewater treatment facilities. This model was created after detailed research using the Delphi method, with six groups of identified risks. One of the risk groups, which is important for the planning and design phase of construction, is the legal group of risks. The other groups include financial and economic risks, logistics risks, ecological risks, management risks, and design risks.

Every country has a law regulating specific issues such as wastewater treatment and reuse. The European Union established many procedures and directives regarding wastewater treatment (European Union, 2000). According to Riffat, 2013, legal regulation plays a significant role in developing and applying wastewater treatment processes. The Republic of Serbia adopted all the necessary regulations on wastewater treatment, but the main problem is the adherence to the laws and bylaws in practice.

In Serbia, all legal regulations for pollutants are defined in the Law on Water (Official Gazette, 2016). The spatial plan of a municipality determines the location of the wastewater treatment plant, and the Law on Planning and Construction defines it. Location requirements are the basic point for defining potential risks for the construction process of wastewater treatment plants (Topalić Marković, 2022). When defining the location requirements, the requirements for

design and connection are also defined. One of the risks is inadequate connection of the plant. Uncertainties and risks in the field of wastewater treatment are considered according to the design guidelines. Historically, the design itself is based on the requirements of the institutions, design standards accepted by the industry, or legal regulations (industry standards tailored to specific requirements with individual amendments) (Jaroslav Černi, 2015).

The German ATV standard (ATV, 1995) and the instructions from the book *Wastewater Treatment Disposal and Reuse* (Tchobanoglous, et al., 2003) are most frequently used in Europe. In practice, risk factors in the design instructions (Tchobanoglous et al., 2003; Grady et al., 2011; ATV, 1995) are based on the improvement of the design that meets the requirements of the effluent (such as ammonia content or total nitrogen content) but not the construction elements and processes of the project.

The risk model, which was developed as a part of the doctoral thesis is different from the standard guidelines because it includes 37 risks strictly connected to the civil engineering aspects of projects. This model is essential in the initial phases and design phases, when poor decisions can subsequently lead to poor efficiency and financial losses. For Serbia, it is crucial to know how to manage the risks, because there will be many future projects for wastewater treatment plants required for Serbia's EU accession.

### LEGAL RISKS

The greatest responsibility for identifying risks, analyzing them, and responding to them lies with the investor and their management team. Risk analysis provides the best results when performed at the very beginning of the project, although it is also important in other phases due to the disturbances that may occur (Boznak, 1991). It is important to emphasize risk



identification in the first phase of the project (investor selection, financial issues, location requirements, contracts with public utility companies, environmental organisations, etc.) as well as in the design phase (Topalić Marković et al., 2020).

Civil engineering risks can be analysed in different ways based on their consequences, probability, types, and origin. According to Kishan et al., 2014, civil engineering risks relate to design, logistics, legal acts, management, environmental protection, finances, and politics.

After a detailed analysis of the literature, laws and bylaws, and projects, the legal risks will be defined. This group of risks comprises thirteen risks. Evidence for every risk can be found in the literature. These risks are the following:

1. Frequent changes and modifications of laws and by-laws
2. Incompatibility between regulations of the foreign investor and regulations of the country where the work is to be done
3. Unfamiliarity with the existing laws and by-laws
4. Delay in resolving a contractual dispute between the investor and the designers in the design phase
5. Untimely issued design terms and licences by the public company
6. Inadequate requirements for connecting the wastewater treatment plant to the infrastructure
7. Inadequate estimation of public procurement impact on the project lifecycle and deadline
8. Inadequate criteria for selection of the project dealer
9. Inadequate criteria for selection of the project designer
10. Inadequate criteria for selection of the contractor
11. Inadequate view of the optimal way of project realization contracting
12. Inadequate spatial plan of the municipality (location, dimension, and size) (based on interviews with experts and personal experience of the authors)
13. Issues with obtaining the building permit.

Each of these risks is explained and defined for the preliminary risk assessment model.

1. Frequent changes and modifications of laws and by-laws

This risk is identified in Wideman, 1992 and Kishan et al., 2014.

Risk explanation: According to frequent changes in laws and bylaws, there can be a change of rules, which are not up-to-date, and design time or norms may become stricter. In that case, there is a need to make changes to the project, which requires additional time for designers and resources.

2. Incompatibility between regulations of the foreign investor and regulations of the country where the work is to be done

This risk is identified through experience in practice.

Risk explanation: Any differences in legal regulations of foreign investors and investment countries can pose a problem. For example, parameters of water quality may be approved by the investor, but they are not applicable to investment countries. The investors can set requirements for lower quality of water in the country of investment.

3. Unfamiliarity with the existing laws and by-laws  
This risk is identified in Wideman, 1992.

Risk explanation: During the design process there can be frequent changes in laws and bylaws, which can lead to mistakes in the design process.

4. Delay in resolving a contractual dispute between the investor and the designers in the design phase

This risk is identified in Wideman, 1992.

Risk explanation: This risk is associated with the problems of an investor approving one solution but also asking for changes, while the designer is not prepared to make the changes. Also, the investor may not be satisfied with the new changes. Processes such as these slow down the project design and cause delays to the project.

5. Untimely issued design terms and licences by the public company

This risk is identified in Aziz, 2013.

Risk explanation: Due to delays in issuing the terms and licences, there can be delays in the project. This can also result in financial and economic losses. Even though there are legal regulations in Serbia for this field, there are still problems for the designer and the investor because of the delays.

6. Inadequate requirements for connecting the wastewater treatment plant to the infrastructure

This risk is identified in CEDEF, 2015.

Risk explanation: During the setting of the location requirements, there can be problems with the connection of plants to the infrastructure because of the distance or the price of connection. Such a situation can interfere with the designer's solution and cause delays to the project and problems with the installation.

7. Inadequate estimation of public procurement impact on the project lifecycle and deadline

This risk is identified in Ogunsanmi, 2011.

Risk explanation: There can be a problem while choosing the contractor for specific phases of the project. Complaints regarding the choice of investor are fairly common, which causes delays. The procurement procedure and the tender procedure are also important.

8. Inadequate criteria for selection of the project dealer

This risk is identified in Aziz, 2013.

Risk explanation: Inviting a tender is very important for every project. Contractors with the lowest bidding price are often the ones ultimately chosen. This can impact the quality of the project documentation as well as the quality of the project and the finishing tasks. Likewise, the lowest-bid contractors will usually provide low-



quality equipment, which can create problems for the very plant operation.

9. Inadequate criteria for selection of the project designer

This risk is identified in Aziz, 2013.

Risk explanation: Same issues as the eighth risk.

10. Inadequate criteria for selection of the contractor

This risk is identified in Aziz, 2013.

Risk explanation: Tender's organization is very important for every project. There can be the situation with the cheapest contractor and choosing of them. This can impact the quality of the project documentation and also a quality of the project and finishing tasks. Same issues as the eighth risk.

11. Inadequate view of the optimal way of project realization contracting

This risk is identified in Wideman, 1992.

Risk explanation: The choice of inadequate contract can impact work from different aspects: costs, quality, delay, and impacts on the environment and health and safety.

12. Inadequate spatial plan of the municipality (location, dimension, and size) (based on interviews with experts and personal experience of the authors)

Risk explanation: The problems pertaining to wastewater treatment, which can be observed while creating the Municipal Spatial Plan, include inadequate dimensions of the facility, the capacity of the location, and to the unfeasibility of expanding to other locations.

13. Issues with obtaining the building permit.

This risk is identified in Wideman, 1992 and Aziz, 2013.

Risk explanation: If there are any problems with obtaining the building permit, the delays are bound to happen, especially in the contracting phase. This relates to the late building permit.

The described risks are identified in this way for the first time and it is important to note that they are used for the Delphi method. Experts in this method had a right to give mark to every risk. For the method is used the Licert scale, where marks are from one to five. After the Delphi method was applied, the scores for each risk were calculated. These scores are implemented further in the preliminary risk assessment model.

The discussed preliminary risk assessment model can be implemented as a part of future research and can then be used in the PESTEL or the SWOT method. These methods are qualitative, but also essential for the beginning of project implementation.

## CONCLUSION

This paper analysed the legal aspects of the preliminary risk assessment model for the construction process of wastewater treatment plants. The legal aspects were defined as a special risk group for creating the model.

The Legal Risk Group was identified as a separate risk group with thirteen specified risks. The defined risks were specified after a literature review and the previous project experiences. From project management in construction, these risks can be further upgraded with tools such as PESTEL and SWOT methods.

The paper presented a part of the research within the project "Multidisciplinary theoretical and experimental research in education and science in the fields of civil engineering, risk management and fire safety and geodesy", conducted by the Department of Civil Engineering and Geodesy, Faculty of Technical Sciences, University of Novi Sad.

## REFERENCES

- ATV (1995). *German ATV Rules and Standards "ATV – A 106E Design and Construction Planning of Wastewater Treatment Facilities"*, GFA, Hennef, Germany, 1995 [online] Available at: [http://dl.mozh.org/up/ATV-A\\_106E.pdf](http://dl.mozh.org/up/ATV-A_106E.pdf)
- Aziz R.F. (2013). *Ranking of delay factors in construction projects after Egyptian revolution*, Alexandria Engineering Journal 52(3), pp. 387–406, Available at: <https://doi.org/10.1016/j.aej.2013.03.002>
- Boznak R.G. (1991). *On the horizon – a 24-month car, the question is, who will achieve it?*, Project Management Journal, 22(3), pp. 11–16, 1991 [online] Available at: <https://www.pmi.org/learning/library/24-month-car-development-competition-success-2086>
- CEDEF (2015): *Use and treatment of municipal and industrial wastewater in the Republic of Serbia*, CEDEF and the Provincial Secretariat for Urbanism, Construction and Environmental Protection, Novi Sad, Serbia, 2015. Available at: <https://drive.google.com/file/d/0B5otVVM41sb5S2tSVERFOERON3c/view> (in Serbian)
- European Union (2000). The Directive 2000/60/EC for uniformed framework in the water policies, European Parliament
- Grady, Jr., C. P. L., Daigger, G. T., Love, N. G., Filipe (2011). *C. D. M. "Biological Wastewater Treatment"*, 3<sup>rd</sup> ed., IWA Publishing, London, UK
- Jaroslav Černi Institute for the Development of Water Resources (2015). *Strategy of Water Management in the Republic of Serbia*, Jaroslav Černi Institute for the Development of Water Resources, Belgrade, Serbia Available at: <http://www.rdvode.gov.rs/doc/Strategija%20upravljanja%20vodama.pdf> (in Serbian)
- Kishan, P., Bhatt, R., Bhavsar, J. J. (2014). *A Study of Risk Factors Affecting Building Construction Projects*, International Journal of Engineering, Research & Technology, 3(12), pp. 831–835, [online] Available at: <https://www.ijert.org/a-study-of-risk-factorsaffecting-building-construction-projects>
- Official Gazette (2016) Law on Water, The Republic of Serbia
- Ogunsanmi, O. E., Salako, O. A., Ajai, O. M. (2011). *Risk Classification Model for Design and Build Projects*, Journal of Engineering, Project, and Production Management, 1(1), pp. 46–60,

<http://doi.org/10.32738/JEPPM.201107.0006>

Riffat, R. (2013). *Fundamentals of Wastewater Treatment and Engineering*, CRC Press, Boca Raton, FL, USA

Tchobanoglous, G., Burton, F. L., Stensel, H. D. (2003). *Wastewater Engineering, Treatment and Reuse*, 4th ed., McGraw-Hill Education, New York, NY, USA

Topalić Marković J., Mučenski V., Savić D., Velkovski T., Peško I., Tomaš L. (2020). Risk Assessment Model for Planning and Design Processes of Wastewater treatment plants, *Periodica Polytechnica Civil Engineering*

<https://doi.org/10.3311/PPci.16740>

Topalić Marković J. (2022). *Preliminary risk assessment model of wastewater treatment plant construction*, PhD thesis, Faculty of Technical Sciences, University of Novi Sad

Wideman, R. M. (1992). *Project and Program Risk Management: A guide to managing project risks and opportunities*, Project Management Institute, Newtown Square, PA, USA

## ACKNOWLEDGEMENTS

The paper presents a part of the research conducted within the project “Multidisciplinary theoretical and experimental research in education and science in the fields of civil engineering, risk management and fire safety and geodesy” by the Department of Civil Engineering and Geodesy, Faculty of Technical Sciences, University of Novi Sad.

## BIOGRAPHY of the first author

**Jovana Topalić Marković** was born in Sarajevo, Bosnia and Herzegovina, in 1990.

She received a diploma in civil engineering and a Ph.D. degree in civil engineering from the University of Novi Sad, Faculty of Technical Sciences. Her main areas of research include civil engineering, project management, the Delphi method, etc.

She is currently working as a Research Trainee at the Faculty of Technical Sciences, University of Novi Sad.



MILICA STOJANOVIĆ<sup>1</sup>  
ROBERT SORÍ<sup>2</sup>  
GUERGANA GUEROVA<sup>3</sup>  
RAQUEL NIETO<sup>4</sup>  
EVICA STOJILJKOVIĆ<sup>5</sup>  
SRĐAN GLIŠOVIĆ<sup>6</sup>  
LUIS GIMENO<sup>7</sup>

<sup>1,2,4,7</sup> Centro de Investigación Mariña,  
Environmental Physics Laboratory  
(EPhysLab), Universidade de Vigo,  
Ourense, Spain

<sup>3</sup> Department of Meteorology and  
Geophysics, Faculty of Physics,  
Sofia University "St. Kliment  
Ohridski", Sofia, Bulgaria

<sup>5,6</sup> University of Niš,  
Faculty of Occupational Safety

<sup>1</sup>mstojanovic@uvigo.es

## DROUGHT ASSESSMENT USING GRACE TOTAL WATER STORAGE DEFICIT IN SERBIA

**Abstract:** *The frequency of natural disasters and the extent of their consequences are constantly increasing, leading to water shortages and socioeconomic losses. In this study, we estimate the drought conditions in Serbia using the terrestrial water storage anomaly data from the Gravity Recovery and Climate Experiment (GRACE) during the 2003–2016 period. Besides, the moisture sources for precipitation over Serbia were identified using the Lagrangian model FLEXPART, and their role during drought conditions was investigated. The results revealed that the most intense reduction in the moisture contribution to the precipitation over Serbia occurred from the Mediterranean Sea and terrestrial moisture sources surrounding the country. The results indicate that increased potential evapotranspiration and reduced precipitation predominated over Serbia during the drought conditions.*

**Key words:** Drought, GRACE, Lagrangian methodology, Serbia

### INTRODUCTION

Drought is a natural phenomenon characterized by lower than expected or lower than normal precipitation that, when extended over a longer period, can have an impact on various systems (e.g. economy, ecology, agriculture, etc.) [WMO, 2012]. The complexity of drought is explained by the fact that there is no universally accepted definition of drought. Concerning the field of influence, it is possible to define drought into four groups: meteorological, hydrological, agricultural, and socioeconomic drought [Wilhite and Glantz, 1985].

Meteorological drought represents reduced precipitation compared to the average precipitation over a few years. Agricultural drought referred to a period of low soil moisture, which leads to reduced crop production and plant growth. Hydrological drought represents shortages in water supply from the surface and groundwater reserves, and socioeconomic drought is based on the process of the supply and demand of some economic good with elements of all three above mention types of droughts [Dai, 2010; Zlatanovic and Stojkovic, 2016].

Although precipitation deficit is the principal cause of drought, other causes can also generate or increase droughts, such as more intense but less frequent precipitation or extremely high temperatures [Dai et al., 2010; Vicente-Serrano et al., 2012]. In recent years, several studies have investigated the origin and severity of drought in different parts of the world such as the Mediterranean region [e.g., Hoerling et al., 2012;

Xoplaki et al., 2004], Europe [Sorí et al., 2020; Stojanovic et al., 2018] Africa [Sorí et al., 2019; Stojanovic et al., 2019], and worldwide [Drumond et al., 2019], due to anomalies on the atmospheric moisture contribution to precipitation from climatological oceanic and terrestrial sources of moisture.

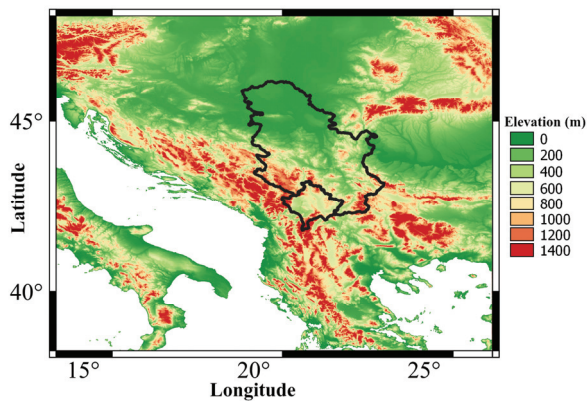
Drought has several negative effects on agriculture, water resources, environmental protection, and other human activities. In the Balkan Peninsula, as well as in the Mediterranean region and Southeast Europe, an increase in the frequency and intensity of droughts because of climate change has been observed. A similar trend is expected to continue [Kovačević-Majkić et al., 2014]. Up to now, different observational datasets show that the most severe droughts in the territory of Serbia have been recorded during the past two decades, primarily in the northeast, east and south regions [NARS 2011; Spasov 2003]. Disaster mortalities are not common while economic damage is significant. In this study, we aim to perform a similar analysis for Serbia (Figure 1). This involves the identification of hydrological drought periods based on the anomalies of the Total Water Storage Anomaly (TWSA) the identification of the most important moisture sources for precipitation in Serbia, and their role during drought conditions.

Serbia is a landlocked country located at the crossroads between Central and Southern Europe, situated in the Balkan Peninsula and Pannonian Plain. Serbia lies between latitudes 41° and 47° N, and longitudes 18°

and 23° E and the country covers a total of 88,361 km<sup>2</sup>. It shares land borders with Hungary to the north, Romania to the northeast, Bulgaria to the southeast, North Macedonia to the south, Croatia and Bosnia and Herzegovina to the west, and Montenegro to the southwest. The Danube river basin, the second largest European river, passes through Serbia (21% of its overall length) and represents the major source of freshwater.

The average altitude of Serbia is 473 m and differs in elevation between the eastern and southern parts of the country [Lukovic et al., 2015a].

Precipitation over Serbia differs widely, increasing with altitude from the north to the south of the country. Most of the country has a continental precipitation regime with maximum precipitation occurring during June and May and minimum precipitation occurring during February and October [Lukovic et al., 2015b].



**Figure 1.** The geographical location of Serbia (black line) and its elevation (in metres). Elevation data were downloaded from hydrological data and maps based on the SHuttle Elevation Derivatives at multiple Scales (HydroSHEDS) project.

The climate of Serbia is very diverse and can be classified as a warm-humid continental or humid subtropical climate. The country has the Mediterranean influence in the south and southwestern parts, while the north part of the country has characteristics of continental climate with air masses mostly coming from Northern Europe [Unkašević and Radinović, 2000].

As a result of its geographic location (Southern Europe, Balkan Peninsula), natural, and socioeconomic characteristics, Serbia is vulnerable to climate variability and climate change. It is one of few European countries with very high-risk exposure to natural hazards (e.g. droughts, floods) [Popovski, 2022; Kovačević-Majkić et al., 2014]. In this study, GRACE Total Water Storage Anomaly (TWSA) extracted in the resolution of a 1°x1° grid and implemented in the Copernicus Global Drought Observatory (GDO) is used to detect long-term hydrological drought conditions which arise when the TWS reaches values lower than usual [EDO, 2002]. Total Water Storage (TWS)

represents an important component of the hydrological cycle defined as all forms of water above and beneath the surface of the Earth. It represents an aggregation of the quantities of groundwater, soil moisture, surface water, snow, ice, and vegetation water content. The ability to obtain information below the first several centimetres of the land surface is what makes GRACE so important for hydrological research and the identification of drought events [Mirceva et al., 2020]. After identification of the drought events, the anomalies in the moisture contribution to precipitation, precipitation (PRE) and potential evapotranspiration (PET) during these drought events were calculated and analysed.

## DATASETS AND METHODOLOGY

### - Datasets

Monthly precipitation (PRE) and atmospheric evaporative demand (AED) values were obtained using the current version of the Climatic Research Unit (CRU) Time-Series [Harris et al., 2020] for the period 2003 – 2016.

Monthly Total Water Storage Anomaly (TWSA) was extracted with 1°x1° grid resolution for the period 2003 – 2016 from the Gravity Recovery and Climate Experiment (GRACE) mission available at the Copernicus Global Drought Observatory (GDO).

Monthly global outputs from the FLEXPART model (FLEXPART) v9.0 model [Stohl and James, 2004,2005], available at the Environmental Physics Laboratory (EphysLab) of the University of Vigo, Spain, were used for the period of study (2003 – 2016). FLEXPART uses as input data the global ERA-Interim reanalysis database from the European Centre for Medium-Range Weather Forecasts in a horizontal resolution of 1°x1° on 61 vertical levels, ranging from 1000 to 0.1 hPa [Dee et al., 2001].

### - GRACE total water storage

The gravity recovery and climate experiment (GRACE) space mission was launched in March 2002 and developed by the National Aeronautics and Space Administration (NASA) and the German Research Center for Geosciences (GFZ). This mission aimed to measure variations in the terrestrial gravity field [Tapley et al., 2004]. It consists of two identical satellites placed 220 km apart on a near-polar orbiting at an altitude of approximately 450–500 km. The satellites are linked with a very precise microwave system, which measures the variation in the distance between the satellites. These measurements are used to compute satellite trajectories and monthly gravity field solutions in a common orbit and force a model parameter estimation process. A GRACE follow-up mission was successfully launched in May 2018 and is equipped with an innovative laser-ranging



interferometer to improve measurement precision, and it is currently operational.

Recently, remote sensing has been shown to be suitable for accurately understanding regional variations and patterns of drought-related parameters [Thomas 2014]. Previous studies showed that drought events can be accurately monitored using the GRACE TWS at regional scales [Sun 2018; Zhao 2018], therefore it is a powerful method for quantifying and characterizing drought events on a regional scale.

The GRACE satellite measures provide inimitable insights into the hydrological state of river systems with regard to their TWS (Frappart and Ramillien, 2018). The TWS represents the sum of all above and below surface water storage, including canopy water, rivers and lakes, soil moisture, and groundwater, and it represents a synthetic proxy of the dynamic of slow-responding hydrological quantities. The TWS is used to calculate the anomaly from the climatological reference period (2002-2018). The TWS Anomaly is an indicator usually used to detect and monitor long-term hydrological drought, which complements more fast-responding indicators, such as soil moisture and streamflow droughts. There are approximately 20 months of data that were missed and all missing data were interpolated using the mean values before and after the missing month.

- **The Standardised Precipitation Index (SPI) and the Standardised Precipitation-Evapotranspiration Index (SPEI)**

The SPI (Mckee et al., 1993) and SPEI were calculated with datasets of PRE and PRE and AED, respectively. Both the SPI and SPEI are multiscale drought indices widely implemented for monitoring and investigating droughts. At a 12-months temporal scale, both have been associated with hydrological drought.

- **FLEXible PARTicle dispersion model (FLEXPART)**

For the outputs here utilised the model FLEXPART considered the atmosphere divided into approximately 2.0 million of air particles with a constant mass ( $m$ ), which are transported using 3D wind fields. Changes in the specific humidity ( $q$ ) and the position of the particles were documented for each air parcel every 6 hours. In every step, the  $q$  changes are assumed as the budget of evaporation ( $e$ ) minus the precipitation ( $p$ ) in the parcel. By integrating the  $(e - p)$  values for all parcels residing in the atmospheric column it is possible to estimate the total budget of atmospheric humidity ( $E - P$ ), where  $E$  represents evaporation and  $P$  represents precipitation.

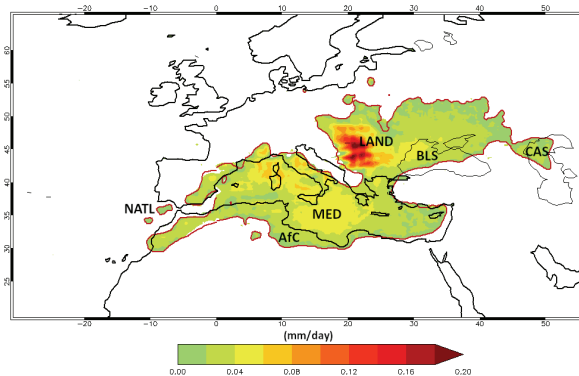
In the backward experiment those regions where air masses gained moisture rather than lose ( $(E - P) > 0$ ), were considered sources of moisture. The forward analysis performed from the sources is used to compute their moisture contribution to the precipitation ( $(E - P)$

$< 0$ ) over the entire of Serbia. The optimum integration time used for identifying the sources and afterward calculating the budget of  $(E - P) < 0$  over Serbia was calculated using the Nieto and Gimeno (2019) dataset, being 10 days.

To determine the anomalous contribution from the moisture sources to Serbia, drought conditions according to TWSA, were obtained.

**RESULTS**

We tracked the air masses residing over Serbia backward in time to identify the climatological moisture sources for the period 2003-2016 (Figure 2). The positive values of  $(E-P) > 0$  (reddish colours), means that evaporation exceeds precipitation in the net moisture budget and this allows us to identify moisture sources. According to the threshold of 0.0075 mm/day, which corresponds to the 95% percentile of the annual averages of  $(E-P) > 0$  obtained from the backward experiment, Serbia mainly receives moisture from 4 oceanic and 3 terrestrial moisture source regions: North Atlantic Ocean (NATL), Mediterranean Sea (MED), Black Sea (BLS), Caspian Sea (CAS), African continent (AFC), Serbia itself and terrestrial moisture sources surrounding the country (hereafter LAND). These regions are shown in Figure 2.

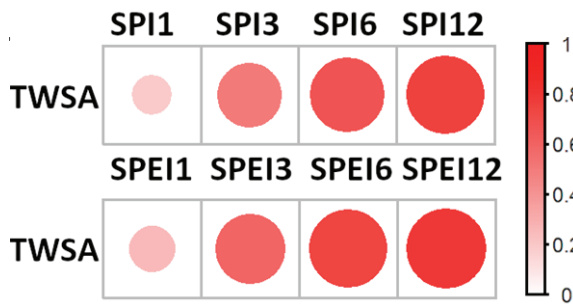


**Figure 2.** Climatological annual moisture sources obtained using the backward experiment for Serbia during the period 2003-2016. The red contour line delimits the source areas selected using the 95 percentile of the  $(E-P) > 0$  values (i.e., 0.0075 mm/day, respectively).

Figure 3 presents the correlation analysis between the series of TWSA and the corresponding series of SPI and SPEI at temporal scales of 1, 3, 6, and 12 months. It reveals that TWSA is best correlated with SPI 12 and SPEI 12 (0.77, 0.80 respectively) while the lower correlation is found with SPI 1 and SPEI 1 (0.19, 0.26 respectively). This is in agreement with Cammalleri et al. (2019) who explained that TWSA is well correlated with long-term SPI time scales. This suggests that TWSA can be used to obtain long-term hydrological drought, such as the ones observable in groundwater storage. Thus, TWSA anomalies can be used to detect the presence of potential long-term hydrological drought conditions. Details on the comparison between

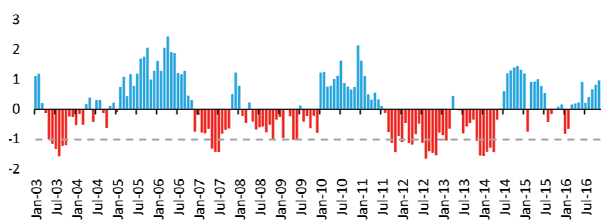


this dataset and multiple timescales SPI can be found in Cammalleri et al. (2019).



**Figure 3.** Pearson correlation values obtained over Serbia between the time series of TWSA and SPI and SPEI

Figure 4 represents the time series of GRACE TWSA. It is used as an indicator for determining the occurrence of long-term hydrological drought conditions, which arise when the TWSA reaches values lower than -1 (grey dashed line (Figure 4)). According to this, it can be noted that the months of June-October 2003, May-July 2007, October-November 2011, March-April 2012, July-November 2012, and November 2013-April 2014 (shown in Table 1) represent the months of hydrological drought conditions.



**Figure 4.** Time series of GRACE Total Water Storage (TWS) anomaly. The grey dashed line shows values less than -1 which represent drought conditions.

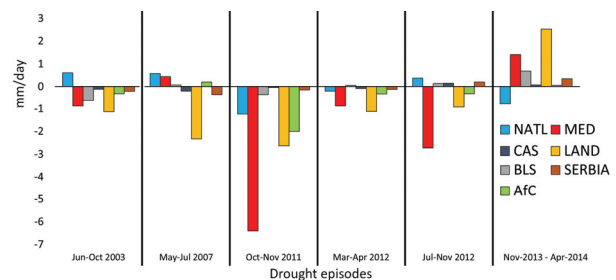
**Table 1.** The months of different years with TWS anomaly values with drier than normal conditions

First month	Last month	Duration (months)
June 2003	October 2003	5
May 2007	July 2007	3
October 2011	November 2011	2
March 2012	April 2012	2
July 2012	November 2012	5
November 2013	April 2014	6

Monthly anomalies of moisture contribution to precipitation ( $E - P < 0$ ) over Serbia obtained using the forward analysis from every source during drought conditions (Table 1) are shown in Figure 5. From June to October 2003, the moisture contribution to Serbia from all sources was reduced except from the NATL. From May to July 2011 the most prominent reduction on the contribution from the sources occurred from the

terrestrial moisture source (LAND), while there was a small increase in the moisture contribution from the NATL, MED, and AfC while the rest of the sources showed negative anomalies in the moisture contribution with the highest negative anomaly from. During the hydrological drought episode that occurred from October 2011 to November 2011, all sources experienced a decline in the moisture contribution to the precipitation over Serbia. The highest negative moisture contribution was identified from the Mediterranean source (MED).

The summer of 2012 was the hottest and third driest on record in Serbia [12]. According to this, we identified 2 periods of dry conditions in Serbia, the period from March 2012 to April 2012 and from July to November of the same year. During the period March – April 2012, a reduction in the moisture contribution to precipitation from all of the sources was also notable. During the period July – November 2012, a reduction in the moisture contribution occurred from 3 moisture sources (MED, LAND, AfC) while the rest of the sources showed positive values. During the drought identified from November 2013 to April 2014, only the NATL experienced a reduction in moisture contribution. During all of these dry periods identified during 2003 – 2016 negative anomalies of PRE and positive anomalies of PET prevailed (Table 2).



**Figure 5.** Monthly anomalies of moisture contribution to precipitation ( $E - P < 0$ ) over Serbia during drought conditions in the period 2003-2016.

**Table 2.** Precipitation (PRE) and Potential evapotranspiration (PET) anomalies during drier than normal conditions identified using GRACE TWSA

First month	Last month	PRE	PET
June 2003	October 2003	-3.93	6.0
May 2007	July 2007	-11.25	12.56
October 2011	November 2011	-36.3	-0.05
March 2012	April 2012	-5.0	6.37
July 2012	November 2012	-19.39	12.77
November 2013	April 2014	-10.48	2.08

## CONCLUSION

We identified and analysed hydrological drought conditions in Serbia during the period 2003 – 2016,

based on GRACE Total Water Storage Anomaly data. In this period were recorded 6 drought events. Correlating this data with SPI and SPEI on different scales, the highest correlation was found with SPI12 and SPEI12 (0.77, 0.80 respectively). The Total Water Storage Anomaly data provided considerable insights into the field of hydrology, revealing information about large-scale groundwater depletion and droughts. Besides, the sources of moisture over Serbia using a Lagrangian approach were identified, revealing that Serbia mainly receives moisture from 4 oceanic and 3 terrestrial moisture source regions: North Atlantic Ocean, Mediterranean Sea, Black Sea, Caspian Sea, the African continent, Serbia itself, and terrestrial moisture sources surrounding the country. The anomalies in the contribution from these sources to the precipitation over Serbia confirmed an intense reduction in the moisture contribution from the Mediterranean Sea and the terrestrial moisture sources surrounding the country, which were associated with increased potential evapotranspiration, and the reduction of precipitation.

## REFERENCES

- Dai, A. (2010). Drought under global warming: A review. *WIREs Clim. Chang.* 2, pp. 45–65.
- Dee, D.P., Uppala, S.M., Simmons, A.J., Berrisford, P., Poli, P., et al. (2001). “Configuration and performance of the data assimilation system”, *Quarterly Journal of the Royal Meteorological Society*, 137, pp. 553–597. <https://doi.org/10.1002/qj.828>
- Drumond, A., Stojanovic, M., Nieto, R., Vicente-Serrano, S.M., Gimeno, L. (2019). Linking Anomalous Moisture Transport and Drought Episodes in the IPCC Reference Regions, *Bulletin of the American Meteorological Society*, pp.1-54, <https://doi.org/10.1175/BAMS-D-18-0111.1>
- European and Global Drought Observatories, EDO (2002). GDO GRACE Total Water Storage Anomaly (version 1.1.0). European Commission, Joint Research Centre (JRC) [Dataset] PID: <http://data.europa.eu/89h/0fd62e28-241f-472c-8966-98744920e181>
- Frappart, F., Ramillien, G. (2018). Monitoring groundwater storage changes using the gravity recovery and climate experiment (GRACE) satellite Mission: a review. *Remote Sensing* 10, pp. 1–25. <https://doi.org/10.3390/rs10060829>
- Harris, I., Osborn, T.J., Jones, P. et al. (2020). Version 4 of the CRU TS monthly high-resolution gridded multivariate climate dataset. *Sci Data* 7, 109. <https://doi.org/10.1038/s41597-020-0453-3>
- Hoerling, M., Eischeid, J., Perlwitz, J., Quan, X., Zhang, T. and Pegion, P. (2012). On the increased frequency of Mediterranean drought. *J. Clim.*, 25(6), pp. 2146 – 2161. <https://doi.org/10.1175/JCLI-D-11-00296.1>
- Cammalleri, C., Barbosa, P., Vogt, J.V. (2019). Analysing the Relationship between Multiple Timescale SPI and GRACE Terrestrial Water Storage in the Framework of Drought Monitoring. *Water* 11(8), 1672. <https://doi.org/10.3390/w11081672>
- Kovačević-Majkić, J., Panić, M., Miljanović, D. et al. (2014). Vulnerability to natural disasters in Serbia: spatial and temporal comparison. *Nat Hazards* 72, pp. 945–968. <https://doi.org/10.1007/s11069-014-1045-3>
- Luković, J., Blagojević, D., Kilibarda, M., Bajat, B. (2015a). “Spatial pattern of North Atlantic oscillation impact on rainfall in Serbia”, *Spatial Statistics*, 14, pp. 39-52
- Luković, L., Bajat, B., Kilibarda, M., Filipović, D. (2015b). “High resolution grid of potential incoming solar radiation for Serbia”, 19, pp. S427-S435.
- Mircheva, B., Tsekov, M., Meyer, U., Guerova, G. (2020). Analysis of the 2014 Wet Extreme in Bulgaria: Anomalies of Temperature, Precipitation and Terrestrial Water Storage. *Hydrology*, 7, 66. <https://doi.org/10.3390/hydrology7030066>
- National Assembly of the Republic of Serbia (2011) The National Strategy on Protection and Rescue in Emergency Situations. Belgrade. <https://www.seesac.org/f/tmp/files/failovi/389.pdf>
- Nieto, R., Gimeno, L. (2019). A database of optimal integration times for Lagrangian studies of atmospheric moisture sources and sinks, *Scientific Data*, 6, pp.1-10. <https://doi.org/10.1038/s41597-019-0068-8>
- Popovicki, T. (2022). Enhancing Nature-based Solutions in Serbia: the role of ecosystems in disaster risk reduction and climate change adaptation. Gland, Switzerland: IUCN. <https://portals.iucn.org/library/efiles/documents/2022-008-En.pdf>
- Stohl A. and James, P. (2004). A Lagrangian analysis of the atmospheric branch of the global water cycle. Part I: Method description, validation, and demonstration for the August 2002 flooding in central Europe. *J. Hydrometeorol.*, 5, 656–678. [https://doi.org/10.1175/1525-7541\(2004\)005<0656:ALAOTA>2.0.CO;2](https://doi.org/10.1175/1525-7541(2004)005<0656:ALAOTA>2.0.CO;2)
- Stohl, A. and James, P. (2005). A Lagrangian analysis of the atmospheric branch of the global water cycle. Part II: Moisture transports between the Earth’s ocean basins and river catchments. *J. Hydrometeorol.*, 6, 961–984. <https://doi.org/10.1175/JHM470.1>
- Stojanovic, M., Drumond, A., Nieto, R., Gimeno, L. (2018). Anomalies in Moisture Supply during the 2003 Drought Event in Europe: A Lagrangian Analysis, *Water*, 10(4), 467, pp. 1-19. doi:10.3390/w10040467
- Stojanovic, M., Drumond, A., Nieto, R., Gimeno, L. (2018). Variations in Moisture Supply from the Mediterranean Sea during Meteorological Drought Episodes over Central Europe, *Atmosphere*, 9, pp. 1-15 doi:10.3390/atmos9070278
- Sorí, R., Nieto, R., Drumond, A., Stojanovic, M., Gimeno, L. (2019). On the Connection between Atmospheric Moisture Transport and Dry Conditions in Rainfall Climatological Zones of the Niger River Basin, *Water*, 11(3), pp. 1-20 <https://doi.org/10.3390/w11030622>
- Sorí, R., Vázquez, M., Stojanovic, M., Nieto, R., Liberato, M.L.R., Gimeno, L. (2020). Hydrometeorological droughts in the Miño–Limia–Sil hydrographic demarcation (northwestern Iberian Peninsula): the role of atmospheric drivers, *Natural Hazards and Earth System Sciences*, 20, 6, pp. 1805–1832, <https://doi.org/10.5194/nhess-20-1805-2020>
- Spasov, P. (2003). Pojava suse u Srbiji, njeno pracenje i mogucnosti prognoze (Drought occurrences in Serbia,

monitoring and forecasting possibilities). *Vodoprivreda* 35, pp.30–36.

<https://www.vodoprivreda.net/wp-content/uploads/2014/08/pojava-suse-2003.pdf>

Sun, Z., Zhu, X., Pan, Y., Zhang, J., Liu, X. (2018). Drought evaluation using the GRACE terrestrial water storage deficit over the Yangtze River Basin, China. *Sci. Total Environ.* 634, 727–738. DOI: 10.1016/j.scitotenv.2018.03.292

Tapley, B.D., Bettadpur, S., Ries, J.C., Thompson, P.F., Watkins, M.M. (2004). GRACE measurements of mass variability in the Earth System. *Science*, 305, pp. 503–505. DOI: 10.1126/science.1099192

Thomas, A.C., Reager, J.T., Famiglietti, J.S., Rodell, M.A. (2014). GRACE based water storage deficit approach for hydrological drought characterization. *Geophys. Res. Lett.* 41, pp. 1537–1545. <https://doi.org/10.1002/2014GL059323>

Unkašević, M., Radinović, Đ. (2000). “Statistical analysis of daily maximum and monthly precipitation at Belgrade”, *Theoretical and Applied Climatology*, 66, pp. 241-249.

Vicente-Serrano, S.M., Gouveira, C., Camarero, J.J., Beguería, S., Trigo, R., Lopez Moreno, J.I., Azorin-Molina, C., et al. (2012). Drought Impacts on Vegetation Activity, Growth and Primary Production in Humid and Arid Ecosystems. 2012. Available online: [http://digital.csic.es/bitstream/10261/62153/1/BegueriaS\\_Drought\\_ComCongSal-AEC\\_2012.pdf](http://digital.csic.es/bitstream/10261/62153/1/BegueriaS_Drought_ComCongSal-AEC_2012.pdf) (accessed on 24 August 2022)

Wilhite, D.A., Glantz, M.H. (1985). Understanding the Drought Phenomenon: The Role of Definitions. *Water Int.* 10, pp.111–120.

World Meteorological Organization. Drought Monitoring and Early Warning: Concepts, Progress and Future Challenges. 2006. Available online: <http://www.wamis.org/agm/pubs/brochures/WMO1006e.pdf> (accessed on 24 August 2022).

Xoplaki, E., Gonzalez-Rouco, J. F., Luterbacher, J., and Wanner, H. (2004). Wet season Mediterranean precipitation variability: influence of large-scale dynamics and trends, *Clim. Dynam.*, 23, pp. 63–78.

Zlatanovic, N., Stojkovic, M. (2016). Assessment and monitoring of droughts in Southeastern Europe: A Review. *Water Res. Man.* 6, pp.11–18.

Zhao, C., Huang, Y., Li, Z., Chen, M. (2018). Drought Monitoring of Southwestern China Using Insufficient GRACE Data for the Long-Term Mean Reference Frame under Global Change. *J. Clim.* 31, pp. 6897–6911. <https://doi.org/10.1175/JCLI-D-17-0869.1>

## ACKNOWLEDGEMENTS

This work received financial support from the LAGRIMA and SETESTRELO projects (Grants RTI2018-095772-B-I00 and PID2021-122314OB-I00, respectively) granted by the Ministerio de Ciencia, Innovación y Universidades, Spain. Partial support was also obtained from the Autonomous Government Xunta de Galicia-FEDER under projects ED431C 2021/44 (Grupos de Referencia Competitiva): “ERDF A way of making Europe.” Milica Stojanovic, and Rogert Sorí were supported by the Xunta of Galicia under grants ED481B-2021/134 and ED481B 2019/070.

## BIOGRAPHY of the first author

**Milica Stojanović** was born in Leskovac, Serbia, in 1990. She holds a Master’s degree in Environmental Engineering, from the University of Nis, Faculty of Occupational Safety, Nis, Serbia. She finished her PhD studying anomalies in moisture transport



during most severe drought episodes at the University of Vigo in Spain. The main areas of her research include environmental science, the global water cycle, and the impact of climate change on hydrology. Currently, she is a postdoctoral researcher at the University of Vigo, Spain.

ANA BIJELIĆ<sup>1</sup>  
TATJANA GOLUBOVIĆ<sup>2</sup>  
MARINA STOJANOVIĆ<sup>3</sup>

<sup>1,2,3</sup>University of Niš,  
Faculty of Occupational Safety

<sup>1</sup>ana.miltojevic@znrfak.ni.ac.rs  
<sup>2</sup>tatjana.golubovic@znrfak.ni.ac.rs  
<sup>3</sup>marina.stojanovic@znrfak.ni.ac.rs

## THE USE OF SAFER SOLVENTS – ONE OF 12 PRINCIPLES OF GREEN CHEMISTRY

**Abstract:** Organic solvents are carbon-based substances, capable of dissolving or dispersing one or more other substances. They have wide applications, i.e. they are constituents of many products (e.g. dyes, paints, polymers, agricultural and pharmaceutical products, cleaning agents, etc.) and are used in many industries, as well as in organic chemistry. Not only that the majority of classical organic reactions occur in solvents, but they are also used for extraction, isolation, and purification. The production of organic solvents is estimated at several million metric tons and is worth more than tens of billions of US dollars, annually. As many organic solvents are considered to be carcinogens, reproductive hazards, and neurotoxins, their use should be avoided whenever possible. According to the United States Environmental Protection Agency (US EPA), green chemistry is defined as “the design of chemical products and processes that reduce or eliminate the use or generation of hazardous substances”. As it is based on the concept of sustainability, it is also called sustainable chemistry and it applies across the life cycle of a chemical product, including its design, manufacture, use, and disposal. (Re)Designing products and manufacturing processes, to reduce their impact on human health and the environment, is the main goal of green chemistry. Green chemistry is based on 12 basic principles and one of them is the use of safer solvents and other auxiliary chemicals. Greener alternatives to classical solvents, that are being integrated into chemical synthesis and industrial processes, include renewable solvents and so-called neoteric solvents, such as ionic liquids, deep eutectic solvents, liquid polymers, supercritical carbon dioxide, gas expanded solvents, and switchable solvents. Having in mind before mentioned, in this paper the fifth principle of green chemistry, concerning the use of safer solvents and auxiliaries, will be discussed and an overview of green solvents will be given.

**Key words:** safer solvents, renewable solvents, ionic liquids, deep eutectic solvents

### INTRODUCTION

Green chemistry (GC) is an area of chemistry and chemical engineering focused on the design of chemical products and processes that reduces or eliminates the use or generation of hazardous substances (EPA, 2022). As it is based on the concept of sustainability, it is also called sustainable chemistry. The principal goal of GC is (re)designing products and manufacturing processes, to reduce their impact on human health and the environment. GC applies across the life cycle of a chemical product, including its design, manufacture, use, and ultimate disposal (EPA, 2022).

The roots of green chemistry can be found in the US Federal Pollution Prevention Act of 1990. During the early 1990s US EPA coined the phrase “green chemistry” when Paul Anastas known as “the father of green chemistry”, along with John Warner, postulated

12 basic principles of GC (Anastas and Warner, 1998; Lancaster, 2002), that are listed below:

1. Waste prevention: It is better to prevent waste, i.e. during chemical synthesis, rather than to treat it or clean it up.
2. Maximization of atom economy: Processes, i.e. syntheses, should be designed to maximize the incorporation of all starting materials into final products, to waste as few atoms as possible, or even better, no atoms at all.
3. Less hazardous chemical syntheses: Syntheses should be designed to use and generate substances with little or no toxicity to humans and/or the environment.
4. Designing safer chemicals and products: Chemical products should be designed to have a certain function, but with little or no toxicity.



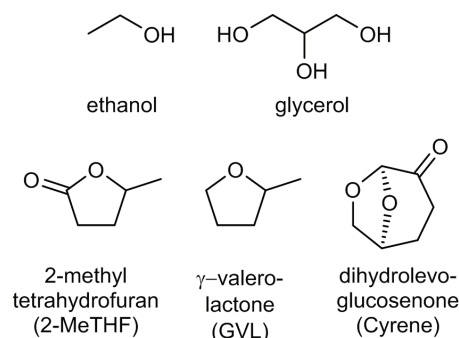
5. Safer solvents: The use of solvents, separation agents, or other auxiliary chemicals should be avoided whenever possible; if their use is inevitable, safer solvents should be used.
6. Energy efficiency: Environmental and economic impact of chemical reactions should be reduced to a minimum, i.e. if possible, reactions should be run at room temperature and pressure.
7. Renewable feedstocks (starting materials): Renewable feedstocks (i.e. agricultural products or the waste generated in some other process) should be used rather than the depletable ones (i.e. fossil fuels).
8. Derivatisation and modification reduction: Blocking and protecting groups, or any temporary modifications, should be reduced to a minimum, as they require additional reagents and generate waste.
9. Catalysts: The waste can be minimized by using catalytic reactions instead of stoichiometric reagents.
10. Design chemicals and products to degrade after use: Chemicals and products should be designed to degrade to safe substances after use.
11. Real-time analysis for pollution prevention: Real-time monitoring and pollution control should be done during syntheses to minimize or eliminate the formation of byproducts.
12. Safer chemicals for accident prevention: Chemicals and their physical forms (solid, liquid, or gas) used in chemical processes should be chosen to minimize the potential for chemical accidents (explosions, fires, and releases into the environment).

Organic solvents are carbon-based substances, i.e. hydrocarbons, amines, esters, ethers, ketones, nitrated or chlorinated hydrocarbons, capable of dissolving or dispersing one or more other substances (CDC, 2022). They have been widely applied in many industries and in organic chemistry, i.e. synthesis (the most classical chemical reactions occur in solvents) and in the process of extractions, isolation, and purification of substances. Moreover, they are constituents of many products (dyes, paints, glues, cleaning agents, polymers, plastics, agricultural products, pharmaceuticals, etc.). The annual production of organic solvents is estimated to be *ca.* 20 million tonnes and is worth tens of billions of US dollars annually to the global economy (Clark et al., 2015). In Europe, solvent manufacturers produce 5 million tonnes of solvents annually, contributing 4 billion euros to Europe's economy (ESIG, 2022). Because many organic solvents have been recognized as carcinogens, reproductive hazards, and neurotoxins, human and environmental exposure to them should be reduced to a minimum (Sansom, 2018). Having in mind before mentioned, in this paper the fifth principle of green chemistry will be discussed and an overview of green sustainable solvents will be given, to help researchers to choose solvents that have low environmental, safety, and health impacts, discouraging the use of toxic, harmful solvents. Greener alternatives to classical solvents include renewable solvents and so-

called neoteric solvents, such as ionic liquids, deep eutectic solvents, liquid polymers, supercritical carbon dioxide, gas expanded solvents, and switchable solvents (Clarke et al., 2018).

## RENEWABLE SOLVENTS

Renewable solvents, as well as renewable chemicals in general, are substances obtained from plant biomass, particularly crops, grasses, agricultural residues, and agroforestry products (Clarke et al., 2018). The major components of biomass are starch and cellulose, biopolymers composed of glucose units joined by glycosidic bonds, that can be hydrolyzed, chemically or enzymatically, to glucose. Subsequent chemical transformations of glucose can provide a wide range bio-derived solvents, i.e. bioethanol, glycerol, 2-methyl tetrahydrofuran (2-MeTHF),  $\gamma$ -valerolactone (GVL), dihydrolevoglucosenone (Cyrene) (Fig. 1). Their properties have been extensively investigated (Clarke et al., 2018, and references cited therein).



**Figure 1.** Structures of some renewable solvents

Several biofuels can be used as renewable solvents, for example, bioethanol. Generally, biofuels have been roughly classified into two classes, first- and second-generation biofuels. First-generation biofuels are produced primarily from food crops such as corn, grains, sugar cane, and vegetable oils, but the production of fuels from food crops opened a debate if those raw materials should be used for the production of chemicals rather than for food (Clarke et al., 2018). Second-generation biofuels are produced from renewable feedstocks that are not used for food, i.e. from cellulosic biomass, grasses such as miscanthus and willow, agricultural residues (wheat straw), and lignocellulosic biomass, such as agroforestry products (timber, woody biomass) (Mohr and Raman, 2013). That is why they represent a sustainable response to the increasing controversy surrounding first-generation biofuels but their major disadvantage is higher energy consumption, as well as higher production costs (Mohr and Raman, 2013).

Bioethanol can be used in place of synthetic ethanol for many types of industrial and laboratory applications, including synthesis. The main benefits of using bioethanol are that it is produced from corn, a renewable raw material, that reduces the use of petrochemicals for the production of ethanol, and that the production methods are safer for the environment



(Merck, 2022). Moreover, bioethanol is ethanol of high quality, with a price comparable to conventional petrochemical-based ethanol.

Glycerol, a non-toxic, biodegradable, and recyclable liquid manufactured from renewable sources is another alternative green solvent for organic reactions. It is worth mentioning that large quantities of glycerol are generated by the biodiesel industry (ca. 10% of the total output). It can be successfully employed as a solvent in organic reactions as it dissolves a variety of reactants and catalysts and enables easy separation of the products. Glycerol allows the dissolution of inorganic salts, acids, and bases, as well as enzymes and transition metal complexes, but it also dissolves organic compounds that are poorly miscible in water and it is non-hazardous (Wolfson et al., 2007).

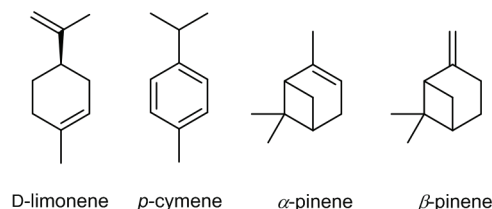
Similar to bioethanol, 2-methyl tetrahydrofuran (2-MeTHF) was originally planned to be used as a biofuel, but today it is used as a renewable alternative to THF (Pace et al., 2012). In comparison to THF, 2-MeTHF has lower water miscibility, higher stability, and lower volatility, as well as lower toxicity, with high flammability as the main disadvantage (Prat et al., 2016).

$\gamma$ -Valerolactone (GVL) has become a popular bio-derived chemical that may be used as a renewable fuel or solvent. It is a colorless water-soluble liquid, it is stable and does not decompose at room temperature, but has high vapor pressure. GVL is a sustainable alternative to toxic dipolar aprotic solvents such as acetonitrile, dimethylformamide (DMF), or *N,N*-dimethylacetamide (DMA) (Strappaveccia et al., 2015). The major disadvantage of GVL is that industrial-grade GVL may contain mineral acid as a contaminant, from the pretreatment process, which can catalyze the opening of the GVL ring to 4-hydroxyvaleric acid, which may chelate metals. Moreover, GVL reacts with water at temperatures higher than 100 °C, thus it can not be used as a solvent at high temperatures in the presence of water. Additionally, its industrial application is limited due to high production costs (Clarke et al., 2018).

Another solvent that can be obtained from cellulose is dihydrolevoglucosenone, Cyren, which has been proposed as a replacement for toxic polar aprotic solvents such as *N*-methyl-2-pyrrolidone (NMP), cyclohexanone, dimethylformamide (DMF), dimethylacetamide (DMAc), dimethyl sulfoxide (DMSO), and sulfolane. Dispersion properties of Cyrene are most similar to those of DMSO, its polar interactions are most similar to those of DMAc, while its hydrogen bond interactions are similar to NMP (Clarke et al., 2018).

Theoretically, limonene and some other terpenes,  $\beta$ -pinene,  $\alpha$ -pinene, *p*-cymene (Fig. 2) can be considered renewable solvents as they can be obtained from citrus waste. For example, limonene obtained in this way can replace toxic solvents such as fossil fuel-derived toluene in the industrial cleaning sectors. But there are

many assumptions about the production of these compounds from citrus waste and there are some concerns about the inherent complexity and uncertainty of their production due to economic and technological factors. Moreover, some terpenes, D-limonene,  $\beta$ -pinene,  $\alpha$ -pinene, *p*-cymene, have recently been identified as high-risk solvents for environmental emissions due to their moderate inhalation toxicities and high photochemical ozone creation potentials (POCPs) (Clarke et al., 2018).

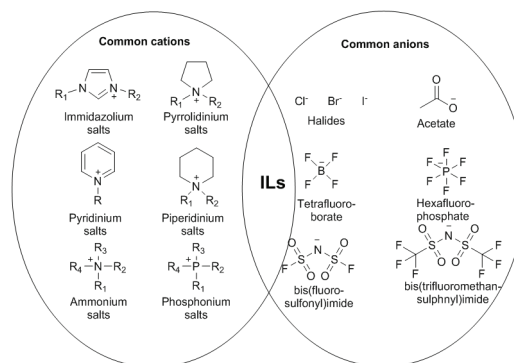


**Figure 2.** Terpenes that can be considered renewable solvents produced from citrus waste

## IONIC LIQUIDS

Ionic liquids (ILs) are liquid salts comprised entirely of cations and anions with melting points at, or close to, room temperature (Clarke et al., 2018) or according to some authors below 100 °C (Lei et al., 2017). The main difference between ILs and common salts, e.g. NaCl, is the low melting point of ILs (common salts have melting points higher than 800 °C). The low melting points of ILs are due to the bulkiness and unsymmetry of their constituent ions (Greer et al., 2020). In comparison with traditional solvents, ILs are thermally more stable, and less flammable due to their low vapor pressure at ambient temperature. Moreover, they have higher thermal and electrical conductivities as they are comprised of ions (Greer et al., 2020). As ILs have high chemical and thermal stabilities, low volatility, and remarkable solvating power, they were popularised as green solvents. However, their high chemical and thermal stabilities make them persistent environmental pollutants, especially in aquatic environments (Clarke et al., 2018).

Aprotic ionic liquids are traditionally made by nucleophilic substitution reactions of amines or phosphines with alkylhalides or alkylsulfates in an inert atmosphere (Fig. 3).



**Figure 3.** Common cations and anions for ionic liquids

The synthesis of ILs is relatively slow (depending on reagents) and requires solvent-demanding purifications (i.e. recrystallization). Some alternative solvent-free syntheses of ILs have been published (Clarke et al., 2018). Over the last few decades, the production of ILs on an industrial scale has increased. Industrial-scale production of ILs is based mostly upon simple, well-known salts, and depends on the availability of starting materials and the cost.

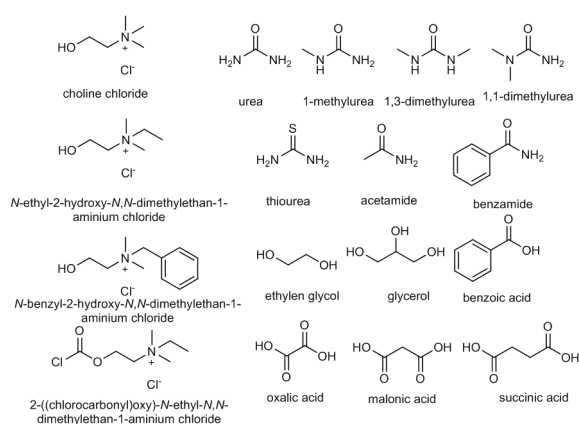
“Air and moisture stable” ILs are viable alternatives to conventional organic solvents in academic, as well as industrial applications. In industry, ILs can only be applied if sustainable and scalable synthesis procedures exist and in bulk solvent (dissolution/extraction/separation), catalytic (hydroformylation/alkylation), additive (anti-statics/dispersing agents), and electrochemical (electrolytes for batteries/electrodeposition) technologies (Greer et al., 2020). A major challenge and a significant barrier to their industrial application are complicated synthetic routes that require hardly available and expensive starting materials (aprotic ionic liquids require lengthy preparations from expensive starting materials), as well as toxic or non-renewable reagents. On the other hand, ILs with simpler synthetic routes may face issues such as high acidity, thus may cause corrosion (Greer et al., 2020; Clarke et al., 2018). For the successful industrial application of ILs, their recyclability, reusability, routes of disposal, and toxicity should be evaluated in more detail. Renewable and bio-derived ILs are promising solvents in biorefinery and some strategies for increasing their biodegradability have been developed (Clarke et al., 2018).

## DEEP EUTECTIC SOLVENTS

A new class of green solvents related to ILs is deep eutectic solvents (DESs). These are binary or ternary mixtures comprising at least one hydrogen bond donor and at least one hydrogen bond acceptor, strongly associated with hydrogen bond interactions, that contributes to the decrease of the lattice energy of the system, lowering the melting point of the mixture (Perna et al., 2020). Thus, DESs are eutectic mixtures of Lewis or Brønsted acids and bases with the general formula  $Cat^+ X^- zY$ , where  $Cat^+$  is in principle any ammonium, phosphonium, or sulfonium cation,  $X^-$  is a Lewis base, generally a halide anion,  $Y$  is Lewis or Brønsted acid, while  $z$  refers to the number of  $Y$  molecules that interact with the anion (Fig. 4). The complex anionic species are formed between  $X^-$  and  $Y$  (Smith et al., 2014). Depending on their constituents, they are classified into four subclasses (Smith et al., 2014).

DESs are typically easy to prepare, most usually by heating and stirring the constituents of the DES together under an inert atmosphere until a homogeneous liquid is formed, where no additional solvent is needed. There is no reaction in the traditional

sense nor the purification steps are needed, making them more economically viable than conventional organic solvents and ILs. DESs are typically viscous, clear liquids, they exhibit thermal transition characteristics. Many DES compounds readily undergo both crystallization and/or glass transitions depending principally on their constituent makeup and cooling rates (Hansen et al., 2021). DESs and conventional ILs have different chemical, but similar physical properties, i.e. generally high thermal stabilities, low volatility, low vapor, pressures, tunable polarity, relatively wide liquid range, and nonflammability (Hansen et al., 2021; Smith et al., 2014). Moreover, in comparison to ILs, DESs are nontoxic, biodegradable, inexpensive, easier to prepare, and less expensive which makes them economically viable alternatives to conventional organic solvents and ILs (Hansen et al., 2021).



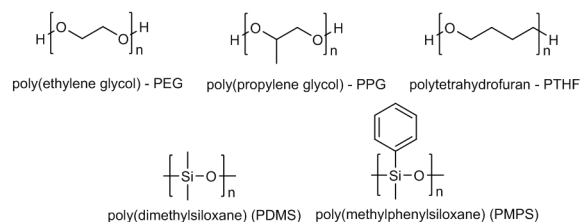
**Figure 4.** Hydrogen-bond acceptors and donors for deep eutectic solvents

Two major application areas of DESs are metal processing and chemical synthesis. In metal processing, DESs are applied for the incorporation of metal ions in solution for metal deposition, metal dissolution, as well as in metal finishing industry (Smith et al., 2014). Smith and co-workers gave major advantages of using DESs over aqueous electrolytes, i.e. the high solubility of metal salts, the absence of water, and high conductivity compared to nonaqueous solvents. Additionally, DESs have recently been proposed as environmentally friendly solvents for synthesis, i.e. ionothermal synthesis, gas adsorption, biotransformations, transformations of unprotected sugars, cellulose, and starch, as well as in purifying and manufacturing biodiesel (Smith et al., 2014).

## LIQUID POLYMERS

Liquid polymers (LPs) are another class of nontoxic green solvents with the inherent advantage of negligible volatility. The polymers most commonly studied are poly(ethylene glycol) (PEG), poly(propylene glycol) (PPG), poly(tetrahydrofuran) (PTHF), poly(dimethylsiloxane) (PDMS), and poly(methylphenylsiloxane) (PMPS) (Fig. 5). Their main advantages, in comparison to ILs and some DESs, are the following: they are free of metals and halogens,

in some cases fully biodegradable, have less complex and environmentally damaging syntheses, and are less expensive (Heldebrant et al., 2006). One should be asked if LPs could be labeled “green”. For example, PEG is a “green solvent” as it is nonvolatile, nonflammable, nontoxic to humans, animals, and aquatic life, and biodegradable by bacteria in soil and sewage. However, other LPs have at least one less desirable characteristic: PPG, PDMS and dialkylether-capped PEG are less biodegradable, PTHF in the form of an aqueous emulsion is toxic (Heldebrant et al., 2006).



**Figure 5.** Liquid polymers

The most commonly used LP is PEG. Low molecular weight PEG (below 600 Da), can be used as a solvent in its pure form, while PEGs above 800 Da, are a low melting point waxy solid that requires elevated temperatures or co-solvents (commonly water) to be used as reaction media. PEG is highly soluble in water and effectively lowers the polarity of aqueous solutions facilitating the dissolution of a greater range of organic substrates, increasing the range of reactions than can be carried out in aqueous solutions. Moreover, it is also soluble in many organic solvents but insoluble in non-polar organic solvents, e.g. hexane and supercritical carbon dioxide (Clarke et al., 2018). As PEG increases the range of substrates available for aqueous phase reactions and it is reported to be stable to acid and basic conditions it has been used as a substitute for conventional solvents in organic synthesis. Aqueous solutions of PEG form two immiscible phases that separate when the concentration of PEG or a solute is adjusted. For example, aqueous biphasic systems formed by mixing PEG with water and salt (usually phosphate, citrate, or sulfate) have been used extensively for the separation and purification of proteins and biomolecules. In organic synthesis, PEG is used as an effective solvent for many cross-coupling and polymerisation reactions, for the synthesis of functional organic materials, nanorods, and nanoparticles, it is used as an effective chelator of metals and salts, and used for catalyst recovery. The commercial use of PEG and PPG, as a replacement for conventional solvents, is not fully exploited. Moreover, the regulatory and technological restrictions for the introduction of these two LPs as industrial solvents are likely to be low (Clarke et al., 2018).

## SUPERCritical CARBON DIOXIDE

Supercritical carbon dioxide ( $\text{scCO}_2$ ) is carbon dioxide in a fluid state at temperatures and pressures above its critical point (304.13 K, 7.3773 MPa). The fact that  $\text{CO}_2$  is non-toxic and non-flammable, makes  $\text{scCO}_2$  a

green solvent. Moreover, it is cheap and readily available. As the polarity of pure  $\text{scCO}_2$  is very low, organic co-solvents are usually added to increase the solubility of polar reagents and products. Considering this,  $\text{scCO}_2$  seems to be a good alternative to traditional organic solvents for academic and commercial applications. Due to its good miscibility with gases, it is a good solvent for hydrogenation and hydroformylations, as well as for oxidations with molecular oxygen.  $\text{CO}_2$  is a good medium for oxidation reactions not only because of the good solubility of molecular oxygen in  $\text{CO}_2$  but also because  $\text{CO}_2$  can not be further oxidated or combusted. Moreover, it is used for transition-metal catalyzed cross couplings. It has been used extensively as an extraction solvent in the food, beverage, flavor, and cosmetic industries. A wide range of compounds, including lipids, oils, terpenes, phytochemicals, glycosides, and vitamins, can be extracted by  $\text{scCO}_2$ . Moreover, it is used for the synthesis and processing of bulk materials, aerogels, thin films, coatings, particle suspensions, powders, and nanoparticles, as well as for the synthesis and processing of polymers (Clarke et al., 2018).

The main disadvantage of  $\text{scCO}_2$  as a solvent is that its application requires high capital installation, running costs, and operating pressures. High pressures result in potential operational safety risks, as well as relatively high energy demands, which pose a challenge to the feasibility of commercial operation of  $\text{scCO}_2$ -based processes (Beckman, 2004; Clarke et al., 2018).

## GAS-EXPANDED LIQUIDS

Another usage of  $\text{CO}_2$  can be the formation of gas-expanded liquids (GXLs) that are formed when  $\text{CO}_2$  is dissolved into an organic liquid, which induces the liquid to expand volumetrically (Jessop and Subramaniam, 2017). The properties of GXLs are between the ones of supercritical fluids and organic solvents and they depend on and can be controlled by altering the temperature, pressure, or amount of gas in the system. GXLs are applied in chemical synthesis, most utilizing gaseous reagents and metal catalysts, e.g. hydrogenations, oxidations, and hydroformylations. Moreover, GXLs can be used for biomass extractions due to high extraction rates, and low operating temperatures, which allow the extraction of sensitive compounds without thermal decomposition. Compared to traditional liquid phase processes, expanded liquids offer higher diffusivity, lower viscosity, and increased safety due to the non-flammable medium (inserted by  $\text{CO}_2$ ).

## SWITCHABLE SOLVENTS

Finally, the last class of sustainable solvents that will be mentioned herein is switchable solvents (SSs). Their main property is that they are changed when they are exposed to various triggers such as gasses, heat, or light. The triggers should be safe for use, cheap, to



produce little to no waste with a readily reversible mechanism, and the advantages of their use are low-energy methods for separations and post-reaction work-up procedures, as well as an easier way of recycling the solvent medium and improvement of product and catalyst recovery. There are three subclasses of switchable solvents: switchable polarity solvents (SPSs), switchable hydrophobicity solvents (SHSs) and switchable water (SW). SS-based techniques have been applied to different matrices (environmental, biological, and agricultural) to determine a wide range of analytes (including metals, organic contaminants, or metabolites) in combination with chromatographic or spectroscopic instrumental techniques (Lopez-Ruiz et al., 2021).

## CONCLUSION

Solvents comprise ca. 80–90% of the total mass of an organic reaction, and although there are serious efforts to eliminate or reduce the use of solvent, their use is often inevitable due to solubility, selectivity, and safety issues, as well as handling. Even in solvent-free reactions, solvents are used for purification, extraction and separation of products. Moreover, their use is unavoidable in many industrial chemical processes.

As one of the 17 sustainable development goals of the agenda “Transforming Our World: The 2030 Agenda for Sustainable Development” outlined in 2015 by the UN is the need for green and sustainable chemistry and engineering, transfer from classical to sustainable solvents is one of the directions towards that goal. In the last few decades, serious efforts have been made to introduce green solvents in laboratory practice, as well as in industry. Nevertheless, some properties that make green solvents beneficial for laboratory application from a technical, economic, or ecological point of view may be disadvantageous for their industrial application.

Unfortunately, there is no universal green solvent and users' choice of the optimal green solvent is based on prior chemistry, costs, environmental impact, etc. The major challenges in green solvent research are to ensure that they may replace nongreen ones, to assess their environmental impact and to evaluate whether their use is cost-effective and economically justified.

## REFERENCES

Anastas, P.T., Warner, J.C. (1998). *Green Chemistry: Theory and Practice*, Oxford: Oxford University Press.

Beckman, E.J. (2004). ‘Supercritical and Near-Critical CO<sub>2</sub> in Green Chemical Synthesis and Processing’, *The Journal of Supercritical Fluids*, 28(2–3), pp. 121–191.

Centers for Disease Control and Prevention, CDC (2022). *Organic Solvents*, [online], available: <https://www.cdc.gov/niosh/topics/organsolv/default.html> [Accessed 25 July 2022].

Clark, J.H., Farmer, T.J., Hunt, A.J., Sherwood, J. (2015). ‘Opportunities for Bio-Based Solvents Created as Petrochemical and Fuel Products Transition Towards

Renewable Resources’, *International Journal of Molecular Sciences*, 16(8), pp. 17101–17159.

Clarke, C.J., Tu, W.-C., Levers, O., Bröhl, A., Hallett, J.P. (2018) ‘Green and Sustainable Solvents in Chemical Processes’, *Chemical Reviews*, 118(2), pp. 747–800.

ESIG, European Solvents Industry Group (2022). *Solvents and ESIG*, [online], available: [https://www.esig.org/wp-content/uploads/2020/01/ESIG-advocacy-document-triptic\\_WEB.pdf](https://www.esig.org/wp-content/uploads/2020/01/ESIG-advocacy-document-triptic_WEB.pdf) [Accessed 25 July 2022].

Greer, A.J., Jacquemin, J., Hardacre, C. (2020). ‘Industrial Applications of Ionic Liquids’, *Molecules*, 25(21), 5207.

Hansen, B.B., Spittle, S., Chen, B., Poe, D., Zhang, Y., Klein, J.M., Horton, A., Adhikari, L., Zelovich, T., Doherty, B.W., Gurkan, B., Maginn, E.J., Ragauskas, A., Dadmun, M., Zawodzinski, T.A., Baker, G.A., Tuckerman, M.E., Savinell, R.F., Sangoro, J.R. (2021). ‘Deep Eutectic Solvents: A Review of Fundamentals and Applications’, *Chemical Reviews*, 121(3), pp. 1232–1285.

Heldebrant, D.J., Witt, H.N., Walsh, S.M., Ellis, T., Rauscher, J., Jessop, P.G. (2006). ‘Liquid polymers as solvents for catalytic reductions’, *Green Chemistry*, 8(9), pp. 807–815.

Jessop, P.G., Subramaniam, B. (2007). ‘Gas-Expanded Liquids’, *Chemical Reviews*, 107(6), pp. 2666–2694.

Lancaster, M. (2002). *Green Chemistry: An Introductory Text*, Cambridge: Royal Society of Chemistry, pp. 1–6.

Lei, Z., Chen, B., Koo, Y.-M., MacFarlane, D.R. (2017). ‘Introduction: Ionic Liquids’, *Chemical Reviews*, 117(10), pp. 6633–6635.

Lopez-Ruiz, I., Lasarte-Aragonés, G., Lucena, R., Cárdenas, S. (2021). ‘17 - Switchable solvents’, In: *Analytical Sample Preparation With Nano- and Other High-Performance Materials*, Lucena, R., Cárdenas, S. (Eds.), Amsterdam: Elsevier, pp. 453–470.

Merck (2022). Bioethanol – For a Sustainable Future, [online], available: <https://www.merckmillipore.com/INTL/en/reagents-chemicals-and-labware/bioethanol/86Kb.qB.LIkAAAFDdo9xDMUX.nav> [Accessed 25 July 2022].

Mohr, A., Raman, S. (2013). ‘Lessons from First Generation Biofuels and Implications for the Sustainability Appraisal of Second Generation Biofuels’, *Energy Policy*, 63, pp. 114–122.

Pace, V., Hoyos, P., Castoldi, L., Domínguez De María, P., Alcántara, A.R. (2012) ‘2-Methyltetrahydrofuran (2-MeTHF): A Biomass-Derived Solvent with Broad Application in Organic Chemistry’, *ChemSusChem*, 5(8), pp. 1369–1379.

Perna, F.M., Vitale, P., Capriati, V. (2020). ‘Deep Eutectic Solvents and Their Applications as Green Solvents’, *Current Opinion in Green and Sustainable Chemistry*, 21, pp. 27–33.

Prat, D., Wells, A., Hayler, J., Sneddon, H., McElroy, C.R., Abou-Shehata, S., Dunn, P.J. (2016). ‘CHEM21 Selection Guide of Classical- and Less Classical-Solvents’, *Green Chemistry*, 18, pp. 288–296.

Sansom, C. (2018). *Solvents and sustainability*, Chemistry world, [online], available: <https://www.chemistryworld.com/features/solvents-and-sustainability/3008751.article> [Accessed 25 July 2022].

Smith, E.L., Abbott, A.P., Ryder, K.S. (2014). ‘Deep Eutectic Solvents (DESS) and Their Applications’, *Chemical Reviews*, 114(21), pp. 11060–11082.

Strappaveccia, G., Ismalaj, E., Petrucci, C., Lanari, D., Marrocchi, A., Drees, M., Facchetti, A., Vaccaro, L. (2015). 'A Biomass-Derived Safe Medium to Replace Toxic Dipolar Solvents and Access Cleaner Heck Coupling Reactions', *Green Chemistry*, 17(1), pp. 365–372.

US EPA, United States Environmental Protection Agency (2022). *Basics of Green Chemistry*, [online], available: <https://www.epa.gov/greenchemistry/basics-green-chemistry> [Accessed 25 July 2022].

Wolfson, A., Dlugy, C., Shotland, Y. (2007). 'Glycerol as a Green Solvent for High Product Yields and Selectivities', *Environmental Chemistry Letters*, 5, pp. 67–71.

### ACKNOWLEDGEMENTS

The authors are grateful to the Ministry of Education, Science and Technological Development of the Republic of Serbia for the financial support of this work (contract number 451-03-68/2022-14/200148).

### BIOGRAPHY of the first author

**Ana Bijelić** was born in Niš, Serbia, in 1985. She received her diploma and a Ph.D. degree in chemistry from the University of Niš, Faculty of Sciences and Mathematics.

Her main areas of research include organic and environmental chemistry, occupational toxicology, instrumental methods of analysis, etc.

She is currently working as an Assistant Professor at the University of Niš, Faculty of Occupational Safety in Niš.







IRMA DERVIŠEVIĆ<sup>1</sup>  
ALMIN DERVIŠEVIĆ<sup>2</sup>  
MILICA TOMOVIĆ<sup>3</sup>  
JOVANA GALJAK<sup>4</sup>

<sup>1,3,4</sup> University of Prishtina with temporary headquarters in Kosovska Mitrovica, Faculty of Technical Sciences Kosovska Mitrovica, Serbia

<sup>2</sup> University of Novi Sad, Faculty of Technology Novi Sad, Serbia

<sup>1</sup>irma.dervisevic@pr.ac.rs

<sup>2</sup>almin007@hotmail.com

<sup>3</sup>milica.tomovic@pr.ac.rs

<sup>4</sup>jovana.galjak@pr.ac.rs

## INADEQUATE WASTE MANAGEMENT AS A CONSTANT THREAT TO THE ENVIRONMENT

**Abstract:** *Inadequate waste management is one of the biggest problems of environmental pollution not only in the Republic of Serbia, but also in all countries of the world where the proper waste management is not implemented. The paper analyzes the impact of the historical industrial landfill of the flotation tailings of lead-zinc ore of the Mining-Metallurgical-Chemical Combine "Trepca" on the environment of the local and wider area. The results of the analysis of heavy metals and other chemical elements in the Gornje Polje industrial landfill and their transfer into the surface soil, surface and groundwater of the northern part of Kosovska Mitrovica are presented. The following methods were used to determine the concentration of chemical elements: X-ray diffractometry (XRD), Atomic Absorption Spectroscopy (AAS) and Inductively Coupled Plasmas with Optical Emission Spectrometry (ICP-OES). Inadequate selection of locations for storage and disposal of industrial waste in the immediate vicinity of the rivers Sitnica and Ibar, with inadequate and inefficient management, has further contributed to pollution and constant threats to the environment of the narrower and wider area, especially pointing to risks and dangers in case of some natural disasters.*

**Key words:** historically accumulated waste, environmental degradation, natural disasters, multiplication of pollution

## INTRODUCTION

The economic development of Kosovo and Metohija in the twentieth century is connected with the industrial complex of the Mining-Metallurgical-Chemical Plant - (RMHK) "Trepca", one of the largest producers of lead, zinc, silver and gold in Europe, which worked continuously for seventy years (1929 - 1999). As a result of the exploitation, flotation, processing and production of lead-zinc ore by mining-metallurgical and chemical-technological processes, there was great damage and pollution to the environment of this area (Milentijevic, 2013). Various waste materials, intermediates, slag, dust and sludge, which contain heavy metals, toxic compounds and other polluting components, have been deposited in the immediate vicinity of these plants (Milentijevic, 2016). Precisely, the greatest threat to the environment and human health is currently "historical waste" not only because of the amount and chemical composition of these waste substances but also because of inadequate treatment, and inadequate selection of sites for their dislocation and disposal, because there is a real danger of multiplying the possible risks of endangering the narrower and wider area (Martinez, 2016), especially in the case of some natural disasters. During the intensive work from Production Plant Trepca, during the eighties

of the last century, only the main chimneys released into the atmosphere: 1,215 t / year Pb, 60 t / year Zn, 2 t / year Cd and 6 t / year Hg, etc. It is estimated that the release of pollutants into the water was: 150 t / year Pb, 300-900 t / year Zn, 900 t / year fluoride, etc. (Trepca Conf Report, 2011).

## ASSESSMENT OF THE STATE OF THE ENVIRONMENT IN THE NORTH OF KOSOVO AND METOHIIJA

The greatest threat to the environment and human health are the landfills of "historical industrial waste" in Table 1, shows some landfills of industrial waste, which was generated and dumped near the former mines in north and central Kosovo and Metohija (Trepca Conf Report, 2011).

The area of Kosovska Mitrovica is considered one of the most contaminated areas in the Western Balkans (Sajn, 2013). Table 2 shows the most significant industrial pollutants in the area of Kosovska Mitrovica.

The flotation landfill Gornje Polje is located on the very bank of the river Ibar, in the area between Kosovska Mitrovica and Zvečan. Flotation tailings of lead-zinc ore were deposited at this landfill from the beginning of the mine flotation operation in 1930 until

its closure in 1983. This landfill contains about 12 million cubic meters of tailings, covering an area of about 500,000 m<sup>2</sup> (Borgna, 2008).

**Table 1.** The most important and largest landfills of historical industrial waste (from former mines) "RMHK Trepca" - Rudarako Metalurško Hemijski Kombinat Trepča (Mining Metallurgical Chemical Combine Trepca)

Name	Location	Status	Area size (ha)	Amount of waste (t)
Gornji Kmjn	Leposavic	abandoned	6.5	2 600 000
Bostanište	Leposavic	active	8 - 10	3 600 000
Žitkovac	Zvecan	abandoned	26	8 500 000
Gornje Polje	Zvecan	abandoned	50	12 000 000
Gornje Polje	Zvecan lead dump	abandoned	4 - 6	2 500 000
Zvecan	Zvecan dust dump	abandoned	10 - 15	10 000 000
Keljimendi	Keljimendi tailings dam	active	8 - 10	3 600 000
Industrial park	Kosovska Mitrovica	abandoned	35	4 200 000
Old tailings	Gracanica	abandoned	40	11 000 000
Badovci	Badovci	active	18-20	7 700 000
Novo Brdo	Novo Brdo	abandoned	4	1 800 000
In total			209-220	67 500 000

**Table 2.** Significant pollutants in the area of Kosovska Mitrovica

Name of the Pollutant	Characteristics of the pollutant	Note	Pollution Spill Site
1. Chemical industry "Fafos"	complex chemical pollution	constant pollution	river Sitnica
2. Metallurgy of Zn	heavy metal pollution	plant out of production	river Sitnica
3. Production of Battery	heavy metal pollution	plant out of production	river Sitnica
4. "Stari trg" Mine	heavy metal pollution	constant pollution	Barska Reka
5. Flotation landfill "Žarkov potok"	complex chemical pollution	constant pollution	river Ibar
6. Landfill "Gornje polje"	complex chemical pollution	constant pollution	river Ibar
7. Metallurgy of Lead	heavy metal pollution	plant out of production	river Ibar
8. Landfill "Žitkovac"	complex chemical pollution	constant pollution	river Ibar

Due to the position of the Gornje Polje landfill, the low level of stability of the landfill slopes, there is a constant risk of occasional erosion of material (Paktunc, 1991, Frese, 20004) into the Ibar River, as well as the risk of possible large erosion of this material in case of floods, which is a constant risk of environmental disaster. On the other hand, the estimated total amount of deposited material, diverse metal content, is a source of valuable components that could be valorized. The paper examines the chemical composition of the constituents of this landfill, as well as the quantities of valuable and toxic metals that, thus disposed of, pose a danger to the environment. Surface and groundwater samples in the immediate vicinity of the landfill and the wider area were also analyzed to determine their impact on the environment.

## MATERIAL AND METHODS

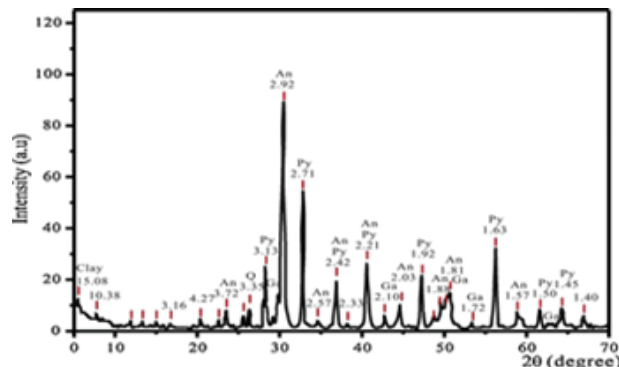
The paper examines the content of metals and other chemical constituents in the flotation landfill Gornje Polje, as well as the physicochemical characteristics of the river Ibar which is in direct contact with waste materials at the landfill Gornje Polje and the quality of groundwater, well water in the immediate vicinity.

Samples of flotation landfill and sediment were placed in plastic bags (Density low density polyethylene - LDPE), and samples of surface and groundwater in plastic bottles (Polyethylene terephthalate - PET). After measuring the temperature of the samples, until the moment of testing, the samples were stored in a manual refrigeration device at a temperature of 4 ° C.

The following methods were used to determine the concentration of chemical elements: X-ray diffractometry (XRD), Atomic Absorption Spectroscopy (AAS) and Inductively Coupled Plasma with Optical Emission Spectrometry (ICP-OES).

## RESULTS AND DISCUSSION

Chemical analysis of mineral content in flotation tailings at the Gornje Polje landfill tested by XRD method is shown in Figure 1 and Table 3. Samples of deposited material were taken from depths of 0.5 and 1 m.



**Figure 1.** Diagram of chemical analysis of mineral content in flotation tailings at the Gornje Polje landfill by XRD method (Py-pyrite, An-ankerite, Ga-galena).

The deposited flotation tailings are mostly oxidized and solid (Mihone, Nannoni, 2010). The primary ore minerals are galena, sphalerite, pyrite, arsenopyrite and pyrrhotine. The major gangue minerals are carbonates with variable cation composition (calcite, kuthnohorite, rodochrosite, siderite) and quartz. Usually, skarn minerals (ilvaite, hedenbergite, garnet) precede sulfide mineralization.

**Table 3.** XRF chemical analysis of the tailing waste deposit Gornje Polje

Element	Pb	As	Zn	Cu	Ni	Fe
mg/kg	2736	3867	1848	177.3	115.78	117786
Element	Mn	Cr	Rb	Sr	Zr	
mg/kg	8241.41	366.8	72.1	120.5	109.1	

To investigate the distribution of heavy metals by grain shape and size, samples were examined by scanning electron microscopy, and chemical analysis was performed using AAS on samples 1–6, and the results are shown in Table 4.

**Table 4.** Chemical composition of tailings waste "Gornje Polje".

Sample	Pb wt%	Zn wt%	Cu wt%	Fe wt%	S wt%	Mn wt%	As wt%
1	0.28	0.27	0.033	27.96	17.11	5.25	0.76
2	0.29	0.24	0.045	29.88	17.22	5.77	0.65
3	0.71	0.24	0.045	23.93	12.14	6.70	1.01
4	0.43	0.26	0.030	22.90	10.18	7.57	1.01
5	0.82	0.28	0.021	20.83	8.79	7.60	1.23
6	0.28	0.27	0.020	20.48	9.95	7.49	1.17
Mean	0.46	0.26	0.03	24.33	12.56	6.73	0.97
St. Dev.	0.23	0.01	0.01	3.82	3.72	1.01	0.22
Max.	0.82	0.28	0.04	29.88	17.22	7.60	1.23
Min.	0.28	0.24	0.02	20.48	8.79	5.25	0.65

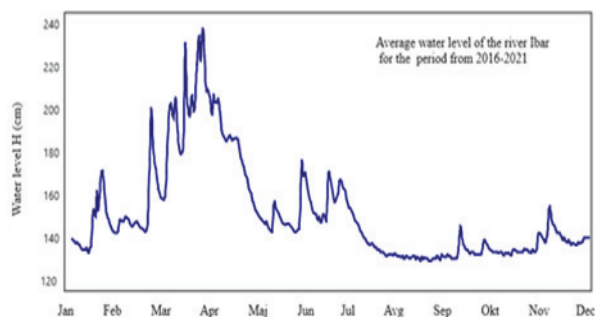
Sample	Fe <sub>2</sub> wt%	FeS wt%	Cd wt%	Ag mg/kg	Zr mg/kg	Sr mg/kg	Rb mg/kg
1	18.33	18.46	0.00	7	121.7	160.6	79
2	15.90	22.17	0.00	11	101	170.0	22
3	15.64	9.35	0.006	8	0.00	124.7	81
4	14.05	6.57	0.00	11	48	87.6	6
5	13.21	3.95	0.005	8	39	110.6	33
6	14.67	4.98	0.00	11	0.00	110.0	67
Mean	15.30	10.91	0.001	9.33	51.61	127.25	48
St. Dev.	1.78	7.59	0.002	1.86	50.69	31.91	31.86
Max.	18.33	22.17	0.006	11	121.7	170	81
Min.	13.21	3.95	0.00	7	0.00	87.6	6



**Figure 3.** Different waste materials reached surface waters in their immediate vicinity

Large floating material that reaches recipients from different locations is visible, while waste material from industrial landfills that reaches nearby recipients is not so visible, but it is far more dangerous with multiple consequences. The deposited material at the "Gornje Polje" landfill almost constantly erodes into the immediate environment, as illustrated in Figure 4.

Since the flotation tailings dump is located on the very bank of the Ibar River, the pollutants reach the river and the immediate surroundings, especially in conditions of high water level, ie during higher atmospheric precipitation. Figure 2 shows the average water level of the river Ibar for the period 2016-2021.



**Figure 2.** Average water level of the river Ibar for the period from 2016-2021.

During higher atmospheric precipitation, different waste materials deposited in their immediate surroundings reach the nearby recipients, which is illustrated by the photographs in Figure 3.



**Figure 4.** Mining stream that passes through the landfill "Gornje polje" and flows into the river Ibar

Constant and complex pollution of the area due to the presence of a large number of industrial landfills and illegal municipal solid waste landfills located in close vicinity or on the banks of the local rivers and the determined presence of heavy metals from industrial plants and landfills, and other hazardous and noxious substances, which are very high on the list of pollutants in this area due to their toxicities, has initiated the examination of the content of heavy metals in the river Ibar and groundwater's down-stream from Grabovac and the landfill site Balaban (Pb, Cr, Ni, Cd, Zn and Hg). The test results are given in Table 5. A sampling of surface and groundwater was determined at three sites in three different periods. The results of the

analysis of surface and groundwater samples are shown in Table 5.

Based on the results presented in Table 5 and exceeding limits of certain physical and chemical parameters (concentration of dissolved O<sub>2</sub>, COD, BOD<sub>5</sub>, sulphates, nitrites and phenols) and considering determined extremely high concentrations of lead and copper in three of the samples of surface water and cadmium in the two, the surface waters of the investigated locations are classified in the III, IV or V class, which designates the poor quality of the water,

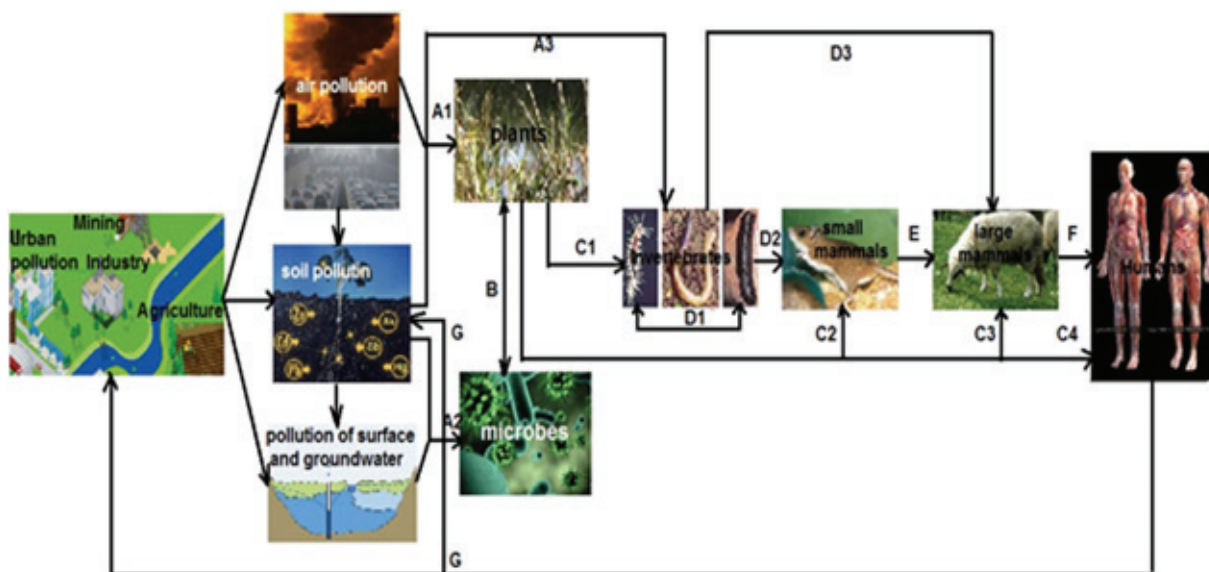
unusable for irrigation of agricultural crops. According to reference (Ocokoljic, 2009) water quality of the river Ibar is decreasing. What is particularly worrying is that increased contents of mercury and phenols were found in well water at the location in Grabovac, which is used for drinking.

The existence of such complex pollution requires immediate action, especially given that polluted water can cause serious consequences for human health, plants and animals, and the whole environment. The waste, disposed of in this and other locations

**Table 5.** Physicochemical parameters and concentration of heavy metals in the surface water at the sites of Grabovac and Balaban and in well water at the sites of Grabovac

The investigated parameters	unit	The quality of water by classes													
		based on parameter values													
		Grabovac Apr./20	Grabovac Sep./20	Grabovac Feb./21	Balaban Apr/20	Balaban Sep./20	Balaban Feb./21	Grabovac Apr./20	Grabovac Sep./20	Grabovac Feb./21	I	II	III	IV	V
Scent		the smell of rot	the smell of rot	the smell of rot	the smell of rot	the smell of rot	the smell of rot	without	without						
Colors	NTU	2.1	2.0	2.2	2.1	1.9	2.1	no color	no color	no color					
Suspended solids	mg/dm <sup>3</sup>	21	18	19	9.5	14	11	4	4	4 without	25	25	-	-	-
The water temperature in the filed	°C	12	16	9	8	15	6	9	10	9					
The air temperature	°C	10	15	7	7	14	3	10	15	8					
Electrical conductivity	mg/dm <sup>3</sup>	442	508	451	442	395	369	236	224	230	<1000	1000	1500	3000	>3000
The pH value	mg/dm <sup>3</sup>	7.9	8.1	8.2	7.8	8.1	7.9	7.8	7.9	7.9	6.5-8.5	6.5-8.5	6.5-8.5	6.5-8.5	<6.5 or >8.5
The concentration of dissolved O <sub>2</sub>	mg/dm <sup>3</sup>	5.4	5.3	5.4	6.1	6.3	6.2	8.9	8.7	8.8	-	7	5	4	<4
Biological oxygen demand BOD <sub>5</sub>	mg/dm <sup>3</sup>	7.2	6.9	7.1	5.8	5.8	5.7	3.9	4.2	4.5	-	5	7	25	>25
Chemical oxygen demand	mg/dm <sup>3</sup>	17.3	16.5	17.2	12.8	13.7	12.6	5.9	5.5	5.7	5	10	20	50	>50
Hardness of water	°dH	198	189	170	201	203	199	175	178	175					
Nitrates	mg/dm <sup>3</sup>	1.2	0.8	0.65	0.39	0.47	0.34	0.02	0.02	0.02	0.01	0.03	0.12	0.3	>0.3
Phosphates	mg/dm <sup>3</sup>	0.1	0.07	0.06	0.1	0.08	0.05	0.03	0.03	0.02	-	0.1	0.2	0.5	>0.5
Sulfates	mg/dm <sup>3</sup>	95.50	94.66	88.45	81.74	76.63	75.41	43.72	56.80	59.67	50	100	200	300	>300
Chloride	mg/dm <sup>3</sup>	18.4	18.3	18.1	18.3	18.7	18.1	10.3	10.5	10.1	50	100	150	250	>250
Chrome	µg/dm <sup>3</sup>	0.09	2.58	2.76	0.28	0.27	2.61	0.05	<0.05	0.05	25	50	100	250	>250
Nickel	µg/dm <sup>3</sup>	1.8	6.59	3.12	0.10	0.09	3.28	0.18	0.16	0.17	20	25	50	100	>100
Lead	µg/dm <sup>3</sup>	193.22	148.31	132.15	54.68	39.90	27.62	12.97	18.85	13.81	50	100	100	200	>200
Cadmium	µg/dm <sup>3</sup>	5.0	17.68	0.10	0.06	0.06	13.12	0.06	0.05	0.05	5 and <	30 and <	100 <	200	>200
Zink	µg/dm <sup>3</sup>	3.24	7.24	3.21	0.06	<0.05	0.81	0.08	0.09	0.10	10	100	200	500	1000
Mercury	µg/dm <sup>3</sup>	0.01	0.35	0.43	0.03	0.02	0.37	5.98	4.99	5.48	5	5	<10	10	>10
Iron	µg/dm <sup>3</sup>	94	75	80	74	75	56	47	40	38	100	200	500	1000	2000
Copper	µg/dm <sup>3</sup>	112	124	310	85	57	65	18	22	19	10	100	200	500	1000
Calcium	mg/dm <sup>3</sup>	64.7	67.6	65.8	85.6	70.7	69.2	60.5	57.3	67.4	-	-	-	-	-
Magnesium	mg/dm <sup>3</sup>	17.4	19.2	18.7	26.5	21.4	20.8	14.1	18.4	11.9	-	-	-	-	-
Phenols	mg/dm <sup>3</sup>	0.008	0.006	0.004	0.006	0.005	0.004	0.002	0.001	0.002	0.001	0.001	/	/	/





**Figure 5.** Pathways of metal transfer in the terrestrial food web and selected references for each pathway (A1–G) (Gall, 2015): (A1) (Van de Ent, 2013, Pollard, 2014); (A2) (Giller, 2009, Gadd, 2010, Boshoff, 2014); (A3) (Heikens, 2001, Hobbelen, 2006); (B) (Wenzel, 2009, Hol, 2010, Kothe, 2014); (C1) (Janssens, 2009, Migula, 2011, Nica, 2012, Meindl, 2014, Bouriou, 2015); (C2) (Lopes, 2002, Beernaert, 2007, Sanchez Chardi, 2007); (C3) (Reglero, 2008, Philips, 2011, Roggeman, 2013); (C4) (Cao, 2010, Sahoo, 2013, Street, 2012, Peterson, 2003, Green, 2010, Cheruyot, 2013); (D2) (Sanchez Chardi, 2007, Moriarty, 2012, Drouhot, 2014); (D3) (Reglero, 2009); (F) (Chary, 2008); (G) (Luo, 2009, Atafar, 2010, McClellan, 2010, Jiao, 2012).

is washed by atmospheric precipitation that leaches toxic and harmful substances into the immediate environment: soil, surface water and groundwater, and crops, so that these contaminants enter the food chain. Pathways of metal transfer in the soil and food chain, along with the selected references for each pathway (Gall, 2015) are shown in Figure 5.

This research certainly contributes to understanding the impact that industrial waste has on the environment and human health and requires urgent intervention with the aim of possible utilization of secondary raw materials, rehabilitation/reclamation of this and other similar landfills.

## CONCLUSIONS

Considering the age of the Gornje Polje tailing waste deposit, the broad instrumental analyses have shown that the recyclable metals, lead and zinc are in the forms of sulphides, but also in the form of soluble carbonates, and sulfates, as a consequence of tailing waste deposit aging and oxidation. For a final decision on the recycling possibilities to be proposed, a detailed analysis of the depth column is needed. Even though the occurrence was confirmed, the techniques used in this study were not precise enough for rare metals analysis. A proper feasibility study will show if any of the tailing waste recycling is viable, but for the time being, remediation of the tailing waste deposit in order to prevent pollution and reduce hazard by increasing the stability of the slopes, seems to be an adequate solution.

## REFERENCES

- Atafar, Z., Mesdaghinia, A., Nouri, J., Homae, M., Yunesian, M., Ahmadimoghaddam, M. and Mahvi, A.H. (2010). 'Effect of Fertilizer Application on Soil Heavy Metal Concentration'. *Environmental Monitoring and Assessment*, 160, 83-89. <http://dx.doi.org/10.1007/s10661-008-0659-x>
- Beernaert, J., Scheirs, J., Leirs, H., Blust, R. and Verhagen, R. (2007). 'Non-Destructive Pollution Exposure Assessment by Means of Wood Mice Hair'. *Environmental Pollution*, 145, 443-451. <http://dx.doi.org/10.1016/j.envpol.2006.04.025>
- Borgna, L., Di Lella, L.A., Nannoni, F., Pisani, A., Pizzetti, E., Protano, G., Riccobono, F., Rossi, S., (2009). 'The high contents of lead in soils of Northern Kosovo', *J. Geochem. Explor.* 101 137-146, <https://doi.org/10.1016/j.gexplo.2008.05.001>.
- Boshoff, M., De Jonge, M., Dardenne, F., Blust, R. and Bervoets, L. (2014). 'The Impact of Metal Pollution on Soil Faunal and Microbial Activity in Two Grassland Ecosystems'. *Environmental Research*, 134, 169-180. <http://dx.doi.org/10.1016/j.envres.2014.06.024>
- Bouriou, M., Gimbert, F., Alaoui-Sehmer, L., Benbrahim, M., Aleya, L. and Alaoui-Sossé, B. (2015). 'Sewage Sludge Application in a Plantation: Effects on Trace Metal Transfer in Soil-Plant-Snail Continuum'. *Science of the Total Environment*, 502, 309-314. <http://dx.doi.org/10.1016/j.scitotenv.2014.09.022>
- Cao, H., Chen, J., Zhang, J., Zhang, H., Qiao, L. and Men, Y. (2010). 'Heavy Metals in Rice and Garden Vegetables and Their Potential Health Risks to Inhabitants in the Vicinity of an Industrial Zone in Jiangsu, China'. *Journal of Environmental Sciences*, 22, 1792-1799. [http://dx.doi.org/10.1016/S1001-0742\(09\)60321-1](http://dx.doi.org/10.1016/S1001-0742(09)60321-1)

- Chary, N.S., Kamala, C.T. and Raj, D.S.S. (2008). 'Assessing Risk of Heavy Metals from Consuming Food Grown on Sewage Irrigated Soils and Food Chain Transfer'. *Ecotoxicology and Environmental Safety*, 69, 513-524. <http://dx.doi.org/10.1016/j.ecoenv.2007.04.013>
- Cheruiyot, D.J., Boyd, R.S., Coudron, T.A. and Cobine, P. (2013). 'Biotransfer, Bioaccumulation and Effects of Herbivore Dietary Co, Cu, Ni and Zn on Growth and Development of the Insect Predator *Podisus maculiventris* (Say) (Hemiptera: Pentatomidae)'. *Journal of Chemical Ecology*, 39, 764-772. <http://dx.doi.org/10.1007/s10886-013-0289-9>
- Drouhot, S., Raoul, F., Crini, N., Tougaard, C., Prudent, A.S., Druart, C., Rieffel, D., Lambert, J.C., Tête, N., Giraudoux, P. and Scheifler, R. (2014). 'Responses of Wild Small Mammals to Arsenic Pollution at a Partially Remediated Mining Site in Southern France'. *Science of the Total Environment*, 470-471, 1012-1022. <http://dx.doi.org/10.1016/j.scitotenv.2013.10.053>
- Frese, S., Klitgaard, R., Kock Pedersen, E., (2004). 'Heavy Metal emission from Trepca', *Environmental Management in Kosovo TekSam, Institut for Miljo, Teknologj og Samfund*.
- Gadd, G.M. (2010). 'Metals, Minerals and Microbes', *Geomicrobiology and Bioremediation. Microbiology*, 156, 609-643. <http://dx.doi.org/10.1099/mic.0.037143-0>
- Gall, J.E., Boyd, R.S. and Rajakaruna, N. (2015). 'Transfer of Heavy Metals through Terrestrial Food Webs: A Review'. *Environmental Monitoring and Assessment*, 187, 187-201. <http://dx.doi.org/10.1007/s10661-015-4436-3>
- Giller, K.E., Witter, E. and McGrath, S.P. (2009). 'Heavy Metals and Soil Microbes'. *Soil Biology and Biochemistry*, 41, 2031-2037. <http://dx.doi.org/10.1016/j.soilbio.2009.04.026>
- Green, I.D., Diaz, A. and Tibbett, M. (2010). 'Factors Affecting the Concentration in Seven-Spotted Ladybirds (*Coccinella septempunctata* L.) of Cd and Zn Transferred through the Food Chain'. *Environmental Pollution*, 158, 135-141. <http://dx.doi.org/10.1016/j.sajb.2012.07.013>
- Heikens, A., Peijnenburg, W.J.G.M. and Hendriks, A.J. (2001). 'Bioaccumulation of Heavy Metals in Terrestrial Invertebrates'. *Environmental Pollution*, 113, 385-393. [http://dx.doi.org/10.1016/S0269-7491\(00\)00179-2](http://dx.doi.org/10.1016/S0269-7491(00)00179-2)
- Hobbelen, P.H.F., Koolhaas, J.E. and Van Gestel, C.A.M. (2006). 'Bioaccumulation of Heavy Metals in the Earthworms *Lumbricus rubellus* and *Aporrectodea caliginosa* in Relation to Total and Available Metal Concentrations in Field Soils'. *Environmental Pollution*, 144, 639-646. <http://dx.doi.org/10.1016/j.envpol.2006.01.019>
- Hol, W.H., de Boer, W., Termorshuizen, A.J., Meyer, K.M., Schneider, J.H.M., van Dam, N.M., van Veen, J.A. and van der Putten, W.H. (2010). 'Reduction of Rare Soil Microbes Modifies Plant-Herbivore Interactions'. *Ecology Letters*, 13, 292-301. <http://dx.doi.org/10.1111/j.1461-0248.2009.01424.x>
- Janssens, T.K.S., Roelofs, D. and van Straalen, N.M. (2009). 'Molecular Mechanisms of Heavy Metal Tolerance and Evolution in Invertebrates'. *Insect Science*, 16, 3-18. <http://dx.doi.org/10.1111/j.1744-7917.2009.00249.x>
- Jiao, W., Chen, W., Chang, A.C. and Page, A.L. (2012). 'Environmental Risks of Trace Elements Associated with Long-Term Phosphate Fertilizers Applications: A Review'. *Environmental Pollution*, 168, 44-53. <http://dx.doi.org/10.1016/j.envpol.2012.03.052>
- Kothe, E. and Büchel, G. (2014). 'Umbrella: Using Microbes for the Regulation of Heavy Metal Mobility at Ecosystem and Landscape Scale'. *Environmental Science and Pollution Research*, 21, 6761-6764. <http://dx.doi.org/10.1007/s11356-014-2689-y>
- Lopes, P.A., Viegas-Crespo, A.M., Nunes, A.C., Pinheiro, T., Marques, C., Santos, M.C. and Mathias, M.L. (2002). 'Influence of Age, Sex, and Sexual Activity on Trace Element Levels and Antioxidant Enzyme Activities in Field Mice (*Apodemus sylvaticus* and *Mus pretus*)'. *Biological Trace Element Research*, 85, 227-239. <http://dx.doi.org/10.1385/BTER:85:3:227>
- Luo, L., Ma, Y., Zhang, S., Wei, D. and Zhu, Y.G. (2009). 'An Inventory of Trace Element Inputs to Agricultural Soils in China'. *Journal of Environmental Management*, 90, 2524-2530. <http://dx.doi.org/10.1016/j.jenvman.2009.01.011>
- Martínez-Martínez, S., Acosta, J.A., Faz Cano, Carmona, A. D.M., Zornoza, R., Cerda, C., (2012). 'Assessment of the lead and zinc contents in natural soils and tailing ponds from the Cartagena-La Unión mining district', *SE Spain, J. Geochem. Explor.* 124 166-175, <https://doi.org/10.1016/j.gexplo.2012.09.004>.
- McClellan, K. and Halden, R.U. (2010). 'Pharmaceuticals and Personal Care Products in Archived US Biosolids from the 2001 EPA National Sewage Sludge Survey'. *Water Research*, 44, 658-668. <http://dx.doi.org/10.1016/j.watres.2009.12.032>
- Meindl, G.A., Bain, D.J. and Ashman, T.-L. (2014). 'Variation in Nickel Accumulation in Leaves, Reproductive Organs and Floral Rewards in Two Hyperaccumulating Brassicaceae Species'. *Plant and Soil*, 383, 349-356. <http://dx.doi.org/10.1007/s11104-014-2184-8>
- Migula, P., Przybyłowicz, W.J., Nakonieczny, M., Augustyniak, M., Tarnawska, M. and Mesjasz-Przybyłowicz, J. (2011). 'Micro-PIXE Studies of Ni-Elimination Strategies in Representatives of Two Families of Beetles Feeding on Ni-Hyperaccumulating Plant *Berkheya coddii*'. *X-Ray Spectrometry*, 40, 194-197. <http://dx.doi.org/10.1002/xrs.1310>
- Mihone Kerolli, M., Mandić V., Curković, L., Sipusić J., 'Investigation of thermal decomposition of jarosite tailing waste', *Journal of Thermal Analysis and Calorimetry* <http://dx.doi.org/10.1007/s10973-015-4881-9>.
- Milentijević, G., Nedeljković, B., Lekić, M., Nikić, Z., Ristović, I., Djokić, J. (2016). 'Application of a method for intelligent multi-criteria analysis of the environmental impact of tailing ponds in Northern Kosovo and Metohija', *Energies* 9 (11) 935-952, <https://doi.org/10.3390/en9110935>.
- Milentijević, G., Spalević, Ž., Bjelajac, Ž., Djokić, J., Nedeljković, B. (2013). 'Impact Analysis of Mining Company' Trepca' to the Contamination of the River Ibar Water', *National Vs. European Law Regulations, Metalurgia International* 18 283-288.
- Moriarty, M.M., Koch, I. and Reimer, K.J. (2012). 'Arsenic Speciation, Distribution and Bioaccessibility in Shrews and Their Food'. *Archives of Environmental Contamination and Toxicology*, 62, 529-538. <http://dx.doi.org/10.1007/s00244-011-9715-6>
- Nannoni, F., Protano, G., Riccobono, F., (2011). 'Fractionation and geochemical mobility of heavy elements in soils of a mining area in Northern Kosovo', *Geoderma* 161 63-73, <https://doi.org/10.1016/j.geoderma.2010.12.008>.
- Nica, D.V., Bura, M., Gergen, I., Harmanescu, M. and Bordean, D. (2012). 'Bioaccumulative and Conchological Assessment of Heavy Metal Transfer in a Soil-Plant-Snail

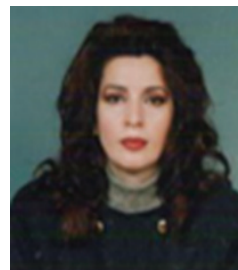
- Food Chain'. *Chemistry Central Journal*, 6, 55. <http://dx.doi.org/10.1186/1752-153X-6-55>
- Ocokoljić, M., Milijašević, D. and Milanović, A. (2009). 'Rivers Classification of Serbia According to the Theirs Polltions Degree', *COLLECTION OF PAPERS—Faculty of Geography at the University of Belgrade: LVII*, 504.45.054. (497.11), 6-18.
- Paktunc, D., (1991). 'Characterization of mine wastes for prediction of acid mine drainage', *Environ. Imp. Mining Activ.* 19–40.
- Peterson, L.R., Trivett, V., Baker, A.J.M., Aguiar, C. and Pollard, A.J. (2003). 'Spread of Metals through an Invertebrate Food Chain as Influenced by a Plant That Hyperaccumulates Nickel'. *Chemoecology*, 13, 103-108.
- Phillips, C.J.C. and Tudoreanu, L. (2011). 'A Model of Cadmium in the Liver and Kidney of Sheep Derived from Soil and Dietary Characteristics'. *Journal of the Science of Food and Agriculture*, 91, 370-376. <http://dx.doi.org/10.1002/jsfa.4195>
- Pollard, A.J., Reeves, R.D. and Baker, A.J.M. (2014). 'Facultative Hyperaccumulation of Heavy Metals and Metalloids'. *Plant Science*, 217, 8-17. <http://dx.doi.org/10.1016/j.plantsci.2013.11.011>
- Reglero, M.M., Monsalve-González, L., Taggart, M.A. and Mateo, R. (2008). 'Transfer of Metals to Plants and Red Deer in an Old Lead Mining Area in Spain'. *Science of the Total Environment*, 406, 287-297. <http://dx.doi.org/10.1016/j.scitotenv.2008.06.001>
- Reglero, M.M., Taggart, M.A., Monsalve-González, L. and Mateo, R. (2009). 'Heavy Metal Exposure in Large Game from a Lead Mining Area: Effects on Oxidative Stress and Fatty Acid Composition in Liver'. *Environmental Pollution*, 157, 1388-1395. <http://dx.doi.org/10.1016/j.envpol.2008.11.036>
- Regulation on limit values of pollutants in surface and underground waters and sediment and deadlines for their achievement: (,Sl. gl. RS" 50/2012-10).
- Roggeman, S., van den Brink, N., Van Praet, N., Blust, R. and Bervoets, L. (2013). 'Metal Exposure and Accumulation Patterns in Free-Range Cows (*Bos taurus*) in a Contaminated Natural Area: Influence of Spatial and Social Behavior'. *Environmental Pollution*, 172, 186-199. <http://dx.doi.org/10.1016/j.envpol.2012.09.006>
- Sahoo, P.K. and Kim, K. (2013). 'A Review of the Arsenic Concentration in Paddy Rice from the Perspective of Geosciences'. *Geosciences Journal*, 17, 107-122. <http://dx.doi.org/10.1007/s12303-013-0004-4>
- Sajn, R., Aliu, M., Stafilov, T., Alijagić J., (2013). 'Heavy metal contamination of topsoil around a lead and zinc smelter in Kosovska Mitrovica/ Mitrovicë, Kosovo/Kosovë', *J. Geochem. Explor.* 134 1–16, <https://doi.org/10.1016/j.gexplo.2013.06.018>.
- Sánchez-Chardi, A., López-Fuster, M.J. and Nadal, J. (2007). 'Bioaccumulation of Lead, Mercury, and Cadmium in the Greater White-Toothed Shrew, *Crocidura russula*, from the Ebro Delta (NE Spain): Sex- and Age-Dependent Variation'. *Environmental Pollution*, 145, 7-14. <http://dx.doi.org/10.1016/j.envpol.2006.02.033>
- Sánchez-Chardi, A., Penarroja-Matutano, C., Ribeiro, C.A.O. and Nadal, J. (2007). 'Bioaccumulation of Metals and Effects of a Landfill in Small Mammals, Part II'. *The Wood Mouse, *Apodemus sylvaticus**. *Chemosphere*, 70, 101-109. <http://dx.doi.org/10.1016/j.chemosphere.2007.06.047>
- Street, R.A. (2012). 'Heavy Metals in Medicinal Plant Products: An African Perspective'. *South African Journal of Botany*, 82, 67-74. <http://dx.doi.org/10.1016/j.sajb.2012.07.013>
- International Conference Report INDUSTRIAL WASTE MANAGEMENT FOR TREPÇA ENTERPRISE <https://dokumen.tips/documents/trepca-conference-report.html?page=1>
- Van der Ent, A., Baker, A.J.M., Reeves, R.D., Pollard, A.J. and Schat, H. (2013). 'Hyperaccumulators of Metal and Metalloid Trace Elements': *Facts and Fiction. Plant and Soil*, 362, 319-334. <http://dx.doi.org/10.1007/s11104-012-1287-3>
- Wenzel, W.W. (2009). 'Rhizosphere Processes and Management in Plant-Assisted Bioremediation (Phytoremediation) of Soils'. *Plant and Soil*, 321, 385-408. <http://dx.doi.org/10.1007/s11104-008-9686-1>

## ACKNOWLEDGEMENTS

This research is conducted as a part of project No. TR-36017 Lead and zinc industry, consequences for the population and arrangement and protection of ecosystems and III 43007, the investigated of climate change and their impact on the environment, monitoring impact, adaptation and mitigation; This study is supported by the Ministry of Education, Science and Technological Development of the Republic of Serbia.

## BIOGRAPHY of the first author

**Irma Dervišević** was born in Gnjilane, Serbia, in 1964. She received a diploma in metallurgy engineering and a doctor of Environmental Protection Engineering in the University of Belgrade, at the Technological Metallurgical Faculty.



Her main areas of research include environmental protection, monitoring emission of pollution from industrial plants and landfills, cleaner technologies, etc. She is currently working as an Associate Professor at the Faculty of Technical Science in Kosovska Mitrovica, the University of Prishtina with temporary headquarters in Kosovska Mitrovica.





NATALIJA PETROVIĆ<sup>1</sup>  
DEJAN VASOVIĆ<sup>2</sup>  
NEMANJA PETROVIĆ<sup>3</sup>  
SANDRA STANKOVIĆ<sup>4</sup>

<sup>1,3,4</sup> Academy of Technical and  
Educational Vocational Studies  
<sup>2</sup> University of Niš,  
Faculty of Occupational Safety

<sup>1</sup>natalija.tosic@akademijanis.edu.rs

<sup>2</sup>dejan.vasovic@znrfak.ni.ac.rs

<sup>3</sup>nemanja.petrovic@akademijanis.edu.rs

<sup>4</sup>sandra.stankovic@akademijanis.edu.rs

## ANALYSIS OF RELEVANT INPUT PARAMETERS FOR LANDFILL LEACHATE MODELING

**Abstract:** *A special challenge in the municipal solid waste management system and in the context of environmental protection is the management of leachate emissions, which are indispensable elements of the landfill aging process. Evaluations of leachate regimes based on software simulations are becoming more significant in addition to conventional methods based on field measurements. Therefore, this paper provides input parameters for a simulation program used to assess leachate generation at landfill sites. An interactive program developed by Golder Associates on behalf of the Environment Agency, LandSim uses Monte Carlo probabilistic performance assessment models constructed for new and existing landfill sites. The most important input data needed to obtain valid output data on leachate production, chemistry, migration and leakage through engineered and non-engineered structures were analyzed in this paper, followed by leachate migration through the unsaturated zone to assess the ultimate impact on the aquifer.*

**Key words:** Environmental management, LandSim simulation model, landfill, leachate

## INTRODUCTION

The disposal of municipal solid waste to landfill sites is the most common waste disposal method in developing countries (Mishra, et al., 2016a) (Tošić, et al., 2020). When the improper management of landfills is present, high leachate leakage, from municipal solid waste which contains a broad mixture of chemical pollutants, can have adverse impacts on soils, plants, groundwater, aquatic organisms, and human health (Rathod, et al., 2013) (Christensen, et al., 2001). As a result, the monitoring of groundwater movement around the landfill becomes a necessity (Parhusip, et al., 2017).

Landfill leachate transport modelling typically involves two steps (Grzegorz, 2015):

1. the leachate generation and its leakage through the landfill liners
2. the transport and migration of the contaminants to an aquifer or compliance point.

Numerous numerical models have been developed to simulate landfill leachate transport in the subsurface (Mishra, et al., 2017). One of the numerical models used for leachate analysis is the LandSim simulation model. In this paper, the input parameters for LandSim modelling will be presented.

## LANDSIM SIMULATION MODEL

The LandSim model is a probabilistic performance assessment model for predicting the impacts of landfill

development on groundwater (Hall, 1998). It uses a contaminant-specific declining source term based on the results of standard up-flow percolation leaching tests and the Laplace transform technique is used to solve the advection-diffusion contaminant transport equation (Slack, et al., 2007). Very few studies have been conducted on landfill sites using the LandSim simulation model, which has applications for leachate transport modelling (Mishra, et al., 2017). The model was developed on behalf of the Environment Agency in the UK and can be used as a tool for optimising design and undertaking impact assessments. LandSim allows landfill operators and regulators to consider the environmental performance of different liners (e.g. compacted clay versus high-density polyethylene (HDPE) geomembranes/clay) and leachate collection systems, and to take account of the large variety of geological and hydrogeological regimes (Environment Agency, 2001). It essentially provides a formalized method of assessing liner leakage and contaminant migration, and the impact of leachate on groundwater (Hall, 1998). LandSim is used to predict leachate concentrations and elevations during the operational phase of the site, including changes in infiltration, declining source term within leachate and deteriorating leachate control systems (Sun, et al., 2019). LandSim is also used to measure advective fluxes from the landfill when leachate heads exceed groundwater levels in the surrounding clay subsoils and the potentiometric surface in the aquifer (Anon., 2009).



### RELEVANT INPUT PARAMETERS

LandSim uses the Monte Carlo simulation technique to select randomly from a predefined range of possible input values to create parameters for use in the model calculations (Golder Associates, 2006). The most relevant parameters needed to obtain valid results are data on water infiltration into the landfill body, cell geometry, leachate inventory, drainage system, engineered barrier, unsaturated pathway, vertical pathway and aquifer flow. A cartoon (Figure 1) guides us along the path of contaminant transport from the engineered landfill to a groundwater receptor.

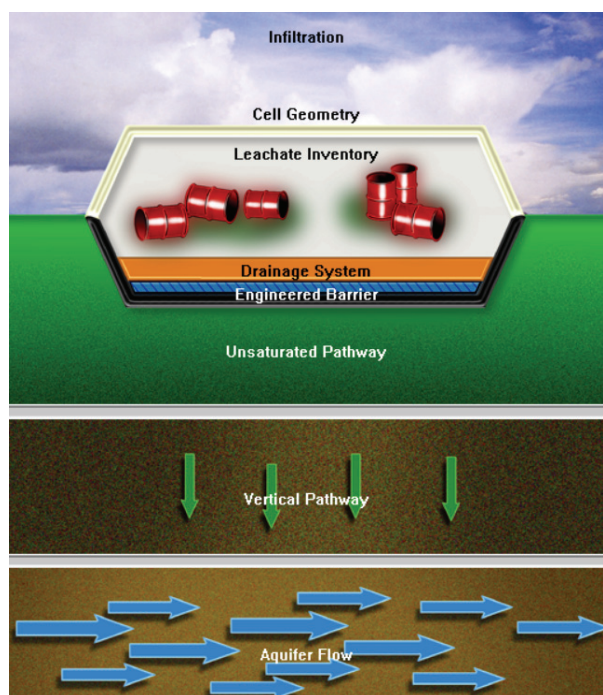


Figure 1. LandSim 2.5 conceptual model (Golder Associates, 2006)

At each stage along the pathway, it is possible to enter data that enables the simulator to determine the rate of contaminant migration.

#### Infiltration

The leachate circulation depends on the way of water migration in the landfill. The increase in rainfall contributes to the dilution of pollutants and as a result to the reduction of concentrations, which causes an increase in volume (Grzegorz, 2015). The infiltration option allows to define the rate of infiltration into the top area of the landfill under consideration. The infiltration required by the model is the effective rainfall. This is equivalent to the depth of water annually entering the waste pile per unit area. For the purposes of running LandSim, effective rainfall may be defined as precipitation less runoff, evaporation and evapotranspiration (Golder Associates, n.d.).

When choosing a value for infiltration, it should also consider fluid inflows into the landfill other than effective rainfall. These may include: the inflow of

groundwater into the sides of an unlined site, the inflow of groundwater from perched water tables, the presence of a leachate recirculation scheme and contributions made from the disposal of liquid waste (Golder Associates, n.d.).

LandSim calculations begin with the infiltration of water into the landfill, as this is the force driving contaminant leakage. LandSim assumes that the quoted infiltration rate is the only water source for the landfill and that the given infiltration rate applies over the full surface area of the facility as shown in Figure 2.

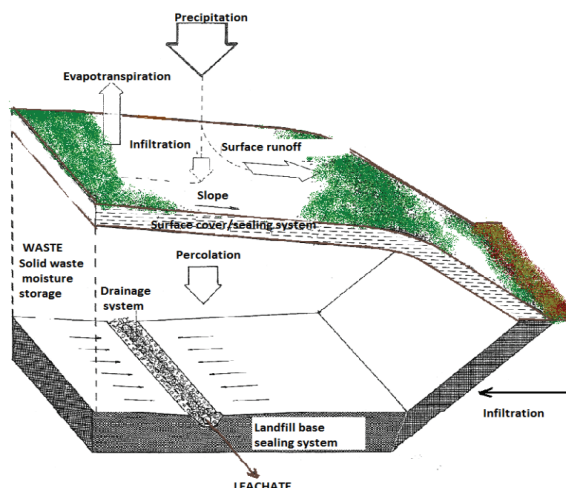


Figure 2. Infiltration surface area (Serdarevic, 2018)

Total infiltrating volume is obtained by multiplying the infiltration rate by the top area of the landfill. Because precipitation - and therefore infiltration - generally follows a normal distribution, a mean value and a standard deviation could be used to define the input distribution.

#### Cell Geometry

The cell geometry option allows us to define the geometry of the landfill under consideration as shown in Figure 3.

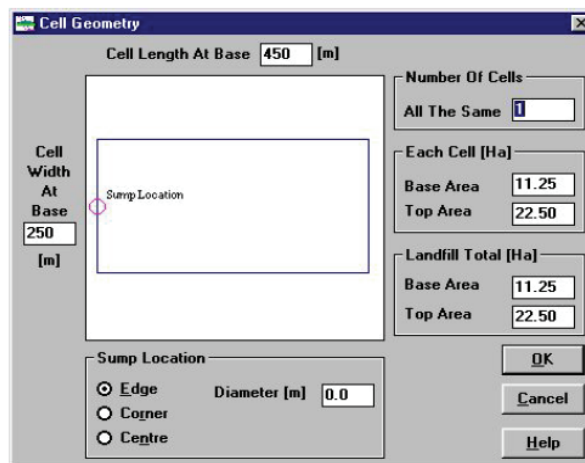


Figure 3. Dialogue box of Cell Geometry (Golder Associates, n.d.)

The LandSim program models a landfill as a number of identical cells. It is important to consider the number of

individual cells in a landfill because this affects the average distance to the leachate sump, which in turn affects the leachate head that builds up on the base of the landfill. The LandSim code assumes an orthogonal geometry for the cell shape being defined. If landfill cells are not orthogonal, then they should approximate their shape with a rectangle that has approximately the same length to-width ratio as the actual shape as well as the same area. The cell base area is automatically calculated from the input cell side lengths. This area should be made equal to the area through which vertical leakage will occur. If the area of side slopes is not negligible compared with the base of the cell, an estimate should be made of the total area that might contain standing leachate.

LandSim also requires the area of the top of the landfill to be defined. This area is used to determine the volume of infiltration into the landfill. The value may be entered for each landfill cell or for the total landfill. In either case, the other value will automatically be updated.

The values entered into the Cell Geometry window are those used in the leachate head and leakage calculation. Input parameters included in the cell geometry are final waste thickness in meters, waste porosity in fractions, waste dry density in kg/l and waste field capacity in fractions.

### Leachate Inventory

The source term describes the inventory in terms of concentrations of selected contaminants in the leachate and its availability for release.

The default inventory and concentrations for contaminants in LandSim are based on a large study of UK landfills (Robinson, 1995). Because no functional relationships that control the nature of the leachate chemistry have been identified yet, LandSim takes the approach that the leachate inventory should be treated as a random chance drawn from overall UK experience. That implies that there is an order of magnitude uncertainty about what leachate might be generated in any given landfill.

Typically, during the lifetime of the landfill the physical and chemical characteristics of the leachate being produced will change. One reason for the change in leachate concentration is a flushing-out of contaminants as infiltration passes through a landfill. To account for this process, a declining source term model has been included in LandSim (Walker, 1993). This assumes that the concentration of a contaminant at any time is related to its initial concentration according to the Eqn. (1,2) (Golder Associates, n.d.),

$$C_t = C_0^{-\lambda t} \tag{1}$$

$$\lambda = 1/(W_{thickness} \cdot W_{fc}) \tag{2}$$

where:

$C_t$  = concentration at time  $t$  [mg/l]

$C_0$  = initial concentration [mg/l]

$t$  = time [years]

$i$  = infiltration [m/year]

$W_{thickness}$  = waste thickness [m]

$W_{fc}$  = waste field capacity.

The waste field capacity is equivalent to the fraction of water that remains in the waste by volume under free draining conditions.

### Drainage System

The drainage system option allows us to define the proposed mechanism for collecting leachate from the base of the landfill (Golder Associates, 2006). The extent of leakage through the base of each cell of the landfill is directly proportional to the overlying head of leachate. This is a function of:

- the rate and distribution of infiltration to the landfill;
- the drainage system, if any, which has been installed below the waste to prevent the build-up of excessive head;
- the size of the landfill cell (when no piped drainage blanket is used).

With LandSim the infiltration rate is assumed to be consistent across the entire area of each phase of the landfill and, within each cell, the leachate drainage system is categorized as either:

- blanket drainage or as
- piped drainage.

Where no engineered drainage system has been installed the site is treated as a special case within the blanket drainage category. The blanket drainage and piped drainage systems are illustrated in Figure 4 and 5.

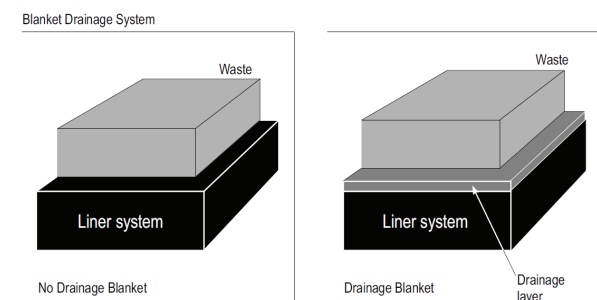


Figure 4. Schematic of alternative leachate drainage systems (Blanket drainage system) (Hughes, et al., 2007)

Where pipe drainage has not been installed, leachate is assumed to flow radially through the drainage medium (or waste if no engineered drainage has been installed) in the direction of a sump. When no engineered drainage system is present, the data requirements to calculate the head on the landfill base are:

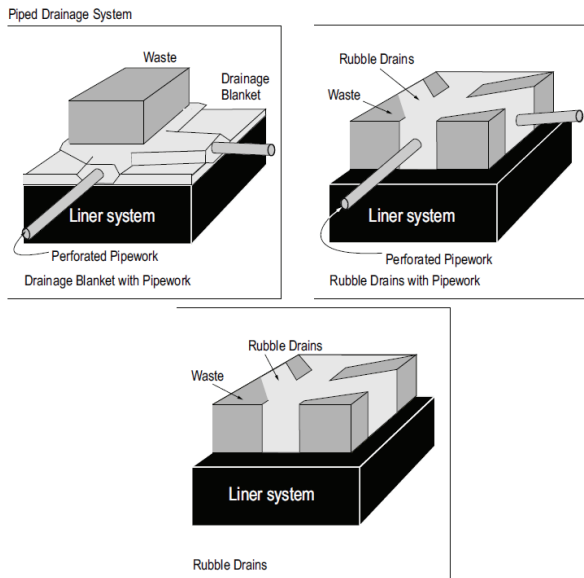
- the waste hydraulic conductivity in m/s
- landfill base slope towards the sump.

When a drainage blanket has been specified, the data requirements for calculating the head on the landfill base are:

- the blanket drain conductivity in m/s;
- the blanket thickness in m;
- landfill base slope towards the sump.

### Piped Drainage Systems

Modern landfills will normally incorporate drainage pipes so that the drainage pattern is characterized by the pipe layout rather than the sump position.



**Figure 5.** Schematic of alternative leachate drainage systems (Piped drainage system) (Hughes, et al., 2007)  
The choice between these alternative configurations is cost versus drainage efficiency.

### Engineered Barrier Systems

The engineered barrier models are the physical systems that prevent leachate from flowing freely into the underlying ground (Hassan, 2014).

Different phases can have different types of engineered barriers. This is quite likely if a multiple-phase landfill is developed over a long period of time. A menu of physical systems (liner designs) is offered and interest centres on how leachate leaks through these barriers, and the rate at which it occurs.

In the engineered barrier performance module of LandSim, it is assumed that the system is homogeneous and isotropic and that flow has reached a steady state. The calculation of leakage through the engineered barrier can be considered in two parts (Sun, et al., 2019):

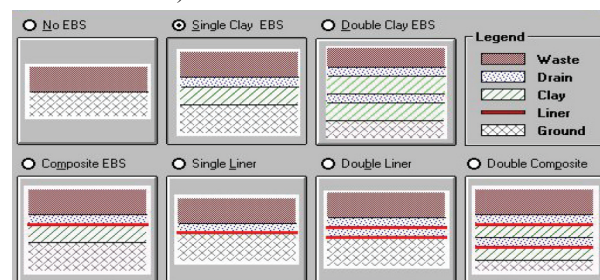
- Head of a leachate on the base of the facility, input directly into the leakage calculation. This calculation is independent of leachate chemistry and characteristics of the geosphere
- The flow rate of leachate leaking through the base of the facility, again independent of leachate chemistry.

The magnitude of this leakage depends on the head of the leachate, the characteristics of the liner system and the hydraulic conductivity of the underlying material.

This section looks at the methods of calculating leakage for various liners. The calculation is based on the infiltration into the landfill, the calculated head on the drainage system and the characteristics of any EBS present.

At present, seven types of liner systems are available in LandSim (illustrated in Figure 6). These are:

1. No EBS
2. Single Clay (Mineral Liner)
3. Double Clay (Mineral Liner)
4. Single Liner (Membrane Liner)
5. Double Liner (Membrane Liner)
6. Composite Liner (Mineral and Membrane Liner, including Geosynthetic Clay Liners)
7. Double Composite Liner (Mineral and Membrane Liner, including Geosynthetic Clay Liners)



**Figure 6.** Types of liner systems available in LandSim (Golder Associates, n.d.)

In the case of synthetic membrane systems, leakage is assumed to be entirely through defects and modelled using recent research on this topic from geosynthetic literature. For compacted lining systems, conventional uniform hydraulic flow is modelled.

### Geosphere Inputs

The geosphere inputs are used to calculate the rate of contaminant transport through the unsaturated and saturated zones away from the landfill. Leachate is assumed to pass vertically through the unsaturated zone and horizontally in the underlying saturated zone.

The 'Unsaturated Pathway' dialogue box is split into four main sections (Golder Associates, 2006):

- Geological Unit- the name of the geological unit that forms the unsaturated zone
- Geometry- pathway length, pathway porosity and moisture content of the unsaturated zone
- Hydraulic Properties- hydraulic conductivity of the unsaturated zone
- Flow Model- Porous Medium or Dual Porosity

The 'Vertical Pathway' dialogue box should be completed if the aquifer underlying the landfill is overlain by saturated material through which the direction of contaminant transport is predominantly vertically downwards. This scenario may be realised when a landfill is constructed over mudstone strata that hydraulically confines an aquifer.



The 'Vertical Pathway' dialogue box is split into three main sections;

- Geological Unit- allows the geological unit to be specified, which includes the saturated vertical pathway.
- Geometry- pathway length (the thickness of the low permeability strata beneath the water table where vertical flow occurs) and pathway porosity (used to calculate travel time.) of the saturated vertical pathway
- Hydraulic Properties- hydraulic conductivity of the vertical pathway

### Aquifer Pathway

LandSim requires certain parameters to calculate lateral vertical and horizontal contaminant transport via the aquifer pathway beneath the landfill. The 'Aquifer Pathway' dialogue box is split into three main sections:

- Geological Unit- the name of the geological unit that is considered to be the aquifer.
- Geometry - input data that describes the geometry of the aquifer pathway such as length (the distance, measured along a groundwater flow line, between the landfill and the receptor), width (calculate the volume of groundwater underflow) and thickness of the aquifer mixing zone
- Hydraulic Properties- calculate the rate at which groundwater underflows and hence the amount by which the leachate is diluted in the aquifer

## RESULTS AND DISCUSSION

All output from LandSim is in the form of probabilistic plots, expressed as frequency, cumulative or reverse cumulative diagrams and/or tabular summaries printed in report format with the appropriate quality assurance documentation.

A statistical representation of results is also available in LandSim, simulator. All the graphical results are available in statistical format:

- hydraulics (head-on EBS, leakage through EBS, dilution and aquifer flow);
- travel time (retarded and unretarded travel times to the base of the unsaturated zone and to the off-site compliance point);
- concentration (at source, at the base of the unsaturated zone, at the Monitor Well and at the off-site Compliance Point).

The height, or head, of leachate above the top of the engineered barrier system (EBS) varies from place to place within the landfill. LandSim reports the maximum value expected to give you an index of the overall situation (Figure 7).

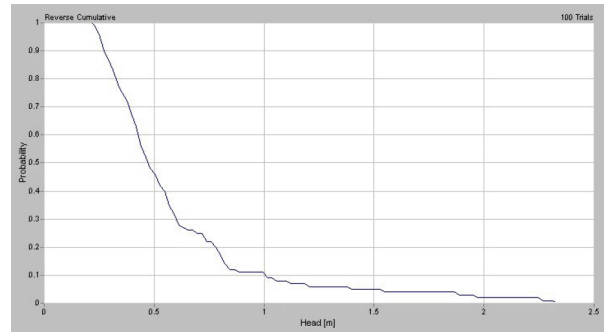


Figure 7. Maximum head in EBS example (Golder Associates, n.d.)

The example plot above shows that there is a probability of 0.1 (10% chance) that the maximum head will be greater than 1m.

LandSim plots the predicted contaminant concentrations at five discrete times in the future. The default intervals are 30, 100, 300 and 1000 years and infinity and they are shown in Figure 8.

The Time History plot also shows the predicted contaminant concentrations against time for selected uncertainty levels (Figure 8).

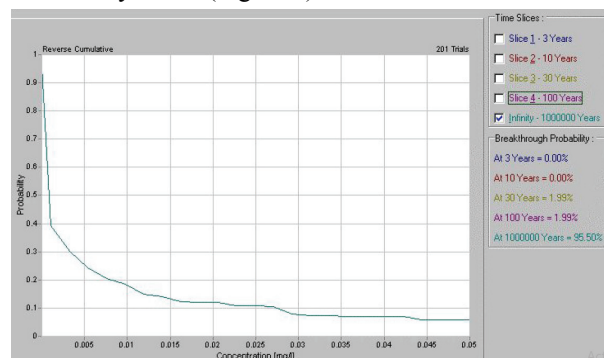


Figure 8. Probability of breakthrough at the Compliance Point in time slice of infinity example (Golder Associates, n.d.)

The tabulated breakthrough probabilities show that the probability of breakthrough at the Compliance Point increases with time, from zero at 3 years, to 1.99% at 30 years and 100 years.

LandSim uses a variety of mathematical techniques to calculate ultimate solute concentration distributions over time. The program combines analytical and semi-analytical models of groundwater flow with analytical models of solute transport. Most importantly, the predictions of the flow model should be checked before the solute transport calculations can be believed. Both head and flow rates should lie within reasonable ranges; unrealistically high or low values are probably diagnostic of the model's inapplicability or incorrect parameterisation.

## CONCLUSION

Verification has demonstrated that LandSim works correctly when compared with hydrogeological theory. Validation of LandSim has been undertaken to

investigate the quality of LandSim output by modelling case studies, that take into account the uncertainty in available data, with measured field data. It has demonstrated that LandSim predicts ranges for leachate head, contaminant travel times and contaminant concentrations that encompass measured data and are consistently conservative at the 95th percent confidence limit. Validation has highlighted the need to understand the limitations of the LandSim conceptual model and the importance of site-specific data.

## REFERENCES

- Anon., 2009. *Fingal landfill project- hydrogeological risk assessment*, Fingal: Fingal County Council.
- Christensen, T. et al., 2001. Biogeochemistry of landfill leachate plumes. *Appl Geochem*, p. 659–718.
- Environment Agency, 2001. *Guidance on the assessment and investigation of subsurface analytical contaminant fate and transport models.*, s.l.: National Groundwater & Contaminated Land Centre.
- Golder Associates, 2006. *LandSim 2.5 groundwater risk assessment tool for landfill design*, s.l.: Environment Agency.
- Golder Associates, n.d. *LandSim 2 manual*, UK: Environment Agency R&D Publication 120.
- Grzegorz, G., 2015. The influence of infiltration of leachate from landfills on the changes of chemical parameters of the soil. *Journal of Ecological Engineering*, pp. 198-205.
- Hall, D., 1998. *Dealing with uncertainty in the assessment of groundwater impacts from landfills: the LandSim model*. Portlaoise, International Association of Hydrogeologists, pp. 1-12.
- Hassan, A., 2014. *Hydraulic performance of compacted clay liners (CCLs) under simulated landfill conditions*, Ottawa: Carleton University Ottawa.
- Hughes, K., Christy, A. & Heimlich, J., 2007. *Landfill types and liner systems*, Ohio: Ohio State University Extension Fact Sheet.
- Mishra, H., Karmakar, S., Kumar, R. & Kadambala, P., 2017. A long-term comparative assessment of human health risk to leachate-contaminated groundwater from heavy metal with different liner systems. *Environ Sci Pollut Res*, pp. 1-13.
- Mishra, H., Rathod, M., Karmakar, S. & Kumar, R., 2016a. A framework for assessment and characterisation of municipal solid waste landfill leachate: an application to the Turbhe landfill, Navi Mumbai, India. *Environmental Monitoring and Assessment*, pp. 1-26.
- Parhusip, J., Harijoko, A., Putra, D. & Suryanto, W., 2017. *Assessment of leachate infiltration from Piyungan landfill using electrical resistivity method*. s.l., American Institute of Physics, pp. 030008-1–030008-4.

- Rathod, M., Mishra, H. & Karmakar, S., 2013. Leachate characterization and assessment of water pollution near municipal solid waste landfill site. *Int J Chem Phys Sci*, p. Special Issue.
- Robinson, H., 1995. *A review of the composition of leachates from domestic wastes in landfill sites*, s.l.: Department of the Environment report no CWM 072/95.
- Serdarevic, A., 2018. Landfill leachate management – control and treatment. *Advanced Technologies, Systems, and Applications II*, pp. 618-632.
- Slack, R., Gronow, J., Hall, D. & Voulvoulis, N., 2007. Household hazardous waste disposal to landfill: using LandSim to model leachate migration.. *Environ Pollut*, pp. 501-509.
- Sun, X. et al., 2019. Evolution of geomembrane degradation and defects in a landfill: Impacts on long-term leachate leakage and groundwater quality. *Journal of Cleaner Production*, pp. 335-345.
- Tošić, N., Vasović, D., Nešić, B. & Petrović, N., 2020. Leachate treatment by reverse osmosis method-regional sanitary landfill “Zeljkovac” case study. *Facta Universitates, Working and Living Environmental Protection*, pp. 175-184.
- Walker, N., 1993. *Landfill leachate control: diagnosis and prognosis*, London: I.W.M. London & Southern Counties Centre.

## ACKNOWLEDGEMENTS

This paper is a result of research funded by the Ministry of Education, Science and Technological Development of the Republic of Serbia.

## BIOGRAPHY of the first author

**Natalija Petrović** was born in Niš, Serbia, in 1993.

She received master diploma in Environmental safety at Faculty of Occupational Safety in Niš, University of Niš. Now she is at PhD study program of Environmental Safety Engineering at the Faculty of Occupational Safety in Nis, University of Niš.

Her main areas of research include environmental protection, environmental management and water protection.

She is currently working as an assistant at the Academy of Technical and Educational Vocational Studies - Department of Nis.





DRAGAN ADAMOVIĆ<sup>1</sup>  
GORAN VUJIĆ<sup>2</sup>  
SAVKA ADAMOVIĆ<sup>3</sup>

<sup>1,2,3</sup>University of Novi Sad,  
Faculty of Technical Sciences

<sup>1</sup>draganadamovic@uns.ac.rs

<sup>2</sup>goranvujic@uns.ac.rs

<sup>3</sup>adamovicsavka@uns.ac.rs

## PARTICULATE MATTER AT AN OPEN DUMPING SITE

**Abstract:** Large quantities of solid waste are generally disposed of in landfills and they represent a potentially strong emission source of inhalable particulate matter (PM) and other pollutants, such as sulphur, carbon oxides, and methane. Emissions of particulate matter in landfills result from resuspension from the disposed waste and many other activities, such as mechanical recycling and composting, coating residues, waste unloading and sorting, and waste transport by trucks. Other air pollutants and greenhouse gases originate from the natural degradation of organic matter or the burning of landfill wastes. Elevated concentration levels cause health impacts on humans and the environment. Measurements of concentration levels of PM<sub>10</sub> were performed in an open dumping site near Kać (Serbia) and the background location, 1 km away from the open dumping site. Measurements of PM<sub>10</sub> concentration levels were performed using sensor devices. Elevated concentration levels of PM<sub>10</sub> were detected in the open dumping site during different time periods. It was observed that the meteorological conditions (wind velocity and temperature) considerably influence the PM<sub>10</sub> concentrations. A comparison between the concentration levels of PM<sub>10</sub> at the open dumping site and a background location indicates the impact of the activities on local concentrations of PM<sub>10</sub> at the open dumping site. No correlation was observed between the measurements at the open dumping site and the background location.

**Key words:** air pollution, particulate matter, open dumping, solid waste

## INTRODUCTION

Modern lifestyle affects the increase in the total amount of solid waste generated over the years (Yadav, 2015). In order to reduce the environmental impact from the deposition of waste in landfills, numerous governments throughout the world have planned to significantly increase the recycling of solid waste (Cudjoe et al., 2021; Omran et al., 2009). To implement the plans, new waste recycling facilities were built, and more workers involved in waste sorting and recycling were hired during the past decade. Many scientific studies emphasize the fact that exposure to airborne microorganisms and toxic products is an essential factor causing many health problems among workers during waste collection, waste sorting, and time spent in recycling plants (Poulsen et al., 1995). Workers employed at transfer stations, landfills, and incineration plants may experience an increased risk of pulmonary disorders and gastrointestinal problems (Jayakrishnan et al., 2013). High concentrations of total airborne dust, bacteria, and numerous chemical substances have been reported (Madsen et al., 2021). The concentration levels are considered to be sufficiently high to cause adverse health effects. In addition, an increased incidence of lower back injuries, probably due to heavy

lifting during work, has been reported among workers at landfills and in sorting and incineration plants (Reddy and Yasobant, 2015).

However, despite significant efforts to make progress in this field, there are still many unorganized dumps in Serbia and other developing countries, which pose a great danger to people who dispose of waste and those who live in the immediate vicinity.

Waste generation is increasing in complexity and quantity all over the world, with growing urbanization, industrialization, and population. The concentration of people influences the generation of larger amounts of waste materials from human activities and interactions. These wastes, which generally include farmyard products and biodegradables, and toxic and infectious materials derived from both industrial and domestic sources, are usually dumped in open landfills. Open dumping of solid waste is a major public health concern and a source of environmental degradation in Serbia and other developing countries. Effective solid waste management (SWM) is a principal challenge in urban areas. Furthermore, living close to landfill sites is a known health threat. A population living and working in the vicinity of solid waste processing and disposal

facilities is exposed to environmental health threats (Palmiotto et al., 2014). This is due to the emission of harmful gases and air pollutants (landfill gas containing methane, carbon dioxide, hydrogen sulphide, and other contaminants, including volatile organic compounds, bioaerosols, and particulate matter) or due to polluted soil and water. Inappropriate and inefficient handling of waste disposal has a damaging impact on the environment and human health.

Although landfills generate odour problems, major health and safety challenges in open dumpsites may include the emission of dangerous but odourless gases, such as methane and carbon dioxide (CO<sub>2</sub>). These gases, together with trace amounts of volatile organic compounds (VOCs), form what is commonly referred to as landfill gas (LFG). The VOCs contain toxic air pollutants such as benzene, toluene, ethylbenzene, and xylene (BTEX) (Durmusoglu et al., 2010; Lakhout and Alsulami, 2020). These 'invisible' gases are also accompanied by visible emissions of dust and airborne particulate matter (PM<sub>10</sub>). PM<sub>10</sub> is found in the exhaust fumes of the trucks that transport waste to the landfill and leachate away from the landfill (Chalvatzaki et al., 2015). Dust and PM<sub>10</sub> emissions are also generated from the movement of trucks and other vehicles that travel on the unpaved access roads to most landfills.

LFG is also produced by the bacterial degradation of garbage and may consist of up to 50% CO<sub>2</sub>, 30-60% methane (CH<sub>4</sub>), small quantities of VOCs, and other hazardous air pollutants (HAPs) (Vieru, 2020). LFG may also contain minute quantities of hydrogen sulphide (H<sub>2</sub>S), ammonia (NH<sub>3</sub>), carbon monoxide (CO), and nitrogen (N<sub>2</sub>) from air infiltration and persistent bio-accumulative toxic compounds.

Inhabitants living close to landfill sites show concern due to several hazardous pollutants from landfills. Some other contaminants associated with the deposition of waste in landfills include dust, rodents, accidental landfill fires, etc. (Okeke and Armour, 2000). The characteristics that influence the by-product or emissions from landfills include the category and quantity of deposited waste, the age of the landfills, and the climatic conditions of the landfill sites. In addition, complex chemical and microbiological reactions within the landfill frequently lead to the generation of multiple gaseous pollutants, persistent organic pollutants (such as dioxins and polycyclic aromatic hydrocarbons), heavy metals, and particulate matter (Mohammed et al., 2020).

Continuous inhalation of methane by humans can induce loss of coordination, nausea, vomiting, and exposure to high methane concentrations can cause death (Health Protection Agency, 2011). Acidic gases such as nitrogen dioxide, sulphur dioxide, and halides have detrimental effects on the health and environment when present. Investigations have shown that when nitrogen dioxide and sulphur dioxide are inhaled or ingested by humans, manifestations such as nose and

throat irritations, bronchoconstriction, dyspraxia, and respiratory infections prevail, mostly in asthmatic patients (Mataloni et al., 2016). These effects can initiate asthma attacks in asthmatic patients. In addition, high contact with NO<sub>2</sub> by humans increases the susceptibility to respiratory infections. In addition, when heavy metals are ingested or inhaled, humans are at risk of decreased lung function, asthma, ataxia, paralysis, emphysema, and lung cancer. Waste management has been closely related to biological threats. The decomposition of waste materials in a landfill, vehicle exhaust fumes, and favourable weather conditions can lead to the generation of bioaerosols and biological agents such as bacteria, fungi, and volatile compounds. Exposure to bioaerosols has been associated with various respiratory health diseases, which can provoke airway inflammation. Communities living closer to landfill sites have reported cancer and respiratory allergies.

Much attention has been given to landfill gas emissions due to the climatic impact of these gases and their potential for energy production (Khoiron et al., 2020; Tian et al., 2013). However, particulate matter (PM) also affects local air pollution and people's and workers' health. Therefore, it is essential to analyze the influence of MSW landfill activities on the ambient PM level.

Particulate matter is a complex mixture of different chemical components. An essential aspect of PM investigation is the complexness of its physicochemical characteristics, its numerous sources, morphology, and its dynamics linked with particle size (Bae and Hong, 2018). Ambient air quality standards have been included at the national and international levels to protect human health and the environment. The threshold pollutant concentrations defined in the legislation are based on a detailed review of the available scientific information related to their influences on human health.

The principal path for the PM to enter people's bodies is via the respiratory system. The health effects of PM are characterized by particle size distribution, chemical and microbiological concentration, and composition. The ambient PM levels, specifically the PM<sub>10</sub> particles, and especially PM<sub>2.5</sub>, pose a great hazard to people's and workers' health because they pass through the filtration mechanisms in the upper respiratory tract and penetrate through the larynx to the lower airways (Bae and Hong, 2018). Legislation rules for PM<sub>10</sub> concentration are proposed by the World Health Organization, the European Union (EU), and the United States Environmental Protection Agency. In the European Union (EU), the roles, goals, and methods of air quality management are determined by EU directive 96/62/EC and the later daughter directives that describe the objectives for air protection policy and standards for EU member states as well as candidate states, such as Serbia, as the platform for air quality assessment. For PM<sub>10</sub>, the obligatory standards have been

established at levels of  $40 \mu\text{g}/\text{m}^3$  (annual limit value for the protection of human health) and  $50 \mu\text{g}/\text{m}^3$   $\text{PM}_{10}$ , not to be exceeded more than 35 times within a calendar year (24-h limit value for the protection of human health) (Iriti et al., 2020).

In the current study, the  $\text{PM}_{10}$  concentrations in an open dump site (Kać, Serbia) are measured, and the importance of different  $\text{PM}_{10}$  sources is examined. Comparison has also been performed for  $\text{PM}_{10}$  concentrations in a background site several kilometres away from the dump.

## MATERIALS AND METHODS

### Description of the open dumping site

In order to determine the concentration levels of particulate matter in unregulated dumping sites and assess the impact on the immediate environment, an unregulated landfill near the settlement of Kać was selected. The dumping site is located approximately 10 km from Novi Sad and 7 km from the regional landfill. The residents of Kać most often dispose of construction waste at the dumping site, which creates higher concentration levels of particulate matter. However, corpses of dead animals and municipal waste can often be found in an unorganized landfill, despite the organized collection by the municipal utility company JKP Čistoća, Novi Sad. The disposal site is accessed mainly from an asphalted road and partly from an unpaved section. Within the body of the landfill, the roads used by machines that deliver waste are unpaved, so large amounts of dust are raised by the machines.



Figure 1. Dumpsite location

### Measurement methodology

Particulate matter measurements were performed simultaneously on three locations at the open dumping site and at a background location located 1 km away from the site in order to create background reference values for the  $\text{PM}_{10}$  concentration levels in the general area of the dumping site.

The  $\text{PM}_{10}$  measurements in the dumping site and the background location were performed using the sensor aerosol monitor. This portable laser-photometer measures aerosol concentration levels and requires a constant power source. The Aerosol Monitor provides reliable exposure assessment by measuring particle concentrations corresponding to  $\text{PM}_{10}$ ,  $\text{PM}_{2.5}$ , and  $\text{PM}_1$  (respirable size fractions). The measurements are based on  $90^\circ$  light scattering. A pump draws the sample aerosol through an optics chamber where light scatters are measured, while a sheath air system isolates the aerosol in the chamber to keep the optics clean. Measurements were conducted simultaneously at the sites within the landfill and the background location. The devices are in constant communication with the database. The values of the concentration levels are read every two minutes so that practically every operation is accompanied by the corresponding measured values of the PM concentrations.

Measurements of the concentration levels of particulate matter from the  $\text{PM}_{10}$  category were carried out for seven days, from 2 to 8 August 2021, to determine the periods with the highest daily and weekly concentrations of  $\text{PM}_{10}$ . In addition to  $\text{PM}_{10}$  concentration levels, meteorological parameters were also monitored: temperature, air humidity, and wind speed, in order to determine the correlation between these parameters and the concentration levels of dusty substances.

## RESULTS AND DISCUSSION

The average measured daily concentration values at the dump site and the background location by day are shown in Figure 2.

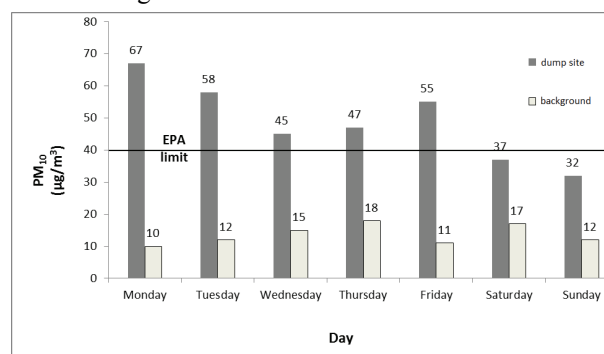


Figure 2. Average  $\text{PM}_{10}$  concentrations per day

The measured  $\text{PM}_{10}$  concentration values indicate the fact that the average daily values at the landfill are higher than the concentration values recommended by international professional organizations. The exceedance is significantly higher during weekdays compared to weekend days, primarily due to the higher level of activity at the landfill. The measured values at the background location are below the recommended daily value and at a uniform level throughout the entire series of measurements. Therefore, we can conclude that high values of  $\text{PM}_{10}$  concentrations at the landfill

do not affect concentration levels at the background location.

Figure 3 shows the average concentration values per hour during the day on the body of the dump. It can be seen that the highest concentration values were detected during the afternoon hours, primarily as a result of a higher level of activity on the body of the dump. PM<sub>10</sub> concentration values during the afternoon hours largely exceed the recommended limit value.

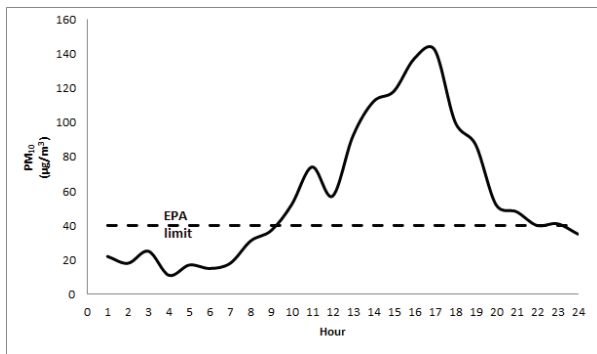


Figure 3. Average PM<sub>10</sub> concentration values per hour

The measurements were carried out during windy, hot, and dry summer days, which resulted in higher values of PM<sub>10</sub> concentrations. High concentration levels are often the result of the resuspension of powdery substances due to activity on the body of the dump site and strong air currents.

Figure 4 shows the relationship between PM<sub>10</sub> concentration levels and wind velocity.

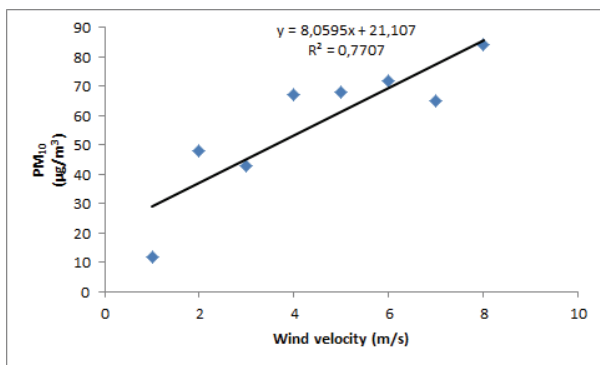


Figure 4. Influence of wind velocity on PM<sub>10</sub> concentration

An increase in PM<sub>10</sub> concentration levels in the air can be observed with an increase in wind speed due to the resuspension of dusty substances during dry summer days.

Considering that the measurements were carried out in the summer months, the ambient air temperatures varied from 24 to 40°C. Therefore, during the research, the influence of temperature on PM<sub>10</sub> concentration

levels was monitored. The results of measuring the effect of temperature on PM<sub>10</sub> concentration levels are shown in Figure 5.

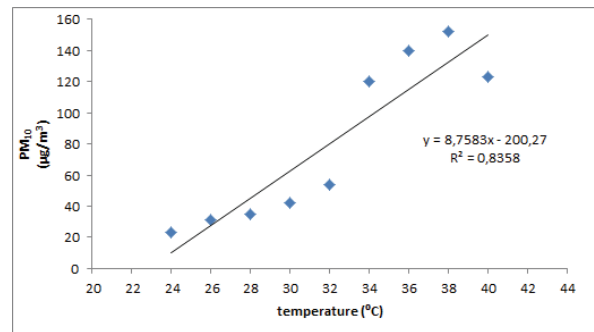


Figure 5. Influence of temperature on PM<sub>10</sub> concentration

Based on the measured values of PM<sub>10</sub> concentrations, it can be concluded that as the ambient air temperature increases, the PM<sub>10</sub> concentrations in the air also increase. Furthermore, such a conclusion can be made conditionally in this case, given that the conditions of the highest ambient temperatures coincide with the period of greatest activity at the dump site itself.

## CONCLUSION

In Serbia, almost every local community has its landfill. The problem is that the existing local landfills are unorganized, operate at full capacity, and most do not meet even the minimum environmental criteria. As a result of irresponsible waste management, about 40% of the generated municipal waste ends up in unorganized landfills and directly affects air, soil, and watercourse pollution. The following conclusions were drawn based on the results of the monitoring campaign at the non-sanitary dumpsite near Kač and the background location in the settlement itself. Namely, a comparison between the landfill PM<sub>10</sub> measurements and PM<sub>10</sub> measurements performed at the background station revealed that the elevated PM<sub>10</sub> concentrations at the landfill result from dump site operations and dust resuspension. Finally, the influence of meteorological parameters on the PM levels at the dump site was examined, and it was found that elevated temperature and wind speed values resulted in higher PM<sub>10</sub> concentrations.

## REFERENCES

- Bae, S., Hong, Y.C., 2018. Health effects of particulate matter. *J. Korean Med. Assoc.*
- Chalvatzaki, E., Glytsos, T., Lazaridis, M., 2015. A methodology for the determination of fugitive dust emissions from landfill sites. *Int. J. Environ. Health Res.*
- Cudjoe, D., Wang, H., Zhu, B., 2021. Assessment of the potential energy and environmental benefits of solid waste recycling in China. *J. Environ. Manage.*



Durmusoglu, E., Taspinar, F., Karademir, A., 2010. Health risk assessment of BTEX emissions in the landfill environment. *J. Hazard. Mater.*

Health Protection Agency. Impact on Health of Emissions from Landfill Site, Advice from the Health Protection Agency. 2011. Available online: [https://assets.publishing.service.gov.uk/government/uploads/system/uploads/attachment\\_data/file/334356/RCE-18\\_for\\_website\\_with\\_security.pdf](https://assets.publishing.service.gov.uk/government/uploads/system/uploads/attachment_data/file/334356/RCE-18_for_website_with_security.pdf) (accessed on 26. October 2022).

Iriti, M., Piscitelli, P., Missoni, E., Miani, A., 2020. Air pollution and health: The need for a medical reading of environmental monitoring data. *Int. J. Environ. Res. Public Health*.

Jayakrishnan, T., Jeeja, M., Bhaskar, R., 2013. Occupational health problems of municipal solid waste management workers in India. *Int. J. Environ. Health Eng.*

Khoiron, K., Probandari, A.N., Setyaningsih, W., Kasjono, H.S., Setyobudi, R.H., Anne, O., 2020. A review of environmental health impact from municipal solid waste (MSW) landfill. *Ann. Trop. Med. Public Heal.*

Lakhout, A., Alsulami, B.T., 2020. Evaluation of risk assessment of landfill emissions and their impacts on human health. *Arab. J. Geosci.*

Madsen, A.M., Raulf, M., Duquenne, P., Graff, P., Cyprowski, M., Beswick, A., Laitinen, S., Rasmussen, P.U., Hinker, M., Kolk, A., Górný, R.L., Oppliger, A., Crook, B., 2021. Review of biological risks associated with the collection of municipal wastes. *Sci. Total Environ.*

Mataloni, F., Badaloni, C., Golini, M.N., Bolignano, A., Bucci, S., Sozzi, R., Forastiere, F., Davoli, M., Ancona, C., 2016. Morbidity and mortality of people who live close to municipal waste landfills: A multisite cohort study. *Int. J. Epidemiol.*

Mohammed, A.A., Iniaighe, P.O., Abu, T.O., Bello, M.O., Abdulkadir, M.D., 2020. Source analysis of heavy metals and polycyclic aromatic hydrocarbons from a popular dumpsite, Lagos state, Nigeria. *J. Turkish Chem. Soc. Sect. A Chem.*

Okeke, C.U., Armour, A., 2000. Post-landfill siting perceptions of nearby residents: A case study of Halton landfill. *Appl. Geogr.*

Omran, A., Mahmood, A., Abdul Aziz, H., Robinson, G.M., 2009. Investigating households attitude toward recycling of solid waste in Malaysia: A case study. *Int. J. Environ. Res.*

Palmiotto, M., Fattore, E., Paiano, V., Celeste, G., Colombo, A., Davoli, E., 2014. Influence of a municipal solid waste landfill in the surrounding environment: Toxicological risk and odor nuisance effects. *Environ. Int.*

Poulsen, O.M., Breum, N.O., Ebbenhøj, N., Hansen, Å.M., Ivens, U.I., van Lelieveld, D., Malmros, P., Matthiasen, L., Nielsen, B.H., Nielsen, E.M., Schibye, B., Skov, T., Stenbaek, E.I., Wilkins, C.K., 1995. Collection of domestic

waste. Review of occupational health problems and their possible causes. *Sci. Total Environ.*

Reddy, E., Yasobant, S., 2015. Musculoskeletal disorders among municipal solid waste workers in India: A cross-sectional risk assessment. *J. Fam. Med. Prim. Care.*

Sharma, A., Gupta, A.K., Ganguly, R., 2018. Impact of open dumping of municipal solid waste on soil properties in mountainous region. *J. Rock Mech. Geotech. Eng.*

Tian, H., Gao, J., Hao, J., Lu, L., Zhu, C., Qiu, P., 2013. Atmospheric pollution problems and control proposals associated with solid waste management in China: A review. *J. Hazard. Mater.*

Vieru, D., 2020. Mathematical Modeling of Landfill Gas (MSW)—Production of Gas with Methane Gas Content from Landfills (MSW). *J. Geosci. Environ. Prot.*

Yadav, R., 2015. Solid waste management. *Pollut. Res.*

## ACKNOWLEDGEMENTS

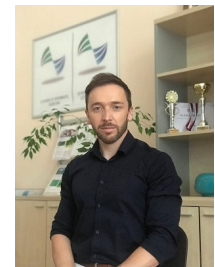
The activities were implemented within the global program "Migration for Development" (MFD) implemented in Serbia by Deutsche Gesellschaft für Internationale Zusammenarbeit GmbH (GIZ). The program is part of a broader initiative "Back to New Opportunities" by the German Federal Ministry for Economic Cooperation and Development.

## BIOGRAPHY of the first author

Dragan Adamović was born in Subotica, Serbia, in 1976.

He received his MSc degree from the Faculty of Technology and his Ph.D. in environmental engineering from the University of Novi Sad, Faculty of Technical Sciences. His main areas of research include air pollution and other topics from the field of environmental engineering.

He is currently working as an Associate Professor at the Faculty of Technical Sciences in Novi Sad, University of Novi Sad.







ANA VUKADINOVIĆ<sup>1</sup>  
JASMINA  
RADOSAVLJEVIĆ<sup>2</sup>  
AMELIJA ĐORĐEVIĆ<sup>3</sup>  
MILAN PROTIĆ<sup>4</sup>

<sup>1,2,3,4</sup> University of Niš,  
Faculty of Occupational Safety

<sup>1</sup>ana.vukadinovic@znrfak.ni.ac.rs  
<sup>2</sup>jasmina.radosavljevic@znrfak.ni.ac.rs  
<sup>3</sup>amelija.djordjevic@znrfak.ni.ac.rs  
<sup>4</sup>milan.protic@znrfak.ni.ac.rs

## ENERGY PERFORMANCE IMPACT OF PHASE-CHANGE MATERIALS IN FAÇADE WALLS OF RESIDENTIAL BUILDINGS

**Abstract:** Phase-change materials (PCMs) for latent passive thermal storage are used to increase the building's heat inertia. They are often positioned within the building structures, such as floors, ceilings, walls, etc. This paper analyzes PCM usage in façade walls of detached residential buildings. The study focuses on the buildings' energy performance in terms of heating and cooling over a period of one year, depending on the type of PCM within the façade wall system. Contingent on the climate and buildings' energy needs over a one-year period, PCMs have different impacts on buildings' energy performance. In this study, the considered model of a building is located in Niš, Serbia, a city with a Cfa climate according to the Köppen classification. To determine the impact of PCMs on energy consumption, reference model FW0 was developed with a façade wall that does not contain any PCM. Dynamic EnergyPlus™ simulations were performed for the reference model and the model variants containing PCMs to ascertain the energy required for heating, the energy required for cooling, and the total energy required for heating and cooling..

**Key words:** energy performance, PCM, residential buildings, façade wall

### INTRODUCTION

Energy consumption in building design and construction is approximately 40%, which results in a number of environmental impacts. Most energy in buildings is consumed on heating and cooling to provide comfort, and according to predictions, by 2050 energy consumption for heating and cooling will increase by 12% and 37%, respectively (Suresh, Kumar Hotta and Saha, 2022).

Phase-change materials (PCMs) have a wide application in building design and construction, because they can influence the regulation of thermal energy processes and latent storage of larger heat quantities compared to other materials in terms of proportional volume (Suresh, Kumar Hotta and Saha, 2022). During daytime, PCMs accumulate heat by changing their phase in order to transfer that heat to the connected room during the night and thus reduce heating or cooling energy consumption (Đuraković, 2020). PCMs can be classified as organic, inorganic, and eutectic (Wang *et al.*, 2022). The choice of PCM to be used in a building depends on its thermodynamic (phase-change temperature, thermal conductivity, specific heat capacity), chemical (stability, corrosion resistance, flammability, toxicity), kinetic (supercooling property and crystallisation), and techno-economic characteristics (Suresh, Kumar Hotta and Saha, 2022).

Determination of optimal phase-change temperature of PCMs is complex and studies have shown that the difference between outdoor and phase-change temperature only has to be 3°C to 5°C in order for sufficient heat exchange to take place. Optimal phase-change temperatures range from 19°C to 30°C depending on outdoor climate conditions (Cai *et al.*, 2021). On the other hand, when determining optimal temperature, it is necessary to consider the desired indoor temperatures in addition to outdoor climate data. This paper examines the impact of using different PCMs in façade walls on the energy properties of a detached building in the climate conditions of Niš, Serbia.

### METHODOLOGY

EnergyPlus™ software (Energy, 2019) was used in this study to determine the energy requirements of the detached residential building. The software utilises the method of detailed dynamic simulation and contains the *conduction finite difference* (CondFD) algorithm for the simulation of PCMs (U.S. Department of Energy, 2019). To calculate the enthalpy, semi-implicit formulation was applied. The input data required for a detailed dynamic simulation include the building model geometry, meteorological data for the location, data on the structure and composition of the thermal envelope, transparent and opaque envelope elements, building

heating and cooling system, and building utilisation regime, i.e. presence of occupants and use of electrical devices and lighting. Model FW0 was created and its energy requirements for the climate conditions of Niš were determined. To establish the impact of using PCMs on the energy properties of the detached building, model subvariants FW1, FW2, and FW3 were created, each containing a different PCM type within its façade wall.

**Climate characteristics of the analysed location**

The considered model of a detached residential building is located in Niš, Serbia, 43°19'N and 21°54'E at the altitude of 202 m.a.s.l. According to the data from the meteorological database for Niš, the lowest mean monthly temperature was registered in January, 0.7°C, and the highest in July, 23°C. The mean monthly relative humidity is the lowest in August, 61%, and the highest in December, 80%. North-western and eastern winds are prevalent in Niš over the course of a year (Vukadinovic et al, 2020).

**Table 1.** Climatic parameters of the location for which the energy requirements of detached residential building models FW0, FW1, FW2, and FW3 were calculated

LOCATION	Latitude (°N)	Longitude (°E)	Altitude (m)	Climate type (Köppen classification from the source weather data)	ASHRAE Standard 196-2006 Climate
Niš	43.33	21.9	202	Cfa	4A

**MODEL of the detached residential building**

To examine the energy performance, a reference model based on prefabricated house (Figure 1.) of a detached residential building has been created (MODEL FW0). MODEL FW0 has an irregular floor base geometry and contains G+1 levels. The total surface area of the floor base is 203 m<sup>2</sup>, whereby the net surface area of the ground floor is 115.45 m<sup>2</sup> and the surface area of the upper floor is 87.55 m<sup>2</sup>. The floor base geometry and the 3D representation of the building are shown in Figure 1. The window-to-wall ratio of the façade is 20%.



(a)



(b)



(c)

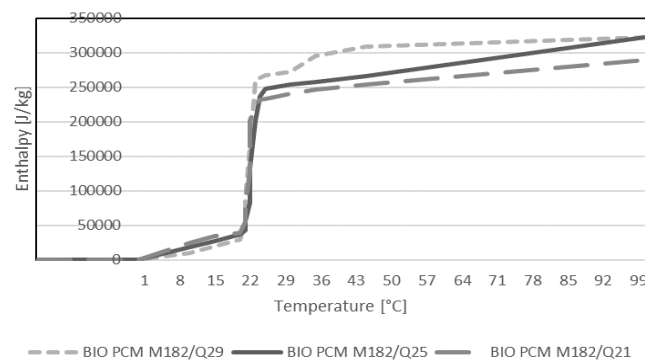
**Figure 1.** Geometry of MODEL FW0: (a) 3D representation; (b) ground floor base; (c) first floor base (Prefabricated house, 2022)

The structural elements of MODEL FW0 thermal envelope and their heat transfer coefficients are given in Table 2. The glazing type is argon-filled double PVC glazing.

The façade wall of the reference building model (MODEL FW0) is a 0.25 m thick brick wall with thermal insulation made of 0.15 m thick expanded polystyrene (U=0.2 W/m<sup>2</sup>K). For the purpose of this study, three additional models, MODEL FW1, MODEL FW2, and MODEL FW3, were created. The architectural characteristics of these models are the same as in MODEL FW0, the only difference being the façade wall structure. In MODEL FW1, the façade wall contains M182/Q21 PCM, MODEL FW2 contains M182/Q25 PCM, while MODEL F3 contains M182/Q29 PCM. The ‘M’ denotes the heat capacity of the PCM in BTU/ft<sup>2</sup>, whereas the ‘Q’ denotes the temperature of PCM phase change in °C. The selection of the PCMs was made according to the results of the research presented in (Vukadinovic et al, 2020), which determined the most favourable position of PCMs within the façade wall structure for the climate conditions of Niš. Temperature enthalpy curve for selected PCM is presented in Figure 2.

**Table 1.** Façade wall composition in MODEL FW0, MODEL FW1, MODEL FW2, and MODEL FW3

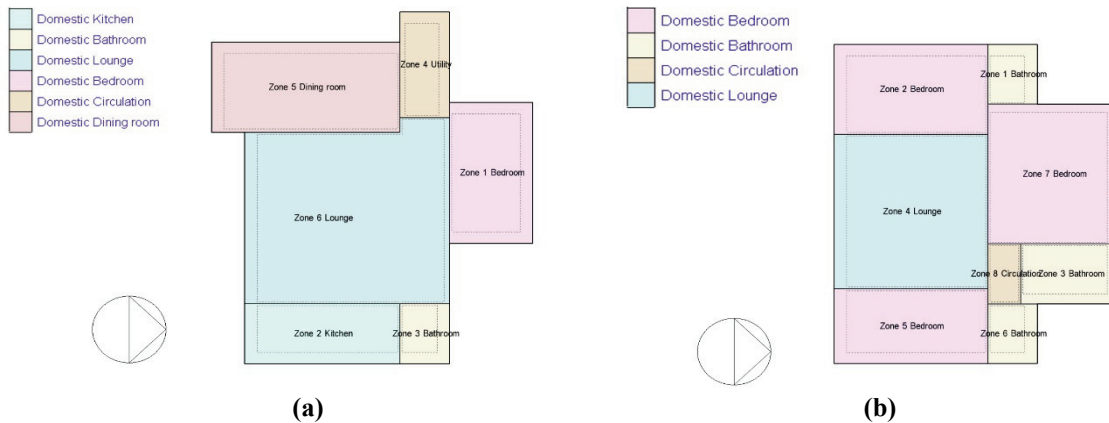
MODEL	Name (façade wall)	Properties of wall materials							Wall heat transfer coefficient U [W/m <sup>2</sup> K]
		Type of material in the partition wall	Material thickness [m]	Thermal conductivity [W/mK]	Specific heat [J/kgK]	Density [kg/m <sup>3</sup> ]	Relative water vapour diffusion coefficient		
MODEL FW0	Brick façade wall (0.25 m)	External mortar	0.02	0.72	840	1860	20	0.209	
		EPS (Expanded polystyrene)	0.15	0.035	1400	25	150		
		Brick	0.25	0.850	840	1650	50		
		Internal mortar	0.01	0.72	840	1860	20		
MODEL FW1	Brick façade wall (0.25 m) with PCM 1	External mortar	0.02	0.72	840	1860	20	0.194	
		EPS (Expanded polystyrene)	0.10	0.035	1400	25	150		
		BIO PCM M182/Q21	0.0742	0.200	1970	235	150		
		Brick	0.25	0.850	840	1650	50		
		Internal mortar	0.01	0.72	840	1860	20		
MODEL FW2	Brick façade wall (0.25 m) with PCM 2	External mortar	0.02	0.72	840	1860	20	0.194	
		EPS (Expanded polystyrene)	0.10	0.035	1400	25	150		
		BIO PCM M182/Q25	0.0742	0.200	1970	235	150		
		Brick	0.25	0.850	840	1650	50		
		Internal mortar	0.01	0.72	840	1860	20		
MODEL FW3	Brick façade wall (0.25 m) with PCM 3	External mortar	0.02	0.72	840	1860	20	0.194	
		EPS (Expanded polystyrene)	0.10	0.035	1400	25	150		
		BIO PCM M182/Q29	0.0742	0.200	1970	235	150		
		Brick	0.25	0.850	840	1650	50		
		Internal mortar	0.01	0.72	840	1860	20		



**Figure 2.** Temperature-enthalpy curve of the applied PCMs

**Table 2.** Heat transfer coefficients for the defined structural elements of MODEL thermal envelope

MODEL construction type	Structural elements of the MODEL building	Heat transfer coefficient U [W/m <sup>2</sup> K]
Ground floor base	Parquet flooring 2.2 cm, cement screed 3cm, thermal insulation 10cm, hydro insulation, lean concrete 10cm, gravel 10cm	0.28
Flat roof	Cement screed 4cm, hydro insulation, thermal insulation 15cm, sloping concrete 5cm, thermal insulation 7cm, RC slab 14cm, mortar 2cm	0.15
Windows	PVC with double glazing*, 3 mm/13 mm, argon filled (*Solar transmittance 0.55, direct solar transmittance 0.538, light transmittance 0.769)	1.50



**Figure 3.** Thermal zones of MODEL FW0 of the detached residential building: (a) ground floor (b) first floor

**Building utilisation regime**

The building was modelled with multiple thermal zones designated in terms of space utilisation regime (Figure 3).

The building’s rooms are equipped with a district heating system and a local cooling system that operates on electricity. The design temperature and occupancy are defined in relation to the thermal zone type (Table 3). Table 3 also provides the parameters used for all models in EnergyPlus™.

**Table 3.** Parameter used during simulations in EnergyPlus™ for all models of the residential building

Location parameters and space utilisation regime		
	Heating setpoint temperature [°C]	Cooling setpoint temperature [°C]
Domestic Lounge	21	25
Domestic Bedroom	18	25
Domestic Bathroom	18	25
Domestic Dining room	18	25
Domestic Circulation	18	25
<b>Ground, Surface solar reflectance 0.20</b>		
<b>Air infiltration 0.700 ac/h</b>		
<b>Lighting (W/m<sup>2</sup> – 100 lux), 5 W/m<sup>2</sup></b>		
<b>Natural ventilation, provision of minimal amount of fresh air per person (24h/day)</b>		

**RESULTS AND DISCUSSION**

Dynamic simulations were performed in EnergyPlus™ for MODEL FW0 and the three subvariants containing PCMs in their façade walls. Simulation results, which include the energy properties of the building (energy requirements for heating and cooling), are shown in Table 4.



**Table 4.** Energy requirements of building MODEL FW0, MODEL FW1, MODEL FW2, and MODEL FW3

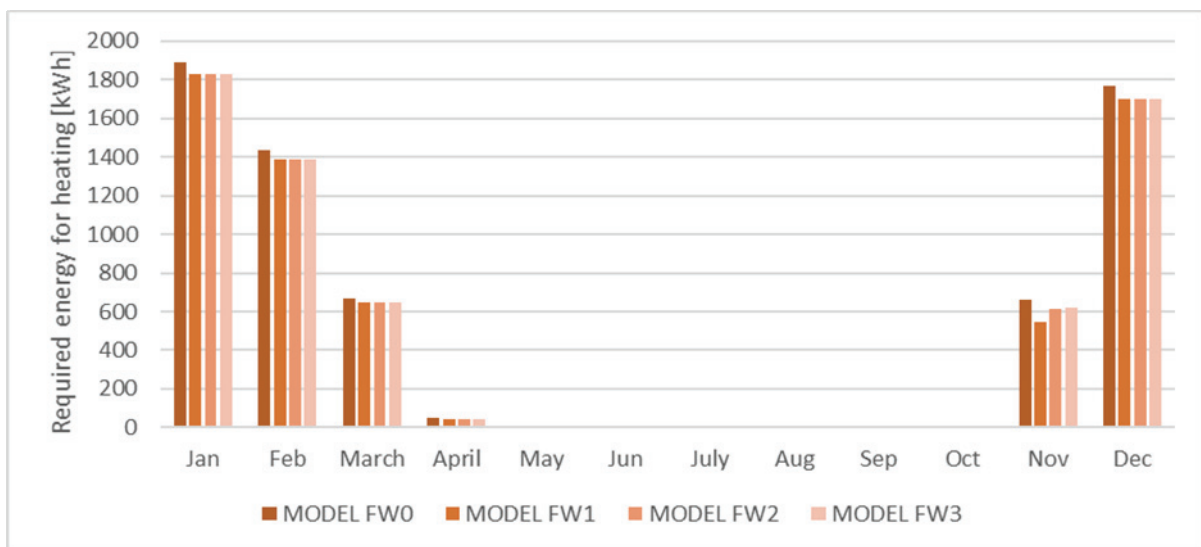
MODEL	Total heating energy required [kWh]	Total cooling energy required [kWh]	Total heating and cooling energy required [kWh]	Percentage increase (+) or decrease (-) in total heating energy required		Percentage increase (+) or decrease (-) in total cooling energy required		Percentage increase (+) or decrease (-) in total heating and cooling energy required	
				(+)	(-)	(+)	(-)	(+)	(-)
MODEL FW0	6,487.057	4,126.264	10,613.32	REF.		REF.		REF.	
MODEL FW1 (PCM 21)	6,164.087	3,975.007	10,139.09	-4.98%		-3.67%		-4.47%	
MODEL FW2 (PCM 25)	6,230.422	3,933.126	10,163.55	-3.96%		-4.68%		-4.24%	
MODEL FW3 (PCM 29)	6,236.533	3,999.911	10,236.44	-3.86%		-3.06%		-3.55%	

This research showed that MODEL FW1, containing BIO PCM M182/Q21, is the most efficient in terms of heating energy required in the climate conditions of Niš, since it requires 4.98% less energy for heating than the reference model FW0.

With regard to cooling energy requirements, MODEL FW2, which contains BIO PCM M182/Q25 is the most favourable, as its cooling energy requirements are 4.68% lower than the reference model FW0.

The total heating and cooling energy requirements of MODEL FW1 are 4.47% lower than those of the reference model.

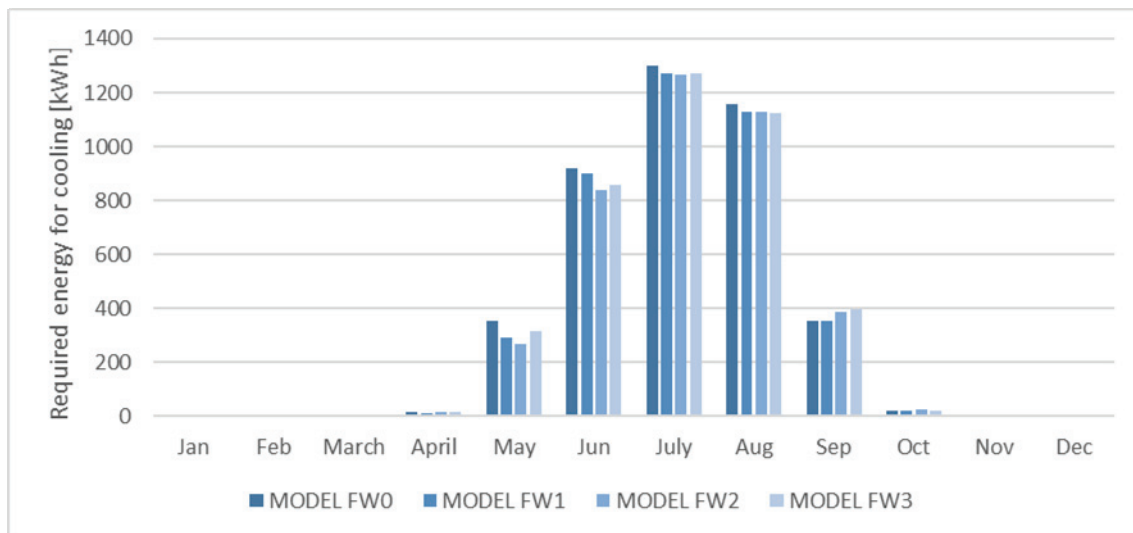
Figure 4 shows the monthly heating energy requirements for the reference model and the three subvariants (MODEL FW0, MODEL FW1, MODEL FW2, and MODEL FW3) for their location in Niš.



**Figure 4.** Total monthly heating energy requirements for MODEL FW0, MODEL FW1, MODEL FW2, and MODEL FW3 for their location in Niš

The analysis of monthly heating energy requirements of MODEL FW0 and its subvariants containing PCMs in their façade walls showed that the PCM subvariants reduced the heating energy requirements for every month.

Figure 5 shows the monthly cooling energy requirements for the reference model and the three subvariants (MODEL FW0, MODEL FW1, MODEL FW2, and MODEL FW3) for their location in Niš.



**Figure 5.** Total monthly cooling energy requirements for MODEL FW0, MODEL FW1, MODEL FW2, and MODEL FW3 for their location in Niš

The analysis of monthly cooling energy requirements of MODEL FW0 and its subvariants containing PCMs in their façade walls showed that the PCM subvariants reduced the cooling energy requirements for every month except September.

## CONCLUSION

The paper examined the energy performance of models of a detached residential building in Niš, Serbia, with a 0.25 m thick brick façade wall, with and without phase-change materials (PCMs) inside the wall. The energy properties of the models were considered in terms of PCM type (PCM 1: M182/Q21; PCM 2: M182/Q25; and PCM 3: M182/Q29) applied over the entire façade surface area. The results of the analysis led to the conclusion that the most favourable PCM type can be determined based on the indoor space utilisation regime and the temperature of PCM change from solid to liquid phase. With regard to heating, PCM M182/Q21 was the most favourable material, which corresponds to the winter indoor temperature regime. The required heating energy of the building model containing this PCM was 4.98% lower than the heating energy required for the reference model, which contains no PCM.

In terms of cooling energy requirements, PCM M182/Q25 was the most favourable, which correlates with the cooling setpoint temperature. The required cooling energy of the building model containing this PCM was 4.68% lower than the cooling energy required for the reference model.

The total heating energy requirements for the model containing PCM M182/Q21 were 4.47% lower than the reference model. It may be concluded that the use of PCMs in the façade wall structure improves the energy performance of a detached residential building in the climate conditions of Niš. To obtain a clearer picture of the effect of PCMs on energy performance, it is

necessary to investigate the energy performance of buildings in different climate zones.

## ACKNOWLEDGMENT

The paper is part of the research funded by the Ministry of Education, Science and Technology of the Republic of Serbia according to the Agreement on the implementation and financing of the scientific research work of NIO in the year 2022, Registration number of the Agreement 451-03-68/2022-14/ 200148.

## REFERENCES

- Cai, R. *et al.* (2021) 'Review on optimization of phase change parameters in phase change material building envelopes', *Journal of Building Engineering*, 35(August 2020), p. 101979. doi: 10.1016/j.job.2020.101979.
- Duraković, B. (2020) *Phase change materials for building envelope*, *Green Energy and Technology*. doi: 10.1007/978-3-030-38335-0\_2.
- Energy, U. S. Department of Energy (2019) *Engineering Reference, EnergyPlus™ Version 9.1.0 Documentation*.
- Prefabricated house Lena, (2022) <https://www.eko-kuca.com/spratne-kuce/montazna-kuca-lena/>
- Suresh, C., Kumar Hotta, T. and Saha, S. K. (2022) 'Phase change material incorporation techniques in building envelopes for enhancing the building thermal Comfort-A review', *Energy and Buildings*, 268, p. 112225. doi: 10.1016/j.enbuild.2022.112225.
- Vukadinović, A. Radosavljević, J. Đorđević, A. (2020). *Energy performance impact of using phase-change materials in thermal storage walls of detached residential buildings with a sunspace*, *Solar Energy*,

Volume 206, 2020, Pages 228-244, ISSN 0038-092X,  
<https://doi.org/10.1016/j.solener.2020.06.008>.

Wang, X. *et al.* (2022) 'A critical review on phase change materials (PCM) for sustainable and energy efficient building: Design, characteristic, performance and application', *Energy and Buildings*, 260, p. 111923. doi: 10.1016/j.enbuild.2022.111923

## BIOGRAPHY of the first author

**Ana Vukadinović** was born in Niš, Serbia, in 1979.

She graduated from the Faculty of Civil Engineering and Architecture, University of Niš. She completed her PhD studies at the Faculty of Occupational Safety in Niš.



Ana Vukadinović has published 19 papers in international and national journals, whereof 5 papers are listed in the SCI index of Clarivate Analytics, 34 papers at international scientific conferences, and 2 papers at national scientific conferences. She participated in the project funded by the Ministry of Science and Technological Development of the Republic of Serbia. She is a member of the International Solar Energy Society (ISES).

Her research interests comprise Bioclimatic architecture, Green building, Energy efficiency in buildings, Building simulation, Building energy performance, Urban planning, Thermal comfort, Pollutant emissions, and Environmental engineering.



MILAN PROTIĆ<sup>1</sup>  
NIKOLA MIŠIĆ<sup>2</sup>  
MIOMIR RAOS<sup>3</sup>  
ANA VUKADINVIĆ<sup>4</sup>

<sup>1,2,3,4</sup> University of Niš,  
Faculty of Occupational Safety

<sup>1</sup>milan.protic@znrfak.ni.ac.rs

<sup>2</sup>nikola.misic@znrfak.ni.ac.rs

<sup>3</sup>miomir.raos@znrfak.ni.ac.rs

<sup>4</sup>ana.vukadinovic@znrfak.ni.ac.rs

## APPLICATION OF NEURAL NETWORKS WITH BAYESIAN REGULARIZATION FOR PREDICTING CONSUMERS' HEAT LOAD IN DISTRICT HEATING SYSTEMS

**Abstract:** District heating systems (DHS) are now considered as one of the best options for the provision of heat in urban environments. However, most DHS in Serbia operate economically and environmentally inefficiently. Many options are available for the optimization of these systems. One of the possibilities is an improvement of existing inefficient control strategies in DHS. Predictive models of consumers' heat load could play important role in these novel strategies. In this paper procedures for developing and testing predictive models of consumers' heat load based on neural networks with direct signal propagation and Bayesian regularization were described. Data used for model building were acquired from two district systems in Serbia. Obtained results, with satisfactory predictive performances, indicate that the proposed methodology can be used for model building purposes and deployed for improvement of present inefficient control strategies.

**Key words:** District heating systems, control strategies, heat load prediction, neural networks, Bayesian regularization.

### INTRODUCTION

District heating systems (DHS), if properly managed, can be regarded as the most efficient option for heating in densely populated urban areas (Frederiksen and Werner, 2013). Moreover, these systems have great potential to reduce emissions and decarbonize the heating sector. In 2013 DH global market share was 12% of the total heat production (Connolly *et al.*, 2013). The figures were much higher in some countries. In Sweden, for example, market share in 2014 was a remarkable 89% (Werner, 2017). DHS uptake was recently noticed even in countries where DH was not a preferable option for heat provision (e.g. UK), meaning that the DHS market share will most probably arise in the years to come. In EU 28 only, approximately 750 TWh of heat energy was produced in DHS in 2012. In Serbia, heat production in 56 DH systems in 2017 was impressive 7000 GWh, with natural gas as the main fuel (73%) (*Izveštaj o radu sistema daljinskog grejanja u Republici Srbiji za 2018. godinu*, 2019). Just the fuel costs for these systems were at the level of 200 mil eur meaning that DHS are utility systems of special importance.

While DH systems are based on mature and proven technology, tremendous opportunities for improvement of their operation exist both on national and wider, global scale. This is particularly important taking into account the scale of operating costs (most notably for fuel) in these systems. Even the slight improvements can produce significant savings in money and emission

of pollutants. The main strategic improvement in DH systems could be achieved through expanding present infrastructure for the utilization of waste heat (particularly from combined heat and power (CHP) plants). While profitable on the longer-term, these interventions require significant capital investments. However, the huge unlocked potential for improvement lies in the reengineering of present obsolete and non-optimal short and long term operation strategies of DHS. Implementation of new, intelligent control schemes based on recent advances in the machine learning field could be a game-changer in a short term, providing considerable savings with minute interventions on existing infrastructure and minimal allocation of financial resources. Immediate results could be achieved through efficiency-boosting, reducing operating costs, mitigating the environmental impacts of DHS, and bringing social benefits (by lowering heat provision costs for customers).

The main aim of present work is in examining performances of predictive models based on one special class of machine learning methods, namely Neural Networks with Bayesian Regularization. Data acquired from substations from two DHS in Serbia were used for model building and testing.



## MATERIALS AND METHODS

### Data acquisition for model building

#### Niš District heating system

The district heating system (DHS) in Niš was put into operation in the 1980s with the construction of two district heating plants – “Krivi vir” and “Jug”. Today, the heating energy from the Niš heating plants distribute heat across 1,581,053 m<sup>2</sup> of residential area and 377,144 m<sup>2</sup> of commercial area. The length of the district heating network is 69 km with 1,114 substations connected to the main distribution network. The system utilises natural gas (90%) and mazut heavy oil (10%) as the energy-generating products. The total installed capacity of all heat sources in the Niš DHS is 254 MW. Heat energy is generated in three heating plants and eleven additional boiler facilities.

The data for the Niš DHS were acquired during the 2009/2010 heating season in one of the heating substations. Via the distribution network, the substation is connected to the “Krivi vir” plant, which has the total installed capacity of 128 MW. The substation installation is shown in Figure 1.



**Figure 1.** The appearance of the substation installation at 3 Romanijska Street, Niš

Consumers are directly connected to the distribution network (primary supply). Hydraulic separation is performed using the Schmidt SIGMA X13-NCL heat exchanger, with an installed power of 650 kW.

#### Novi Sad District heating system

The Novi Sad DHS, with an installed power of 877.3 MW, is the second largest DHS in Serbia, after the Belgrade DHS. The Novi Sad DHS supplies heat to 101,948 consumers, 93,971 of which are households and 7,977 commercial consumers. Sanitary hot water is supplied to 32,499 consumers. The total length of the district heating distribution network is 219.8 km, covering 3,832 connected heating substations.

During the 2010/2011 heating season, data had been acquired from six substations of the Novi Sad DHS, but subsequent analysis revealed that the data from only one substation could be used for further analysis.

### Prediction method - Bayesian approach to regularisation

The goal of training networks is to determine the optimal values of synaptic weights. Those values are usually obtained using the minimisation of criterion function  $E(\mathbf{w})$ , which is most often defined as the  $L_2$  norm of desired and actual outputs of a neural network:

$$E(\mathbf{w}) = E_D(\mathbf{w}) = \frac{1}{2} \sum_{i=1}^n (y_i - O(\mathbf{x}_i, \mathbf{w}))^2, \quad (1)$$

where  $y_i$  refers to output data from the training set and  $O(\mathbf{x}_i, \mathbf{w})$  refers to neural network outputs for the training set of data. Since this criterion is related to the data, it is usually denoted as  $E_D(\mathbf{w})$ . An additional requirement in neural network training is to limit the complexity of a neural network. The complexity refers to the number of network parameters (synaptic weights). If the number of parameters is large, after the optimal values have been determined, it is almost certain that a network prone to overfitting will be the result. Therefore, it is crucial to limit the number of network parameters. One way to do that is to perform network pruning, also known as optimal brain surgery. In this method, specific parameters are assigned the value of zero, which simplifies the network structure. The full details of this method are available in (Hassibi *et al.*, 1994). However, if the inputs in a neural network comprise those that are collinear, which is a frequent occurrence, it is not recommended to prune more than one parameter (Ripley, 1996), which is contrary to the initial goal of reducing structural complexity.

An alternative way to create an optimal neural network structure is to introduce an additional regularisation member that penalizes high-weight values. The limitation of weight values ensures that the outputs are smooth. This is important if one accepts the assumption that the hidden function, estimated through modeling, is differentiable to a certain extent. Additionally, as the structural complexity decreases, the generalization properties of the neural network increase. One of the options for regularisation is to introduce a member for weight decay (Abu-Mostafa, 1990):

$$E_w(\mathbf{w}) = \frac{1}{2} \sum_{i=1}^n w_i^2. \quad (2)$$

If the additional regularisation member is integrated into the expression for the criterion function and if coefficients  $\alpha$  and  $\beta$ , which serve to weight the influence of members, the following expression is obtained:

$$E(\mathbf{w}) = \beta E_D(\mathbf{w}) + \alpha E_w(\mathbf{w}). \quad (3)$$

Optimal weight values are obtained using the minimisation of the criterion function  $E(\mathbf{w})$  through optimisation, most often using gradient descent. However, there is a problem concerning the determination of optimal values for parameters  $\alpha$  and

$\beta$ . The classic approach involves determining the unknown parameters using the search method, which is based on cross-validation of a large number of combinations with different parameter values. Such an approach is arbitrary and computation-demanding. A potential solution may be sought within the Bayesian context.

In the Bayesian context, synaptic weights are considered as random variables. According to the Bayes' theorem, posterior density of synaptic weights, after the data from the system have arrived, can be expressed as follows:

$$P(\mathbf{w}|D, \alpha, \beta) = \frac{P(D|\mathbf{w}, \beta)P(\mathbf{w}|\alpha)}{P(D|\alpha, \beta)}, \quad (4)$$

where  $P(D|\mathbf{w}, \beta)$  is the credibility of weights  $\mathbf{w}$  for given data  $D$ ,  $P(\mathbf{w}|\alpha)$  is the a priori density of weights, which in fact incorporates weight information before data arrival, while  $P(D|\alpha, \beta)$  is the normalisation constant, ensuring that

$$\int P(\mathbf{w}|D, \alpha, \beta) d\mathbf{w} = 1, \quad (5)$$

which follows from the basic axioms of probability. The assumption is that the neural network architecture is adopted a priori, i.e. before weight determination. If that is not the case, it is necessary to incorporate the influence of architecture, or of network shape, into the expressions for posterior density, credibility, and normalisation constant.

There are two ways to calculate posterior weight density. The first is the Laplace method, which involves determining the maximum a posteriori estimate (MAP) (MacKay, 1992a). This method is the Bayesian equivalent of the maximum credibility method. The second is the Markov chain Monte Carlo (MCMC) method (Neal, 1996). The present paper considers only the former.

Focusing once again on the posterior weight density expression  $P(\mathbf{w}|D, \alpha, \beta)$ , if one assumes that a priori density and credibility are defined using Gaussian distribution, the expression may be written as

$$P(D|\mathbf{w}, \beta) = \frac{1}{K_D(\beta)} e^{-\beta E_D(\mathbf{w})}, \quad (6)$$

and

$$P(\mathbf{w}|\alpha) = \frac{1}{K_W(\alpha)} e^{-\alpha E_w(\mathbf{w})}, \quad (7)$$

where  $K_D(\beta) = \left(\frac{\pi}{\beta}\right)^{\frac{n}{2}}$  and  $K_W(\alpha) = \left(\frac{\pi}{\alpha}\right)^{\frac{m}{2}}$ , while

indices  $n$  and  $m$  are the total member of training pairs and the total number of synaptic weights, respectively.

After substituting equation (4) with the expressions for a priori density and credibility, the final form of a posteriori density is obtained:

$$P(\mathbf{w}|D, \alpha, \beta) = \frac{1}{K_E(\alpha, \beta)} e^{-E(\mathbf{w})}, \quad (8)$$

where  $K_E(\alpha, \beta)$  is the normalisation factor unifying the normalisation factors from the expressions for  $P(D|\mathbf{w}, \beta)$ ,  $P(\mathbf{w}|D, \alpha, \beta)$ , and  $P(\mathbf{w}|\alpha)$ .

To determine the posterior density, it is necessary to first determine the optimal values of parameters  $\alpha$  and  $\beta$ . If these parameters are also considered within the Bayesian context, their optimal values can be obtained by maximising the a posteriori density  $P(\alpha, \beta|D)$ .

Using the Bayes' theorem, this density may be represented as follows:

$$P(\alpha, \beta|D) = \frac{P(D|\alpha, \beta)P(\alpha, \beta)}{P(D)}. \quad (9)$$

The problem of maximising a posteriori density  $P(\alpha, \beta|D)$  in case of uniform distribution  $P(\alpha, \beta)$  is equivalent to the problem of maximising credibility  $P(D|\alpha, \beta)$  (Foresee and Hagan, 1997). On the other hand, credibility  $P(D|\alpha, \beta)$  represents the normalisation constant in the equation for a posteriori density of synaptic weights (8). The following expression follows from the equation for a posteriori weight density:

$$P(D|\alpha, \beta) = \frac{P(D|\mathbf{w}, \beta)P(\mathbf{w}|\alpha)}{P(\mathbf{w}|D, \alpha, \beta)}. \quad (10)$$

After elementary transformations, the following equation is obtained:

$$P(D|\alpha, \beta) = \frac{K_E(\alpha, \beta)}{K_D(\beta)K_W(\alpha)}. \quad (11)$$

Normalisation factors  $K_D(\beta)$ ,  $K_W(\alpha)$  and  $K_E(\alpha, \beta)$  have already been defined above. In the top expression,  $K_E(\alpha, \beta)$  is unknown. The value of this factor can be determined by developing the criterion function into a Taylor series in the vicinity of point  $\mathbf{w}^*$ , which represents a mode of posterior density. In this point, gradient equals zero, so the criterion function may be approximated as follows:

$$E(\mathbf{w}) \approx E(\mathbf{w}^*) + \frac{1}{2}(\mathbf{w} - \mathbf{w}^*)^T \mathbf{H}^* (\mathbf{w} - \mathbf{w}^*), \quad (12)$$

where  $\mathbf{H}^* = \frac{\partial^2 E(\mathbf{w})}{E(\mathbf{w})^2}$  is the Hessian matrix calculated in point  $\mathbf{w} = \mathbf{w}^*$ . After the approximation, the normalisation constant  $K_E(\alpha, \beta)$  becomes

$$K_E(\alpha, \beta) = (2\pi)^{\frac{m}{2}} |\mathbf{H}^*|^{-\frac{1}{2}} e^{-E(\mathbf{w}^*)}. \quad (13)$$

It is now possible to calculate the credibility  $P(D|\alpha, \beta)$ . Maximisation is easier to perform after the following logarithmisation:

$$\log P(D|\alpha, \beta) = \frac{n}{2} \log(\beta) + \frac{m}{2} \log(\alpha) - \frac{m}{2} \log(2\pi) - \beta E_D(\mathbf{w}^*) - \alpha E_w(\mathbf{w}^*) - \frac{1}{2} \log |\mathbf{H}^*| \quad (14)$$

The values of the unknown coefficients are obtained in two steps. In the first step,  $\alpha$  is fixed, after which the top expression is differentiated with respect to  $\beta$ , equated to zero, and solved for the maximum. In the second step,  $\beta$  is fixed, the expression differentiated with respect to  $\alpha$ , equated to zero, and then solved for the maximum. The procedure is described in full detail in (MacKay, 1992b). Ultimately, the optimal values of parameters and are obtained, in the following form:

$$\alpha^* = \frac{\gamma}{2E_w(\mathbf{w}^*)} \quad (15)$$

$$\beta^* = \frac{n-\gamma}{2E_D(\mathbf{w}^*)}$$

where  $\gamma = m - 2\alpha^* \text{tr}ag(\mathbf{H}^*)^{-1}$ . Parameter  $\gamma$  is called the effective number of parameters.

Bayesian regularisation shown above involves Hessian matrix calculation. It has been stated previously that the Levenberg-Marquardt algorithm is one of the most efficient algorithms for determining the optimal values of synaptic weights assuming that the criterion function is given as the sum of squared estimate of errors. Additionally, this method implicitly contains the Gauss-Newton algorithm for Hessian optimisation, which can be utilised to optimise the regularisation.

The steps for Bayesian optimisation of regularisation parameters using the Gauss-Newton approximation of the Hessian matrix are provided below (Foresee and Hagan, 1997):

1. Adoption of initial values of parameters  $\alpha$  and  $\beta$  and initialisation of the values of synaptic weights. In weight initialisation, the values may be adopted as random numbers, whereas (Foresee and Hagan, 1997) propose the use of the Nguyen-Widrow initialisation method (Nguyen and Widrow, 1990);
2. Execution of the first step in the Levenberg-Marquardt algorithm, whereby  $E(\mathbf{w}) = \beta E_D(\mathbf{w}) + \alpha E_w(\mathbf{w})$  is taken as the criterion function;
3. Calculation of  $\gamma$ , where the Hessian matrix value is obtained approximately using the expression  $\mathbf{w}_{k+1} = \mathbf{w}_k - (\mathbf{J}^T \mathbf{J} + \lambda_k \mathbf{I})^{-1} \mathbf{J}^T \varepsilon(\mathbf{w})$  from the Levenberg-Marquardt algorithm, whereby the initial approximation  $\mathbf{J}^T \mathbf{J} + \lambda_k \mathbf{I}$  takes the form  $\beta \mathbf{J}^T \mathbf{J} + \alpha \mathbf{I}$  in the case of regularisation;

4. After  $\gamma$  has been determined, new values of parameters  $\alpha$  and  $\beta$  are calculated from the equations

$$\alpha = \frac{\gamma}{2E_w(\mathbf{w})}$$

$$\beta = \frac{n-\gamma}{2E_D(\mathbf{w})}$$

5. Repetition of procedures in steps 2-4 until convergence has been achieved.

## RESULTS AND DISCUSSION

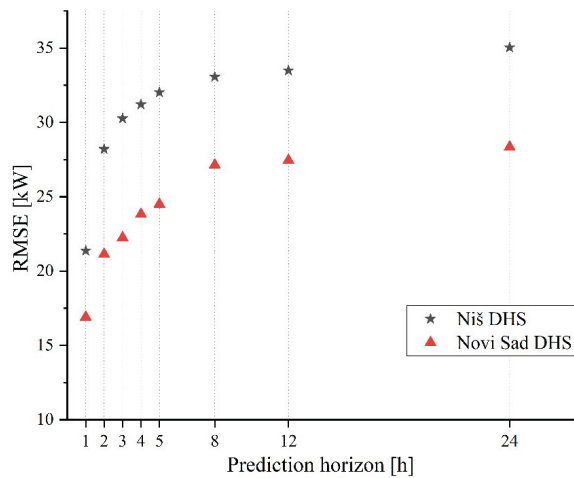
First of all, it was necessary to define prediction horizons and prediction intervals, which then required predictive models to be developed. Prediction horizons are divided into short-term, for 1, 2, 3, 4, and 5 hours ahead and long-term horizons, for 8, 12, and 24 hours ahead. The basic idea is to use the short-term models to manage the DHS, while the long-term prediction horizon models are intended for operation planning of the DHS. Different short-term prediction horizons were needed in order to adequately handle the consumers located at different distances from the heat source. Hot water reaches the consumers from the source at average speed, so different distances required models with different prediction horizons. It has been estimated that 5h-ahead horizons are sufficient for heat load predictions even for the most remote consumers in the DHSs considered in this paper. On the other hand, predictive models for longer horizons were developed for the purpose of DHS operation planning.

As stated, a separate model was developed for each prediction horizon and tested using the available data. The models were developed using a network with two hidden neurons. The predictive models were created first, with heat load inputs lagging from 1 to 48 hours. Prediction results are shown in Table 1.

**Table 1.** Predictive performance of the BRNN heat load model for the Niš and Novi Sad DHSs; input variables – heat load with lags from 1h to 48h

Prediction horizon	Predictive performance: BRNN method			
	Data source – Niš DHS		Data source – Novi Sad DHS	
	RMSE [kW] Training set	RMSE [kW] Test set	RMSE [kW] Training set	RMSE [kW] Test set
1h ahead	23.821	21.375	18.194	16.652
2h ahead	35.075	28.195	25.123	20.217
3h ahead	36.965	30.265	28.777	21.921
4h ahead	39.631	31.207	31.685	23.131
5h ahead	40.706	32.021	34.111	24.539
8h ahead	41.616	33.063	38.228	26.696
12h ahead	41.747	33.488	40.711	26.791
24h ahead	44.039	35.037	46.021	28.414

Additionally, the results are presented graphically in Figure 2.



**Figure 2.** Comparison of prediction results for the Niš and Novi Sad DHS; input variables – heat load with lags from 1h to 48h

Performances of predictive models were assessed using Root Mean Square Error (RMSE):

$$RMSE = \sqrt{\frac{\sum_{i=1}^n (P_i - O_i)^2}{n}} \quad (16)$$

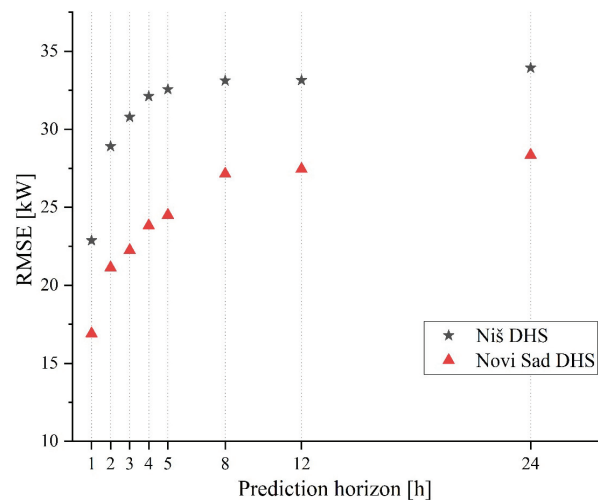
where  $P_i$  and  $O_i$  are values obtained from prediction models and observations, respectively.

The next step involved the testing of predictive performance in models with previous heat load values from 1h to 24h used as inputs. Prediction results are shown in Table 2.

**Table 2.** Predictive performance of the BRNN heat load model for the Niš and Novi Sad DHSs; input variables – heat load with lags from 1 to 24h

Prediction horizon	Predictive performance: BRNN method			
	Data source – Niš DHS		Data source – Novi Sad DHS	
	RMSE [kW] Training set	RMSE [kW] Test set	RMSE [kW] Training set	RMSE [kW] Test set
1h ahead	24.087	22.872	19.631	16.908
2h ahead	33.002	28.908	26.292	21.132
3h ahead	36.436	30.785	29.572	22.241
4h ahead	38.246	32.112	31.860	23.821
5h ahead	38.193	32.560	33.854	24.502
8h ahead	39.366	33.119	37.007	27.137
12h ahead	40.635	33.138	38.719	27.448
24h ahead	40.860	33.938	45.423	28.345

Additionally, the results are presented graphically in Figure 3.

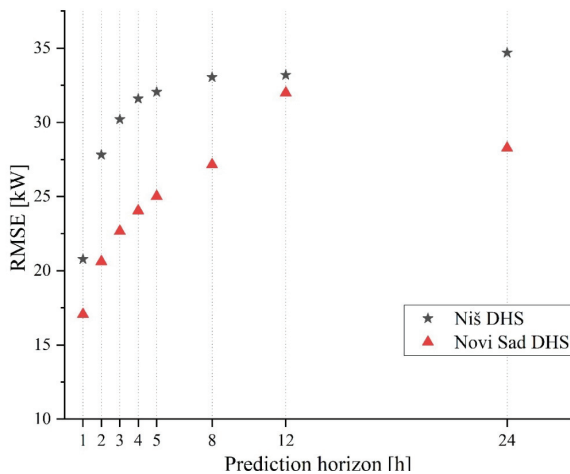


**Figure 3.** Comparison of prediction results for the Niš and Novi Sad DHS; input variables – heat load with lags from 1h to 24h

After the models whose input variables lagged from 1h to 48h and from 1h to 24h backward, we created the models whose input variable were determined based on the plots of the autocorrelation and partial autocorrelation functions (ACF) (Protić *et al.*, 2021). The obtained prediction results are shown in Table 3.

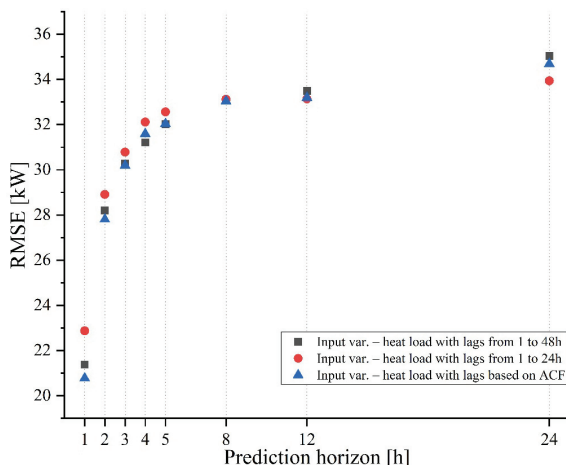
**Table 3.** BRNN predictive performance for the Niš and Novi Sad DHSs; input variables – heat load with lags based on the partial autocorrelation function

Prediction horizon	Predictive performance: BRNN method			
	Data source – Niš DHS		Data source – Novi Sad DHS	
	RMSE [kW] Training set	RMSE [kW] Test set	RMSE [kW] Training set	RMSE [kW] Test set
1h ahead	22.483	20.777	18.022	17.058
2h ahead	32.362	27.811	24.286	20.618
3h ahead	36.041	30.195	28.107	22.663
4h ahead	38.074	31.595	30.732	24.043
5h ahead	39.409	32.040	32.35	25.014
8h ahead	40.539	33.040	36.029	27.150
12h ahead	39.966	33.189	42.805	31.990
24h ahead	41.541	34.693	45.078	28.265

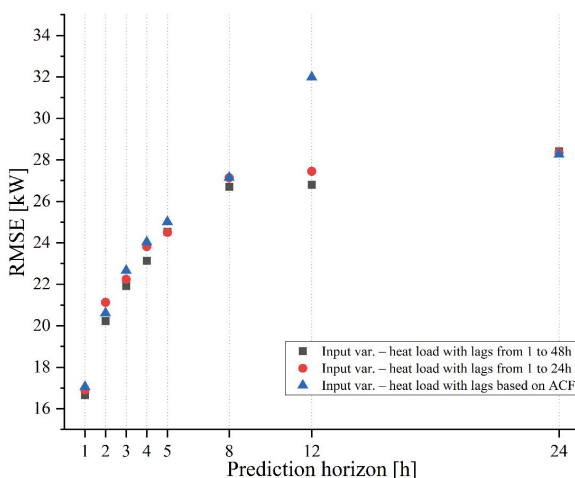


**Figure 4.** Comparison of prediction results for the Niš and Novi Sad DHS; input variables – heat load with lags based on the partial autocorrelation function

In order to provide better overview of predictive performance of different models, two following graphics were created:



**Figure 5.** Comparison of prediction results for the Niš DHS; input variables – heat load with different combination of lags



**Figure 6.** Comparison of prediction results for the Novi Sad DHS; input variables – heat load with different combination of lags

Number of conclusions can be derived from following figures. Obtained predictive results in the case of Novi Sad DHS are much better when compared to results from Nis DHS. As was expected, predictive performances deteriorate with increased predictive horizon. However, differences for higher predictive horizons (> 8h ahead) are fairly subtle. This is the case for data sets from both DHS. Significant deviation was noticed only for the model for Novi Sad DHS for predictive model with input variables with lags based on ACF and for prediction horizon of 12 h ahead. Most probably, obtained value is outlier. Interestingly, predictive performances are quite insensitive to number and type of models' input variables, while computation complexity markedly differs. For Nis DHS, for most predictive horizons, best predictive results were obtained with input variables based on ACF as opposed to Novi Sad DHS where best predictive performances were achieved with model with previous heat load values from 1h to 24h used as inputs.

### CONCLUSION

In this work predictive models of heat load of consumers in two DHS in Serbia based on Neural Networks with Bayesian Regularization were developed. Data used for model building and testing were acquired from two substations from Nis and Novi Sad DHS using custom made data acquisition systems. Independent data sets were used for building and testing predictive models. RMSE, as common metric for assessing regression models, was used for comparing predictive performances of developed models. From obtained results following conclusions can be derived:

- Predictive models based on Neural Networks with Bayesian Regularization provide satisfactory predictive results;
- Obtained results highly depend on quality of available data sets for model building/testing;
- Previous values of heat load were used as inputs and it seems that number of inputs (lags) used is of minor significance;
- Predictive performances of models for both DHS deteriorate with incising predictive horizon while the effect is most pronounced for shorter horizons (from 1 to 8h ahead);
- Predictive performances for longer horizons (8 to 24h ahead) were very similar;
- Performances of models could be probably improved with inclusion of exogenous inputs (e.g. ambient temperature with and without lags).



## REFERENCES

Abu-Mostafa, Y. S. (1990) 'Learning from hints in neural networks', *Journal of Complexity*, 6(2), pp. 192–198. doi: 10.1016/0885-064X(90)90006-Y.

Connolly, D. et al. (2013) *Heat Roadmap Europe 2: Second pre-study for the EU27*. Department of Development and Planning, Aalborg University.

Foresee, F. D. and Hagan, M. T. (1997) 'Gauss-Newton approximation to Bayesian learning', in *Proceedings of International Conference on Neural Networks (ICNN'97)*, pp. 1930–1935. doi: 10.1109/ICNN.1997.614194.

Frederiksen, S. and Werner, S. (2013) *District Heating and Cooling*. Studentlitteratur AB.

Hassibi, B. et al. (1994) 'Optimal brain surgery: expansions and performance comparisons', *Advances in Neural Information Processing Systems*, 6, pp. 263–270.

*Izveštaj o radu sistema daljinskog grejanja u Republici Srbiji za 2018. godinu* (2019).

MacKay, D. J. C. (1992a) 'A Practical Bayesian Framework for Backpropagation Networks', *Neural Computation*, 4(3), pp. 448–472. doi: 10.1162/neco.1992.4.3.448.

MacKay, D. J. C. (1992b) 'Bayesian Interpolation', *Neural Computation*, 4(3), pp. 415–447. doi: 10.1162/neco.1992.4.3.415.

Neal, R. (1996) 'Bayesian Learning for Neural Networks', in *Lecture Notes in Statistics*. New York: Springer, p. 118.

Nguyen, D. and Widrow, B. (1990) 'Improving the learning speed of 2-layer neural networks by choosing initial values of the adaptive weights', in *1990 IJCNN International Joint Conference on Neural Networks*, pp. 21–26. doi: 10.1109/IJCNN.1990.137819.

*NST*. Available at: <http://www.nstoplana.rs/>.

Protić, M. et al. (2021) 'Development of heat load predictive models in district heating systems using the boosting method', in *Industrial Engineering and Environmental Protection (IIZS 2021)*. University of Novi Sad, Technical faculty "Mihajlo Pupin", pp. 368–374.

Ripley, B. D. (1996) *Pattern Recognition and Neural Networks*. Cambridge University Press. doi: 10.1017/CBO9780511812651.

Werner, S. (2017) 'District heating and cooling in Sweden', *Energy*, 126, pp. 419–429. doi: <https://doi.org/10.1016/j.energy.2017.03.052>.

## ACKNOWLEDGEMENTS

This work was financially supported by the Ministry of Education, Science and Technological Development of the Republic of Serbia, [Grant No. 451-03-68/2022-14/200148].

## BIOGRAPHY of the first author

**Milan Protić** was born in Niš, Serbia, in 1979. He received a diploma in mechanical engineering and a Ph.D. degree from the University of Niš, Faculty of Occupational Safety in Niš.



His main areas of research include renewable energy sources, district heating systems, combustion, and fire research. He works as an associate professor at the Faculty of Occupational Safety in Niš, University of Niš.



ANA STOJANOVIĆ<sup>1</sup>  
DEJAN VASOVIĆ<sup>2</sup>

<sup>1,2</sup> University of Niš,  
Faculty of Occupational Safety  
<sup>1</sup>ana.stojanovic@znrfak.ni.ac.rs  
<sup>2</sup>dejan.vasovic@znrfak.ni.ac.rs

## BENCHMARKING TECHNIQUE FOR EVALUATING THE PERFORMANCE OF PUBLIC UTILITY COMPANIES

**Abstract:** *Public utility companies (PUCs) play a key role in achieving sustainable development goals in urban areas. In order for such companies to meet the growing demands and expectations of consumers, they need to analyse their performance over time, and benchmarking is a suitable technique for that purpose. This paper presents a theoretical analysis of benchmarking and an analysis of its application to the evaluation of PUCs' business performance. Special emphasis is placed on water and sanitation companies, considering that their operations are crucial for the exercise of one of the basic human rights – continuous delivery of hygienically safe drinking water. Finally, the paper presents the IBNET database and the most frequently used key performance indicators in the field, including the way they are selected.*

**Key words:** public utility companies, benchmarking, water and sanitation companies, IBNET, KPIs

### INTRODUCTION

Public utilities refer to the provision of public utility services relevant for meeting the living demands of natural and legal persons, whereby the authorised local self-government unit is mandated to facilitate the provision of proper quality, scope, availability, and continuity of such services and to monitor their provision (Zakon o komunalnim delatnostima, 2018). For this purpose, the authorized local self-government unit will establish public utility companies (PUCs). The relationship of local authorities and the state toward the subjects of local communities, i.e. the citizens, is most directly reflected in the provision of public utility services.

Operation of PUCs is an essential sector of global economy. As the demand for a higher quality of services increases, their financing becomes more limited. Consequently, PUCs worldwide are expeditiously seeking ways to improve their performance and provide better service at the lowest possible price. Comparisons against similar PUCs in other parts of the country or region or against international standards of good practice may shed some light on how well a PUC operates, what areas need improvement, and how to plan further activities.

Such comparisons can be made using the benchmarking technique, which is actually a systematic and continuous process of measuring performance and comparing business processes of a specific subject against the business processes of leaders in the field, all for the purpose of obtaining information that would be useful later, when actions are taken to improve performance. The review of business practices has

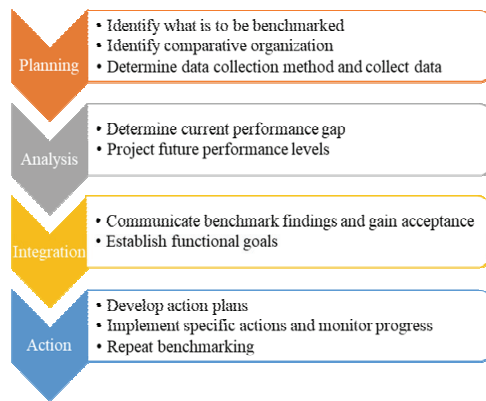
intensified over the previous years, while the need for transparent and standardised information against which PUC performance would be compared became even more prominent. This in turn led to a greater need to measure results and responsibilities. As a result, the use of benchmarking increased and its value became widely recognized (Danilenko & Berg, 2011).

### BENCHMARKING TECHNIQUE

The benchmarking technique is a business concept applied in strategic planning, marketing, restructuring, financial management, and the practice of "learning from the best" (Marković et al., 2011). The technique emerged in the private sector in the 1980s, when the American company *Xerox* decided to solidify its competitive advantage by assessing its performance against its competitors in the market (Cabrera, 2008).

Benchmarking is defined as "a systematic process of searching for best practices, innovative ideas, and highly effective operating procedures that lead to superior performance and then adapting these practices, ideas, and procedures to improve the performance of one's own organisation" (Parena & Smeets, 2001).

The benchmarking process usually involves four phases: planning, analysis, integration, and action. The four phases are subdivided into a total of ten steps (Figure 1), characterising the procedure in a more meaningful way (Freiling & Huth, 2002).



**Figure 1.** The process of benchmarking best practice, modified according to Camp, 1989

The planning phase comprises three steps, the first identifying what is to be benchmarked and the second identifying the organisation to be compared. A potential partner in the benchmarking project needs to be introduced to the benefits of cooperation, which will create additional incentives. The third step involves determining the data collection method and collecting the data. It is clear that the first two steps are fundamental, because all benchmarking phases depend on adequate selection. The second, analysis, phase describes the use of all data sources and comprises two steps, the first determining the current performance gap (step 4) and the second projecting future performance levels (step 5). The integration phase involves (internal) communication of the benchmark findings and the acceptance process (step 6) and the establishment of functional goals (step 7). The fourth phase pertains to action in the benchmarking process and involves the development of action plans (step 8), implementation of specific actions and monitoring of progress (step 9), and repetition of the benchmarking (step 10). Within this context, it is necessary to identify a sustainable manner of implementation.

The primary objectives of benchmarking are the following (Danilenko & Berg, 2011):

1. To provide a set of Key Performance Indicators (KPIs) related to a utility’s managerial, financial, operational, and regulatory activities that can be used to measure internal performance and provide managerial guidance;
2. To enable an organisation to compare its performance on KPIs with those of other relevant utilities to identify areas needing improvement.

Kaplan and Norton (2007) introduced the concept of benchmarking perspectives, defining four areas on which organisations need to focus to ensure their survival. These are the financial perspective, the customer perspective, the internal business processes perspective, and the learning and growth perspective. During the 1990s, the said perspectives were supplemented by the social and the environmental

perspective, since the private sector is facing a growing challenge of contributing to the community while minding the physical environment in which it operates (Hubbard, 2009).

## BENCHMARKING AND PUCs

In addition to the private sector, benchmarking has found its way into the public sector, as well, especially during performance evaluation of PUCs. The first regional benchmarking programme focusing on utilities was initiated in 2000 – WUP for Capacity Building in Africa, SPBNET (Berg, 2007). Considering that PUCs are expected to meet the constantly growing consumer demands, it is necessary to first analyse their performance over time. Benchmarking is the very tool that a PUC can use to compare the efficiency of its processes and procedures for performing a variety of functions against similar utilities in other parts of the country or region or against international good practice standards. For instance, a PUC may compare its billing system against a system used by another PUC and decide which system performs better. After the benchmarking has revealed that one system outperforms the other, the PUC using the underperforming system may adapt and internalise new processes and procedures as needed (Danilenko & Berg, 2011).

The core issue of PUC managers and key stakeholders (e.g. municipal government, regulatory body, and the wider public) is the information about whether the local self-government or entity is properly managed. Poor PUC management leads to excessive costs, reduced business income, and reduced quality of services. The starting point for a typical private company would be to determine whether or not the company earned a profit. However, utility services provide significant social benefits that go beyond mere earning figures. The next logical step would be to consider the expenses of providing the services, but such figures cannot inherently indicate whether a PUC is properly managed. For example, with regard to water supply, costs may differ considerably from one place to another, and numerous factors may be responsible.

Benchmarking allows PUCs to identify what they are doing, how they are doing it, how others are doing it, how well they are doing it in terms of the standards and best practice/performance, and what and how needs to be improved. In addition, benchmarking allows PUC managers to identify and prioritise key areas to be improved, seeking the best operating practices in those areas and adapting the practices to the measures that improve the company’s performance. Benchmarking is not a one-time exercise, but a tool for continuous performance improvement that is highly beneficial when applied systematically over a specified period. The person(s) implementing the benchmarking plays one of the key roles, considering that they manage the collected information, which serves as the basis for business improvement (González de Asís et al., 2009).

## BENCHMARKING IMPLEMENTATION IN WATER AND SANITATION COMPANIES

The water management sector has an economic as well as symbolic significance for the citizens of developing countries. Benchmarking was introduced to the water and sanitation sector in the 1990s (Kurian and McCarnei, 2010). The following definition of benchmarking by the International Water Association (IWA) is the one most frequently used and generally accepted within the water industry: “Benchmarking is a tool for performance improvement through systematic search and adaptation of leading practices”. The IWA published manuals for water supply (Alegre et al., 2006) and wastewater (Matos et al., 2003) benchmarking. The manuals define hundreds of performance indicators, providing their definitions and access to their selection.

Water and sanitation utilities require performance assessment and measurement for multiple reasons. For the PUCs themselves, improved management may require higher efficiency, better communication with consumers, and better self-advertising. A performance assessment may also be requested by the authorities, as parts of the regulatory system for public utilities.

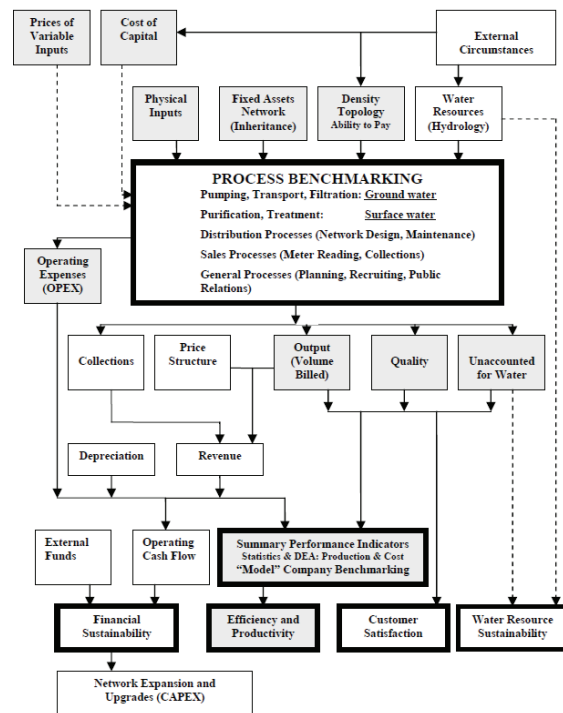
The main challenge for measurement, and ultimately benchmarking, of water and sanitation performance is the lack of standardised information. In rare cases, a standard set of indicators can be consistently used to measure both the financial and operational performance of PUCs (Danilenko & Berg, 2011).

The most commonly used benchmarking methods in water and sanitation include metric benchmarking and process benchmarking (Seppala, 2015).

Metric benchmarking involves a systematic comparison of the performance of one service programme against the performance of other similar service programmes and, more importantly, it involves the monitoring of the performance of one programme over time. A water and sanitation utility can compare itself against other similar-size utilities in the same country or abroad. Similarly, state regulators can compare the performance of the country’s PUCs. Metric benchmarking, which is essentially an analytical tool, can help PUCs to better understand their performance. Such benchmarking is at its most powerful when implemented over time, monitoring performance changes year after year (Danilenko & Berg, 2011).

Process benchmarking is a mechanism of identifying specific work procedures to be improved by emulation of external examples of excellence that can be set as the best standard (Parena & Smeets, 2001). Therefore, process benchmarking is usually understood as identification of failing key processes and comparison with the best-in-class organisations to learn best practice. Process benchmarking also requires direct and open relationships with other selected partner

companies (Milnes, 2006). Figure 2 shows the typical inputs, processes, outcomes, and the benchmarking system for water utility processes (Berg & Padovski, 2007).



**Figure 2.** Typical inputs, processes, outcomes, and the benchmarking system for water utility processes (Berg & Padovski, 2007)

Water utilities often apply both metric and process benchmarking. Metric benchmarking can be used to define areas or functions that need to focus on performance assessment. The results of metric benchmarking can then be analysed in more detail as part of the process benchmarking to understand the current performance levels in specific areas (Seppala, 2015).

Benchmarking provides a comprehensive, global view of the performance of a country’s utilities. It also correlates technical performance with financial performance and calculates specific measures of the overall efficiency of a utility. Only with such a broad perspective can policy makers decide on the best direction in which to take the sector as a whole (Danilenko & Berg, 2011). Likewise, benchmarking promotes transparency. When the same data are collected from every utility, benchmarking allows direct comparisons between service providers in terms of operational results, system conditions, quality of service and coverage, financial state, customer affordability, and other dimensions of utility’s performance. For PUCs, such reporting is often a legal requirement, while for private utilities or utilities intending to become private, the publication of performance data represents both sound corporate governance and a way to attract private capital.



Development banks such as the World Bank and the Asian Development Bank have supported the benchmarking of water utilities in several ways, helped develop suitable performance indicators (WSP, 2006), and promoted the use of benchmarking and performance comparison. The best-known among them is IBNET, the global benchmarking network supported by the World Bank, covering over 3,500 utilities (Danilenko et al., 2014).

### **IBNET database**

The International Benchmarking Network for Water and Sanitation Utilities (IBNET), launched in 1996, offers options for standardised measurement of operational and financial performance of utilities. IBNET established the first global benchmarking standard for water and sanitation utilities, providing a “global yardstick” with which utilities and policy makers can measure their performance and thus better understand their strengths and weaknesses. IBNET has around 3,500 registered users, who download up to 10,000 benchmarking reports each month; IBNET information is widely used by utilities, researchers, consultants, investors, and donors (Danilenko & Berg, 2011).

IBNET comprises three main tools. The first one is the IBNET Data Collection Toolkit, which can be downloaded from the IBNET website. An Excel table they created indicates a set of data to be entered and provides detailed instructions on the precise data to be entered. The second tool is a continuously updated database on the performance of water and sanitation utilities. This database allows the utilities and other sector stakeholders to search for data in various formats and provides the means for simple benchmarking of data on utilities. The benchmarking tool allows a utility to compare itself against other utilities with similar characteristics (e.g. size, location-related factors, and management structure). The third tool provides data on all the agencies involved. This information helps organisations interested in utility performance measurement to contact other utilities or other organisations in order to build local networks for performance assessment and benchmarking.

IBNET has three key aspects, the first of which is that participation is voluntary, which is why organisations contributing to IBNET are very diverse. The second aspect of IBNET is that it does not collect data by itself, but establishes mechanisms that many different organisations then use to collect data. From the very beginning, IBNET’s strategy has been to take a highly decentralised approach. Those closest to the utilities and those who know the most about local conditions are the most suitable to collect data and assess the performance of utilities. IBNET organises workshops to assist local agencies in staff training for data collection and analysis and provides feedback once the data have been collected. In its feedback, IBNET checks the quality of the data in order to ensure internal

consistency and helps participants to analyse the data. The third, key, characteristic of IBNET is its focus on time-series data development. Without time-series data, it is difficult to detect trends in utility performance and the influence of water and sanitation policies. Efficient time-series data development requires that the data remain comparable over time through rigorous use of a standardised data set and indicators and that the data be updated as frequently as possible. In IBNET’s practice, the majority of the data are updated biennially. As performance assessment and benchmarking keep growing in importance in the sector as regulation and monitoring tools, it has become easier to obtain data annually, especially in countries with increasingly institutionalised performance assessments.

### **Key performance indicators (KPIs) and their selection**

Key Performance Indicators (KPIs) are “financial and non-financial measures used on different organisational levels to assess the success of achieving defined goals and the critical factors of success, strategy, and planning, as well as the fulfillment level of stakeholder expectations” (Ferreira & Otley, 2009). KPIs “are a set of measures focused on those aspects of the organisational performance that are most critical for the current and future success of the company” (Parmenter, 2007). KPIs are used to assess the real state of business and set the main courses of action in the future. In addition to numerical, they also include quantities that are more difficult to measure, such as development benefits, commitment, serviceability, satisfaction, etc. Originally, KPIs were used to determine organisational strategies and measure the progress of goal accomplishment, especially of qualitatively defined goals. The core application of KPIs is in establishing measurements for organisations to supervise their own quality parameters. Identification of KPIs and the accompanying measures helps institutions set priorities for using resources and align their processes to achieve outcomes (Ballard, 2013).

KPIs are widely recognized as a basis for evaluating water utilities in developing countries and for designing regulatory and managerial incentives that improve performance. For a performance indicator to be “key”, it must encompass some dimension of performance that is important to those who currently receive or expect to have access to a service in the future. Entities responsible for oversight of infrastructure services and for delivery of those services should reach a consensus about what is valued and what is feasible. In general, legislation will identify the performance dimensions that elected representatives wish to improve: for example, water supply should be affordable, produced efficiently, and available throughout the given country. Key performance objectives may include availability, network outage impact reduction, the resilience of operations to extreme events (including weather conditions and conflicts), quality of service, downtime,

notification of delivery problems, customer satisfaction (via surveys or number of complaints), the integrity of billing and collection processes, affordability, access, efficiency, productivity, innovation, and safety. These goals can then be associated with a set of KPIs. Once the objectives have been prioritized and the data collection has begun, the performance evaluation can begin, first by starting small, and then slowly increasing the number and accuracy of KPIs. Another advantage of starting with objectives is that indicators that are “easy to measure, but are relatively unimportant” will not become the focus of performance evaluation. KPIs represent the foundation for those who develop, implement, and respond to public policies, wherein they incentivise water utilities in developing (and developed) countries to contain their costs, improve the quality of their services, and expand water access in the long run (Berg, 2020). KPIs are also

increasingly used by regulatory bodies to analyse and review organisations; performance, to compare organisations, and to measure progress against the set objectives. They are assessment tools enabling regulators to assess the performance of water supply services.

Different organisations, such as the International Water Association (IWA), the World Bank Group, and a wide array of national regulators, have established lists of KPIs to assess the performance of utilities. However, such lists are designed with different goals in mind and are not easily cross-adapted in different European countries.

Table 1 shows the most commonly used KPIs in water and sanitation (ESAWAS, 2017).

**Table 1.** Most commonly used KPIs in water and sanitation (ESAWAS, 2017)

Indicator	Definition	Calculation	Acceptable boundaries	
<b>QUALITY OF SERVICE</b>				
1	Water Coverage	% of total population with access to improved water supply: individual household connection, kiosk, public standposts, communal/shared tap	[Total Population Served/Total Population in the Service Area]	75-90%
2	Sewerage Coverage	% of total population with access to sewerage services (no septic tanks)	[Total Population Served/Total Population in the Service Area]	40-70%
3	Water Quality Residual Cl (w0.4) Bacteriological (w0.6)	% of water samples undertaken meeting quality requirements	% of tests compliant in relation to applicable / national standards	90-95%
4	Hours of Supply	Aggregated average hours of supply (per town/zone/area, etc.) in the reporting period	Sum of weighted averages per town	16-20
<b>ECONOMIC EFFICIENCY</b>				
5	O&M Cost Coverage by Billing	The level of costs covered by billed amounts	[Billed Amount/O&M Costs]	100-150%
6	Collection Efficiency	The collected amounts from the billing	[Collected amount/Billed amount]x100	85-95%
7	Staff Cost	Personnel Cost as a proportion of O&M cost	[Personnel Cost/ O&M Costs]*100	30-35%
<b>OPERATIONAL SUSTAINABILITY</b>				
8	Staff/1000 households	Staff per 1,000 water & sewerage households	[Total Number of Staff x 1,000]/[No. of Water + Sewerage households]	5-8
9	NRW	Water that does not produce revenue in a given period	[System Input Volume (imported + produced) – billed Volume]/System Input Volume	30-35%
10	Metering Ratio	The proportion of metered customers from the total	[Functional Metered Connections]/Total Connections]x100	85-95%

KPI selection is one of the major problems in designing a performance measurement system (Globerson, 1985). There are numerous recommendations on how to develop a performance measurement system, with one of the most prominent being that the system needs to “reflect most of the stakeholders’ requirements” (Bititci, Carrie, & McDevitt, 1996).

## CONCLUSION

Business excellence is the basic determinant of survival growth, and development of businesses in an increasingly turbulent environment. This is precisely why it is necessary to measure the state of business excellence and the set objectives, and benchmarking is the recommended technique for such measurements.

In the water and sanitation sector, benchmarking is advertised as a cost-effective and efficient tool that helps improve the performance of water utilities. Benchmarking of water utilities cannot improve the performance in the water sector on its own, but it can help resolve conflicts regarding design and implementation of business policies. Many national benchmarking initiatives are undertaken across Europe, whereby water utilities are benchmarked against other water utilities in a given country. These initiatives are undertaken either by national associations alone or in partnership with the regulators. The goal of using benchmarking is to guarantee good or even improved performance to the clients.

Generally, benchmarking is a voluntary process, which depends on the interest, willingness, and capacity of participants. Therefore, all communication associated with benchmarking results should be defined by the participants, and the recommendation is that it remain anonymous, so as to avoid any undesirable effects and thus protect the participants aiming at higher standards from being publicly criticised. With benchmarking, it is important to understand which benefits can be expected before any expensive resources are invested. Reaching an acceptable level of reliability requires great effort in terms of commitment by the management. It requires time, good data quality, sufficient resources to ensure data quality, and database maintenance.

Internationally, benchmarking is generally accepted, although participation in benchmarking schemes is still fairly small. Since the availability of drinking water that meets both quantitative and qualitative criteria is one of the basic human rights, the use of benchmarking in this sector would be of special importance. Unfortunately, Serbian PUCs still lack a developed organisational culture of using benchmarking. The aim of this paper was to present the benchmarking technique and its significance for continuous improvement of PUCs' operations, which opens up various possibilities for future research.

## REFERENCES

- Alegre, H., Baptista, J.M., Cabrera, E.J., Cubillo, F., Duarte, P., Hirner, W. and Parena, R. (2006). *Performance Indicators for Water Supply Services*, 2nd ed., International Water Association, London, UK.
- Ballard, P. J. (2013). *Measuring performance excellence: Key performance indicators for institutions accepted into the academic quality improvement program (AQIP)*. Western Michigan University.
- Berg, S. V. (2007). *Conflict resolution: Benchmarking water utility performance*. Public Admin. Dev. 27, pp. 1–11.
- Berg, S. V. (2020). *Performance Assessment Using Key Performance Indicators (KPIs) for Water Utilities: A Primer*. Water Economics and Policy, 6(2), pp. 1-25.
- Bititci, U. S., Carrie, A. S., & McDevitt, L. (1996). *Performance Measurement: A Business Process View*. In IFIP WG 5.7 workshop on Modelling Techniques, Business Process and Benchmarking. Bordeaux, France.
- Cabrera, Enrique Jr. (2008). *Benchmarking in the Water Industry: A Mature Practice?* Water Utility Management International, June 2008.
- Camp, R. (1989). *Benchmarking: The Search for Industry Best Practices that lead to Superior Performance*, Milwaukee.
- Danilenko, A., van den Berg, C. (2011). *The IBNET Water Supply and Sanitation Blue Book 2014: The International Benchmarking Network for Water and Sanitation Utilities Databook*, The World Bank, Washington DC. 10.1596/978-0-8213-8582-1
- Danilenko, A., van den Berg, C., Macheve, B. and Moffitt, L.J. (2014). *The IBNET Water Supply and Sanitation Blue Book 2014: The International Benchmarking Network for Water and Sanitation Utilities Databook*, The World Bank, Washington DC.
- ESAWAS regulators association. (2017). *Regional benchmarking of large water supply and sanitation utilities 2015/2016 report*.
- Ferreira, A., & Otley, D. (2009). *The design and use of performance management systems: An extended framework for analysis*. Management Accounting Research, 20(4), pp. 263–282.
- Freiling, J., Huth, S. (2002). *Limitations and Challenges of Benchmarking – A Competence – based Perspective*. 6<sup>th</sup> International Conference on Competence-based Management Lausanne, October 26th-28th, 2002 IMD, Lausanne, Switzerland.
- Globerson, S. (1985). *Issues in developing a performance criteria system for an organization*. International Journal of Production Research.
- González de Asís, M., O'Leary, D., Ljung, P., Butterworth, J. (2009). *Improving Transparency, Integrity, and Accountability in Water Supply and Sanitation - Action, Learning, Experiences*. The International Bank for Reconstruction and Development / The World Bank, Washington, DC.
- Hubbard, G. (2009). *Measuring organizational performance: beyond the triple bottom line*, Business Strategy and the Environment, 18(3), pp. 177–191.
- Kaplan, R.S. and Norton, D.P. (2007). *Using the balanced scorecard as a strategic management system*, Harvard Business Review, July/August, 85(7–8), pp. 150-161.
- Kurian, M. and McCarney, P. (2010). *Peri-urban Water and Sanitation Services: Policy, Planning and Method*, Springer Science and Business Media, Springer Netherlands.
- Marković, Lj., Dutina, V., Kovačević, M. (2011). *Application of benchmarking method in the construction companies*. Facta Universitatis, Architecture and Civil Engineering, 9(2), pp. 301–314.
- Matos, R., Cardoso, A., Ashley, R., Duarte, P., Molinari, A. and Schulz, A. (2003). *Performance Indicators for Wastewater Services*, IWA Publishing, pp.192.
- Milnes, D. (2006). *Metric and Process Benchmarking for Utility Optimisation*. Water Research Centre. Available at

[https://www.ewaonline.eu/tl\\_files/\\_media/content/documents\\_pdf/Publications/EWAter/documents/32\\_Pres\\_7\\_Milnes.pdf](https://www.ewaonline.eu/tl_files/_media/content/documents_pdf/Publications/EWAter/documents/32_Pres_7_Milnes.pdf)

Parena, R., Smeets, E. (2001). *Benchmarking Initiatives in the Water Industry*. Water Science and Technology, VASS, 2014. Introduction to Svenskt Vatten's Benchmarking System, 44(2-3), pp. 103-110.

Parmenter, D. (2007). *Key Performance Indicators - Developing, Implementing, and Using Winning KPIs*. New Jersey: John Wiley & Sons, Inc.

Seppala, O. (2015). *Performance benchmarking in Nordic water utilities*. 8<sup>th</sup> Nordic Conference on Construction Economics and Organization. Procedia Economics and Finance 21, pp. 399-406.

WSP. (2006). *Urban Water Sector in South Asia: Benchmarking Performance*, WSP field note, World Bank, Washington, DC.

Zakon o komunalnim delatnostima [*Law on Public Utilities*] ("Official Gazette of the Republic of Serbia", no. 88/2011, 104/2016, and 95/2018)

## ACKNOWLEDGEMENTS

This paper is a result of research funded by the Ministry of Education, Science and Technological Development of the Republic of Serbia pursuant to agreement No. 451-03-68/2022-14/200148.

## BIOGRAPHY of the first author

**Ana Stojanović** was born in 1995 in Čačak. She is a PhD student at the Faculty of Occupational Safety in Niš, where she also received her bachelor's degree and two master's degrees – in environmental engineering and in disaster and fire protection engineering.



Since June 2020, she has been a grantee of the Serbian Ministry of Education, Science and Technological Development for the research field Management, Protection, and Use of Water, Land, and Air.





NIKOLA MITROVIĆ<sup>1</sup>  
MILAN ĐORĐEVIĆ<sup>2</sup>  
SANDRA VELJKOVIĆ<sup>3</sup>  
DANIJEL DANKOVIĆ<sup>4</sup>

<sup>1,3,4</sup>University of Niš,  
Faculty of Electronic Engineering  
<sup>2</sup>University of Niš,  
College of Applied Technical  
Sciences

<sup>1</sup>nikola.i.mitrovic@elfak.ni.ac.rs

<sup>2</sup>milan.nebojsa.djordjevic@gmail.com

<sup>3</sup>sandra.vejlkovic@elfak.rs

<sup>4</sup>danijel.dankovic@elfak.ni.ac.rs

## DESIGN OF IOT PLATFORM FOR AIR QUALITY MONITORING SYSTEM

**Abstract:** *This paper gives insight into the design and testing of the IoT system that tackles one of the rapidly emerging environmental issues, testing and monitoring of air quality. Raising awareness about air quality using widely accessible concrete measured values should initiate further measures to solve this environmental issue. The paper provides an example of a solution that can monitor the presence of certain gases and compounds that impact overall air quality and have an indirect influence on health but can also share monitored data with the wider community in real time. The design of both the hardware part and the software part of the IoT platform is explained and the system is tested under different conditions. Results of the measurement are presented and compared to similar solutions and different standards.*

**Key words:** air quality, environment monitoring, Internet of Things, CO emission.

### INTRODUCTION

The recent development in electronics and wireless communications enabled the design of systems that can collect a lot of data, enable fast data transfer, and remain affordable in price. This type of system can be used to address one of the rising environmental problems, which is determining and maintaining air quality. According to the annual report on the air quality of the Republic of Serbia for 2019, there were occasions when the air concentrations of some pollutants exceeded target values [1]. The report revealed that these exceedances were noticed mostly in urban areas and that several cities in Serbia are categorized in category III, i.e., over-polluted air. Similar results are delivered with the report from the Institute of Public Health of Serbia "Batut" [2], where a growing trend has been noticed. These official documents point out that the quality of the air, as an environmental issue, should be investigated and dealt with more dedication. These reports also point out the fact that there is not enough measurement involved with these types of threats. In many places, there is no measurement at all, while only the big cities employ all of the wider standard measurements [2].

In order to establish appropriate measures and legislatures, it is first needed to carry out measurements that will determine and pinpoint critical problems and areas, so that measures can really be effective. For this process, it is also important to enable transparency of the data, so that all of the stakeholders can be equally informed. One of the solutions that can cover both of these aspects is an Internet of Things (IoT) platform that enables monitoring of the concentration of the specified substances in the air, as noted in many Smart

city approaches [3, 4]. With this approach, based on those concentrations, it is possible to give an assessment of the air quality and to share measured results with the community.

There are successful examples of using similar solutions in the literature. *Dhingra* proposed a solution that measures the concentration of specific gases in Bengaluru, India [5]. Collection of data is done using devices from the MQ series. Results are measured on Arduino device and then sent to the server using other. Certain access to the measured data is enabled. *Setiawan* presented a device that uses a similar measuring method, but employs an Espressif microcontroller for both measuring and data transmission [6]. Electronic circuit is given and basic concepts are explained. Limited access to the measured data is possible, but the data is not public. *Marinov* concentrated on air quality monitoring in urban environments [7]. A system that can measure NO<sub>2</sub> and CO concentration is built around a PIC microcontroller, where different data transfer methods are enabled using additional circuits. Data is measured for a longer period of time, with the public representation of data.

The IoT platform presented in this paper adopts the advantages of the earlier presented solutions with the attempt to decrease and limit disadvantages, mainly in dimensions and power consumption.

### DESIGN OF THE PLATFORM

The design of the IoT platforms can be generally divided into two parts, the design of the hardware part (measuring part) and the design of the server application (software part). Both of the parts will be explained in more detail.

### Hardware part

This part of the system consists of devices needed for measuring and processing of data. Data is collected using different sensors. The main sensor used is MiCS-5524 [8]. The MiCS-5524 is a robust micro-electromechanical system (MEMS) for carbon monoxide and natural gas leakage detection, suitable mostly for indoor air quality monitoring. It comes with a simple interface for connection with other devices.

An additional device that gives information on air quality is ZP07-MP503 [9]. This device is pre-calibrated and sensitive to carbon monoxide and cigarette smoke. It cannot measure the exact concentration of these compounds, but it can give information about whether this concentration is lower or higher than pre-calibrated values. It is implemented in the system mostly as a controlling factor for the measurement of MICS-5524.

Besides these sensors, also BME280 module is used [10]. This device can measure air temperature, humidity and pressure. It is included in this type of system for more comprehensive measurements, but also as a corrective factor for the reliability of other measured data.

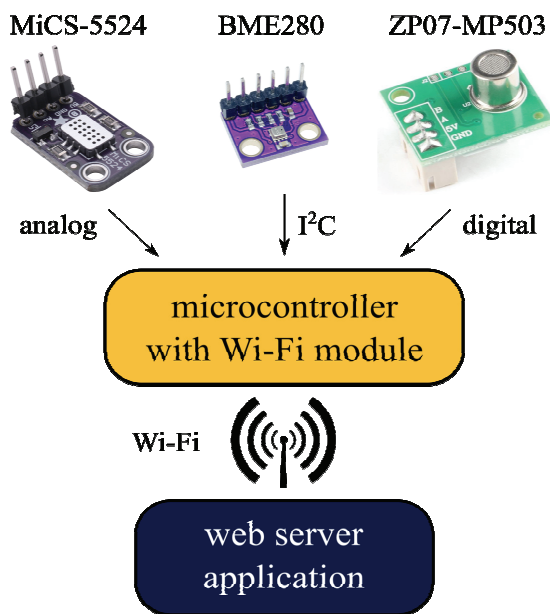


Figure 1. Block schematic of the designed IoT platform

All of these measuring subunits communicate with the central unit. The central unit is built around an ESP12-E chip [11]. This module is the improved version of the widely known ESP8266 chip. This chip is selected for this application because it incorporates a microcontroller and a Wi-Fi module on a single chip. This will enable both the processing and sending of the data on the same chip. Also, the chip possesses a submodule for interface with other devices used in this system.

For more compact access to the system, a custom printed circuit board is designed to connect all of the needed components on a board and to enable access to

additional peripherals. Components are then soldered and manufactured. This process is shown in Fig. 2.

Data from MiCS-5524 is processed and some basic data is shown on a miniature OLED display that is connected to the device in the debugging phase. After processing, data is sent through Wi-Fi to the server, for further management.

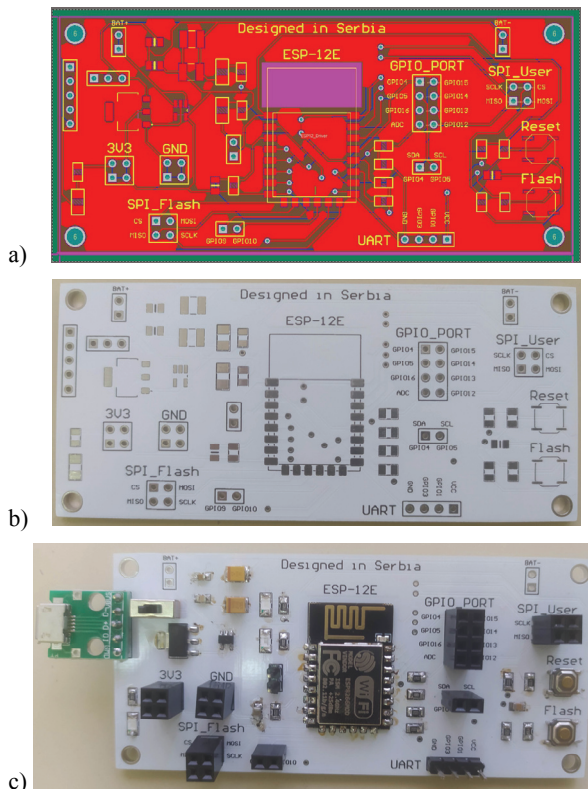


Figure 2. Designed PCB with MCU with Wi-Fi module: a) design and placement of components in a software tool; b) manufactured PCB; c) PCB with soldered parts, ready for use.

### Software part

A publicly accessible software platform is designed with the goal to enable data transparency. The platform is designed as a web application that should constantly receive measured data from the hardware unit and ensure a clear presentation of that data to the users. Logging of data is done on an hourly basis. The interface of the platform is shown in Fig. 3.

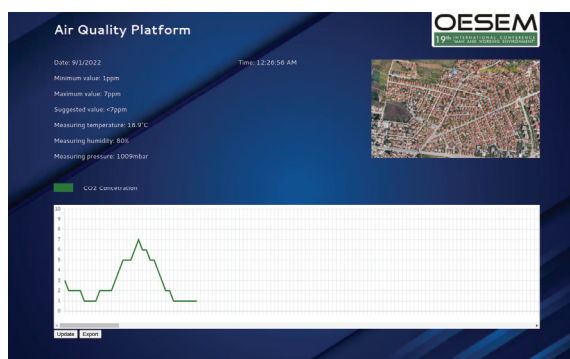


Figure 3. Interface of the designed platform.

The front end of the platform consists of a graph that presents received values from the last three days. Based on the values, the platform web application can inform users about exceeding some critical values, or about some possible system malfunction. The interface also has several measured values and a couple of buttons.

The graph only shows values measured at MiCS-5524, since it directly impacts CO concentration and thereby influences the air quality. Other measured values (temperature, humidity and pressure) are presented only for the last measurement. However, using buttons in the bottom left corner, the user can export all of the measured values for the last seven days, together with the time of the measurement. This functionality is added for more reliable data analysis, since some peaks and instabilities in this type of measurement can occur. The right side of the interface is assigned to the image of the geographical position of the measuring unit. This type of data can be very useful for a more accurate assessment of the measured data. Besides, all of the gas sensing devices have a relatively small area of distinction. Increased pollution in one part of the city does not necessarily determine the overall level of pollution.

The backend side of the platform web application handles data transfer processes. Data transfer between the measuring point and the web server is done using the WebSocket method. This method appeared superior for this application, as stated in similar research [12, 13]. In the WebSocket configuration, the platform web application that is deployed is marked as a server, while a measuring unit is marked as a client. This data transfer method is selected because it enables addition of more client units in a single configuration if necessary. Designed web application is publicly available at: <https://pollution-checker.herokuapp.com/>. The web application updates in real-time and enables simultaneous monitoring on multiple devices.

## RESULTS AND ANALYSIS

Several experiments have been carried out with the goal to obtain measured data that can be reliable and further analysed. Obtained data is then compared to similar researches. Deviations in data and some additional considerations are also discussed.

### Experimental results

The designed system is first put to use in an indoor environment. The goal was to test both the measurement of the concentrations and data sending and presentation. During this testing measurement, measured data on the hardware unit was checked constantly to ensure that the measured and processed data from the hardware unit is the same data that is being shown on the interface of the web application. Results are shown in Fig. 4.

Fig. 4 illustrates the measurement of the system for 24 h. The green line presents data measured with MiCS-5524, while the purple line presents data

measured with ZP07. As can be seen from the figure, and as stated earlier in the paper ZP07 device does not give a concrete value of the concentration of some gas. It can only give information on whether a concentration is in a certain range.

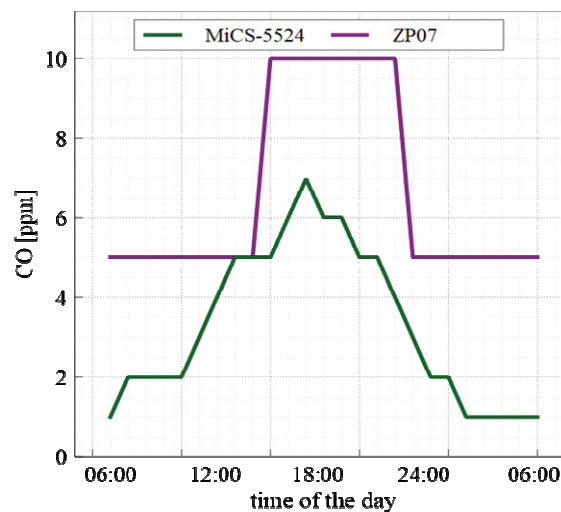


Figure 4. Data collected during one day.

Borders of range can be partially calibrated, and here are used as a controlling factor to monitor if MiCS gives reliable data. When the concentration of CO is greater than 5 ppm, ZP07 shifts to the next pollution grade. For most of the measurements, measured data from one sensor is in line with the measured data from the other one, although there are some corner cases. For the measurement at 13:00, the measurement from the MiCS shows CO concentration between 4 and 5 ppm, while ZP07 shows 10 ppm. This can be significant in some cases, so presenting two separate sensors for measuring is essential for these types of solutions.

An additional round of experiments was conducted, but this time under outdoor conditions. Measuring hardware unit was put on the window of the house, so that measuring can be influenced by both indoor and outdoor conditions. For this measurement, the device was positioned on the territory of the municipality Pantelej in the city of Niš, Serbia, as shown in the right part of Fig. 3. This time, data was logged for three days. The goal of this experiment was to add the impact of the outdoor surroundings where the atmospheric conditions also impact the measurement results. As stated in datasheets of used devices and in other researches, temperature and humidity differences have a direct impact on the output of the used sensors because they affect the airflow that covers the sensors [8, 9, 14]. An increase in the temperature and humidity of the air flowing on the sensor reduces the sensitivity of the sensing element of the sensor and creates a shift in measured data. Deviations of measured data are generally higher for greater measuring temperatures and humidity. The results of this measurement are given in Fig. 5.



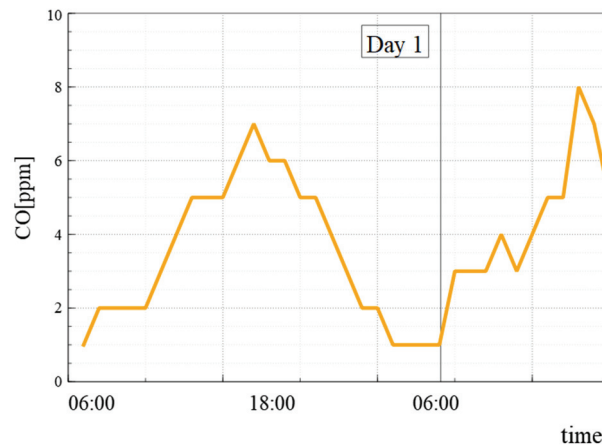


Figure 5. Measurement data collected during three days.

As can be seen, there is a difference between the measured concentration of CO in the air during the daylight and during the night. The measured concentration is lower during the night. These differences are most likely the result of increased traffic during the day and an overall increase in activity. According to the research by Popović [15], measured values are in the scope of category that does not impact human health noticeably, meaning less or equal to  $10 \text{ mg/m}^3$ , or less or equal to 8 ppm. Jevtić and Mumtaz also reported similar results for other measuring conditions [16, 17]. During the measurement, the temperature was stable between  $15.6 \text{ }^\circ\text{C}$  and  $26.1 \text{ }^\circ\text{C}$ , so the temperature should not impact drastically the measured results. Similar results can be found for the impact of humidity. Most of the time, the humidity is between 40 % and 60%, but it tends to increase in the mornings (more than 80 %). Because of that, it could be assumed that the values of concentrations in the morning could be slightly higher.

On the other hand, it should be taken into consideration that these results were measured in a municipality that is not a city center, during the second half of August when many people are on vacation, when a lot of people use bicycles and walk instead of driving (unlike in autumn and winter) when the airflow is increased because of the heat. For a more comprehensive analysis, measurements must be taken during the entire year, so that many other factors can be taken into consideration.

The system itself can be improved by allowing for a variety of data transfer methods so that it can send data using GSM or other similar technologies without needing a Wi-Fi connection. Also, it is possible to attach additional sensors that can measure and detect concentrations of additional gases, making the device adaptable to some special environments (big factory facilities or storehouses). On the software part, a server application can be improved with some cross-platform applications that can notify the user about increased concentrations of some pollutants or give brief

reminders about a proactive approach to environmental protection.

## CONCLUSION

Although this kind of system enables monitoring rather than directly altering air quality, it is still viewed as a necessary step in the process of involving more stakeholders and leading to measures that make direct changes. Future steps of the research include increasing the number of hardware units so that users from different municipalities of the city can get even more accurate information about the air quality of the surrounding areas.

## REFERENCES

- Environmental Protection Agency of the Ministry of Environmental Protection of Serbia, "The Annual Report on the Air Quality in the Republic of Serbia", 2019, ISSN 2334-8763.
- The Institute for Public Health of Serbia "Milan Jovanović Batut", "Urban air pollution in the territory of the Republic of Serbia measured with the network of public health institutions in 2020", 2021,
- G. Marquez et al., "Indoor Air Quality Monitoring Systems for Enhanced Living Environments: A Review toward Sustainable Smart Cities", *Sustainability*, vol. 12, no. 10, p. 4024, 2020.
- S. Munir et al., "Structuring an integrated air quality monitoring network in large urban areas – Discussing the purpose, criteria and deployment strategy", *Atmospheric Environment*, vol. 2, p. 100027, 2019.
- S. Dhingra et al., "Internet of Things Mobile - Air Pollution Monitoring System (IoT-Mobair)", *IEEE Internet of Things Journal*, vol. 6, no. 3, pp. 5577-5584, 2019.
- F. N. Setiawan and I. Kustawian, "IoT based Air Quality Monitoring", *IOP Conf. Series: Materials Science and Engineering*, vol. 384, p. 012008, 2017.
- M. Marinov et al., "Air Quality Monitoring in Urban Environments", in Proc. of the 39th Int. Spring Seminar on Electronics Technology (ISSE), pp. 443-448, 2016.

MiCS-5524 datasheet, Sensortech, 2018.

ZP07-MP503 datasheet, Winsen sensors, 2018.

BME280 datasheet, Bosch, 2022.

ESP12-E datasheet, Espressif, 2015.

N. Mitrović et al., "Testing the efficiency of Wi-Fi data transmission in ESP-based IoT systems", in Proc. of the Int. Conf. on E-business technologies (EBT), 2021, pp. 110-112.

N. Mitrović et al. "Implementation of WebSockets in ESP32 based IoT systems", in Proc. of the 15th Int. Conf. Adv. Technol. Syst. Services in Telecommunications (TELSIKS), 2021, pp. 261-264.

Abdullah et al., "Development of MOX Gas Sensors Module for Indoor Air Contaminant Measurement", *IOP Conf. Series: Materials Science and Engineering*, vol. 705, p. 012029, 2019.

T. Popović, "Report on air quality protection at the local self-government level in the Republic of Serbia", National Association of Local Authorities in Serbia, 2020.

R. Jevtić et al., "Installation of Carbon Monoxide Detectors", *Tehnika*, vol. 74, no. 1, pp. 152-158, 2019.

R. Mumtaz et al., "Internet of Things (IoT) Based Indoor Air Quality Sensing and Predictive Analytic—A COVID-19 Perspective", *Electronics*, vol. 10, p. 184, 2021.

## ACKNOWLEDGEMENTS

This work was supported by the Republic of Serbia under Grant No. 451-03-9/2021-14/200102.

## BIOGRAPHY of the first author

**Nikola Mitrović** was born in Niš, Serbia, in 1994. In 2018, he received a master's degree in electronics and microsystems, at the Department of Microelectronics, Faculty of electronic engineering in Niš, where he is currently a Ph.D. student.



His main areas of research include the reliability of electronic devices and the Internet of Things.

He is currently working as a Teaching Assistant at the Faculty of Electronic Engineering in Niš, University of Niš.





UNA MARČETA<sup>1</sup>  
BOGDANA VUJIĆ<sup>2</sup>  
JELENA VUKOVIĆ<sup>3</sup>

<sup>1,2</sup> University of Novi Sad, Technical  
Faculty "Mihailo Pupin" Zrenjanin,

<sup>3</sup>University of East Sarajevo, Faculty  
of Technology Zvornik

<sup>1</sup>una.tasovac@tfzr.rs

<sup>2</sup>bogdana.vujic@tfzr.rs

<sup>3</sup>jelena.vukovic@tfzv.ues.rs.ba

## IDENTIFICATION OF CRITERIA FOR AIR QUALITY RISK ASSESSMENT ASSOCIATED WITH LANDFILL DUST EMISSION

**Abstract:** *The waste management system in the Republic of Serbia is currently based on elementary stages, making landfilling virtually the only method of treating collected waste. Also, the prevalence of unsanitary landfills and open dumps is considered one of the biggest problems. The aim of the research presented within the paper is to define how unsanitary landfills affect the risk of atmospheric pollution from the aspect of emission and atmospheric dispersion of particulate matter. The identified key criteria represent landfill characteristics that are relevant for air quality risk assessment associated with emissions and atmospheric dispersion of particulate matter. Four different types of criteria must be taken into account when assessing the potential risks to the environment and human health: landfill emission potential (landfill type, landfill size, waste composition), landfill infrastructure (landfill cover, transport activities) landfill vulnerability on the environment and human health (buffer zones, wind speed), and estimated PM emission rate from landfills (concentration levels of sedimentable particles).*

**Key words:** waste management, air pollution, landfilling, particulate matter

### INTRODUCTION

Proper municipal solid waste management is of crucial importance in order to prevent the negative impact of waste on the environment. This involves a series of complex procedures related to the minimization of waste generation, collection, sorting and treatment of waste, as well as its storage and final disposal (Minelgaite and Liobikienė, 2019). Given their economic advantages, landfill remains the most dominant method of solid waste management at the global level (Modak et al., 2015). Developing countries are most often faced with the problems of environmental degradation as a result of waste disposal in uncontrolled, unsanitary landfills, so the assessment of potential risks is of great importance when designing such facilities (Cointreau, 2006). The research conducted within this paper is focused on the impact of unsanitary landfills on ambient air pollution from the perspective of emissions and atmospheric dispersion of particulate matter.

Airborne solid particles or particulate matter (PM) are present all around us and have a wide range of sources, both natural and anthropogenic. Complex mixtures of organic and inorganic compounds suspended in the air are called suspended particles or atmospheric aerosols, given that they are mixtures of solid and liquid particles present in the air (Hinds, 1982). The terms particulate matter and dust are very often used as synonyms,

however, when dust generated from an emission source at a specific location is found in the ambient air, it is then called suspended particulate matter (Seinfeld and Pandis, 1998).

Depending on the method of formation, particles are divided into primary and secondary particles. Primary particles are emitted into the atmosphere directly from the source, retaining their original chemical form, while secondary particles are formed in complex atmospheric processes that occur due to the presence of precursor gases and other particles (ERDC, 1995). Another criterion for the classification of PM is their size, which is particularly significant from the aspect of the impact of particles on health and the environment. Smaller particles are associated with greater risk due to their ability to penetrate deep into the lungs and enter the bloodstream, but also to be transported far from the emission source. Small particles are classified as coarse particles - PM<sub>10</sub> (less than 10 μm), fine particles - PM<sub>2.5</sub> (less than 2.5 μm), and ultrafine particles - PM<sub>0.1</sub> (less than 0.1 μm) (Franek and De Rose, 2003). Particles with an aerodynamic diameter of 10 - 100 μm are called Total Suspended Particles (TSP) (Chow and Watson, 1998).

The resuspension of dust in the atmosphere, which occurs under the influence of the wind, significantly affects atmospheric phenomena, and therefore the quality of the air and the health of the exposed

population, given that exposure to dust is associated with numerous health problems (Mukherjee and Agrawal, 2017). PM emissions from landfills occur primarily through resuspension due to soil erosion from the surface of the landfill body under the influence of wind, as well as due to transport activities on paved and unpaved roads at the landfill. A number of factors influence the dispersion of the resulting dust, including the dominant wind direction and speed, vehicle movement, type of deposited waste, and the presence and type of cover layers. In terms of negative impacts on human health, the consequences of emissions of resuspended particles from landfills, depend on the size of the dust particles and their chemical composition, which is a reflection of the chemical composition of the disposed waste and may include dangerous substances such as toxic trace metals. The majority of research to date has focused on the spatial distribution of pollution caused by mining and industrial production activities (Ozaki et al., 2019) while examining the impact of resuspended particle emissions from landfills on ambient air quality is an issue that has not been given enough attention.

The aim of this paper is to perform a preliminary identification of criteria for quantifying the risk of atmospheric pollution due to PM emissions from landfills in the Republic of Serbia (RS). Based on the United States environmental legislation and the legislation of the RS, four groups of criteria with certain sub-criteria were defined.

## RESULTS AND DISCUSSION

The waste management system in the RS is far from advanced treatment techniques, involving waste collection and disposal in open dumps, uncontrolled landfills and controlled city landfills that generally do not meet basic technical and technological requirements (Ubavin et al., 2018). Nearly 40% of landfills in Serbia are located in the immediate vicinity of populated areas (SEPA, 2005), which poses a risk to both the environment and the general public's health. The improvement of the waste management system in the RS, as well as in other countries of Southeast Europe, is hampered by the lack of financial resources necessary for the implementation of advanced technologies. In order to minimize human health and environmental risks, these locations require closure and remediation. However, due to the abundance of landfills and the lack of funding, it is necessary to categorize the existing landfills according to the risk associated with PM emission and atmospheric dispersion. In this regard, a preliminary identification of four groups of criteria was carried out, which include a total of 8 key factors for risk quantification (Table 1.).

**The first group of criteria** refers to the emission potential of the landfill as a source of ambient air pollution. Three subcategories of this group are defined based on factors that influence the potential of PM emissions from landfills:

**The type of landfill** greatly affects the emission of pollutants and must be taken into account as a criterion when assessing the risk of PM emission. Sanitary landfills meet the standards of the Landfill Directive (EU Directive 1999/31/EC) and pose a minimal threat to the environment and human health. On the other hand, deviation from these standards increases the risk of emissions originating from landfills. According to the data of the Serbian Environmental Protection Agency (SEPA), there are currently only 11 landfills in Serbia that are classified as regional sanitary landfills. Other landfills, where more than 80% of the generated waste is disposed of, are classified as unsanitary landfills (SEPA, 2021).

**The size of the landfill** is a criterion that implies the volume of disposed waste in cubic meters. The level of particulate matter emissions from landfills also depends on the size of the landfill. Due to the fact that they are based on estimates and that many landfills lack the necessary technical documentation, information on the size and volume of landfills in Serbia is not reliable. According to data for 2020, the total amount of generated waste per inhabitant is 1.8 t/inhabitant/year, while the total amount of deposited waste is close to 2 million tons (SEPA, 2021).

**The waste composition** is a criterion that refers to the percentage share of biodegradable disposed waste. The morphological composition of municipal waste in the RS according to data for 2020 shows that biodegradable waste makes up almost half of the total generated waste (SEPA, 2021). The share of the organic fraction was taken into account from the aspect of PM emission, because biodegradable waste is characterized by a high moisture content, which significantly reduces the resuspension of dust from the body of the landfill (Macklin et al., 2011). It can be said that with an increase in the share of organic fraction in the disposed waste, the potential of dust particle emission decreases (Jia et al., 2013).

**The second group of criteria** includes the infrastructural characteristics of the landfill, which are significant from the aspect of emission and atmospheric dispersion of dust particles from the landfill. The movement of vehicles on paved and unpaved roads was taken into account, as well as the activities of covering with inert material. Within this criterion, the following two sub-criteria were identified:

**The presence and type of covering material** also significantly affect dust emissions from landfills. Landfills are a source of fugitive dust, i.e. emissions that arise from open sources as a result of mechanical processes. This phenomenon is therefore related to the application of the cover layer, where the type of cover material is particularly significant in terms of moisture content. It is known that increased humidity reduces the fugitive emission of PM, which is, for example, the lowest in the winter period characterized by frequent precipitation and high air humidity (Kovačević, 2016).

*Transport activities*, i.e. the movement of trucks on paved and unpaved roads, are one of the main causes of the emission of dust particles from landfills (Chalvatzaki et al., 2015). Vehicle traffic on unpaved roads causes shredding of the pavement material and resuspension of dust (US EPA, 2006a). Dust emissions from paved roads are smaller and originate from the resuspension of loose material present on the surface due to the movement of trucks on a dry paved road (US EPA, 2006b.) According to the data of the SEPA Agency, most landfills in the RS do not meet basic sanitary and technical requirements, access roads and the roads connecting the facilities at the landfills are mostly unpaved and increase the risk of resuspension of dust particles.

**The third group of criteria** refers to the impact of landfills on the environment and human health and includes two sub-criteria. In this group of criteria, buffer zones are defined as areas where there is a potential impact of the landfill on the environment and the exposed population. In addition, wind speed was taken into account as a significant meteorological factor. Buffer zones and wind speed are important factors in risk assessment, considering that dust particles may be suspended in the atmosphere for a short period or for an extended period of time and that they may be transported over great distances downwind.

*Buffer zones* defined as the distance of the landfill from the first houses, i.e. the inhabited place, are a criterion that indicates whether a certain part of the population could be affected by pollution from the landfill due to the emission and atmospheric dispersion of dust particles. Buffer zones are most often defined at distances of 200-500 m. According to the United States Environmental Protection Agency (US EPA), a reasonable default buffer distance is 500 m and the risk to the environment from the landfill at distances less than 500 m is considered very small. According to SEPA research, of the total number of landfills in the territory of the RS, 7.3% are located less than 100 meters from settlements.

*Wind speed* is a meteorological factor that has a great influence on the resuspension of dust particles from the landfill, as well as their further spread in the ambient air. The rate of particle emission from landfills depends on particle size and wind speed (Jia et al., 2013, Chalvatzaki et al., 2015). It is known that significant emissions of dust particles from landfills due to wind erosion are possible when the wind speed is above 5 m/s (US EPA, 2006b). The percentage of time when the wind speed is above 5.4 m/s is a significant factor that is taken into consideration when calculating the emission factor for dust particles whose resuspension occurs under the influence of wind, according to the US EPA.

**The fourth group of criteria** takes into account the estimated PM emission rate from landfills.

*Concentration levels of sedimentable particles* can be taken into account when estimating the risk in terms of PM emission rates. In the RS, the Regulation on monitoring conditions and air quality requirements ("Official Gazette of the RS", no. 63/2013) prescribes a maximum permissible TSP value of 450 mg/m<sup>2</sup>/day for a one-month averaging period and 200 mg/m<sup>2</sup>/day for the entire year. Some commonly used parameters for monitoring dust emissions from landfill include dust deposition, and the US EPA agency prescribes a dust deposition emission limit value of 350 mg/m<sup>2</sup>/day.

The mentioned characteristics of the landfill and the deposited waste are important factors that must be taken into account for the estimation of the PM emission potential of the landfill site.

**Table 1. Identified criteria**

<b>IDENTIFIED CRITERIA</b>
<b>The first group of criteria - Landfill emission potential</b>
Landfill type
Landfill size
Waste composition
<b>The second group of criteria - Landfill infrastructure</b>
Landfill cover
Transport activities
<b>The third group of criteria - Landfill vulnerability to the environment and human health</b>
Buffer zones
Wind speed
<b>The fourth group of criteria - Estimated PM emission rate from landfills</b>
Concentration levels of sedimentable particles

## CONCLUSION

A large number of existing landfills in the Republic of Serbia do not meet basic sanitary and hygienic requirements and require closure and remediation. Solving this issue is crucial, not only due to legal obligations and other obligations defined in national strategies and plans developed during the process of joining the European Union but also due to the fact that landfills present a significant environmental risk.

Improvements in the waste management system include, among other things, the construction of regional sanitary landfills in accordance with strict technical rules, which is crucial for reducing the negative environmental impacts of waste disposal, as well as the closure of the existing unsanitary landfills. However, one of the biggest obstacles to solving this problem in developing countries is the lack of financial resources. By defining the key characteristics of landfills that contribute the most to dust resuspension and its impact on ambient air pollution, it is possible to

rank landfills based on risk assessment using the Multicriteria decision making (MCDM) methods.

The criteria were identified based on relevant literature sources and data analysis on Serbian landfills. Depending on the defined criteria for environmental risk quantification, landfills can be positioned based on the risk they pose, to first remediate the most critical ones. Landfill remediation is an expensive process and it cannot be performed for all landfills at the same time. Therefore, it is necessary to identify preferential landfills and, distribute the available funds accordingly.

## REFERENCES

Minelgaitė, A., Liobikienė, G. (2019). 'Waste problem in European Union and its influence on waste management behaviours', *Science of the Total Environment*, 667, pp. 86-93.

Modak, P., Wilson, D.C., Velis, C. (2015). *Waste management: Global status*, In: Wilson, DC, (ed.) *Global Waste Management Outlook*. UNEP, pp. 51-88.

Cointreau, S. (2006). *Occupational and environmental health issues of solid waste management: special emphasis on middle-and lower-income countries*, UP 2, World Bank, Washington, DC, USA.

Hinds, W.C. (1982). *Aerosol technology: Properties, behavior, and measurement of airborne particles (Book)*, New York, Wiley-Interscience.

Seinfeld, J.H., Pandis, S.N., Spyries, N., (1998). *Atmospheric chemistry and physics from air pollution to climate damage*, AVI publishing Co, West Print Connecticut.

ERDC (1995). *Contributions of fuel combustion to pollution by airborne particles in urban and non-urban environments*, Commonwealth of Australia Energy Research and Development Corporation.

Jimoda, L.A. (2012). 'Effects of particulate matter on human health, the ecosystem, climate and materials: a review', *Facta universitatis-series: Working and Living Environmental Protection*, 9, pp. 27-44.

Franek, W., DeRose, P.E.M.L. (2003). *Principles and Practices of Air Pollution Control: Student Manual*, United States Environmental Protection Agency, Environmental Research Center.

Chow, J.C., Watson, J.G. (1998). *Guideline on speciated particulate monitoring. Report prepared for US Environmental Protection Agency*, Research Triangle Park, NC, by Desert Research Institute, Reno, NV.

Mukherjee, A., Agrawal, M. (2017). 'World air particulate matter: sources, distribution and health effects', *Environmental Chemistry Letters*, 15, pp. 283-309.

Ozaki, H., Ichise, H., Kitaura, E., Yaginuma, Y., Yoda, M., Kuno, K., Watanabe, I. (2019). 'Immutable heavy metal pollution before and after change in industrial waste treatment procedure', *Scientific reports* 9, pp. 1-12.

Ubavin, D., Agarski, B., Maodus, N., Stanislavljevic, N., Budak, I. (2018). 'A model for prioritizing landfills for remediation and closure: a case study in Serbia', *Integrated Environmental Assessment and Management*, 14, pp. 105-119.

SEPA (2005). *Creation of a national database on landfills in the territory of the Republic of Serbia*, Environmental Protection Agency of the Republic of Serbia.

SEPA (2021). *Waste Management in the Republic of Serbia in the period 2011-2020*, Environmental Protection Agency of the Republic of Serbia.

Macklin, Y., Kibble, A., Pollitt, F. (2011). *Impact on Health from Emissions from Landfill Sites: Advice from the Health Protection Agency*, Centre for Radiation, Chemical and Environmental Hazards.

Jia, Q., Huang, Y., Al-Ansari, N., Knutsson, S. (2013). 'Dust emissions from landfill deposition: a case study in Malmberget mine, Sweden', *Journal of Earth Sciences and Geotechnical Engineering*, 3, pp. 25-34.

Kovačević, R.M. (2016). *Content and composition of respirable particles in the urban environment of the city of Bor*, Phd thesis, Faculty of Chemistry, University of Belgrade, Belgrade.

Chalvatzaki, E., Glytsos, T., Lazaridis, M. (2015). 'A methodology for the determination of fugitive dust emissions from landfill sites', *International journal of environmental health research*, 25, pp. 551-569.

EPA (2006a). *Emission factor documentation For AP-42, section 1322, unpaved roads, final report*, U.S. Environmental Protection Agency, Midwest Research Institute, Kansas City.

EPA (2006b). *AP-42, CH 13.2.5: Industrial Wind Erosion*, U.S. Environmental Protection Agency, Washington, DC, USA.

## BIOGRAPHY of the first author

**Una Marčeta** was born in Zrenjanin, Serbia, in 1990.

She received a diploma in environmental engineering and she is a PhD student at the Faculty of Technical Sciences, University of Novi Sad. She is currently working as a Teaching Assistant at the Technical Faculty "Mihailo Pupin" Zrenjanin, University of Novi Sad





VESNA ŽIKIĆ<sup>1</sup>

<sup>1</sup>Ca' Foscari University of Venice,  
Italy

<sup>1</sup>vesnazikic@gmail.com  
975348@stud.unive.it

## INTEGRATED ASSESSMENT MODELS IN MODELLING THE WATER-ENERGY- FOOD NEXUS IN SPACE AND TIME

**Abstract:** *This paper discusses the Water-Energy-Food nexus (WEF), its interlinkages, and the understanding of its complexity and inter-relations. The study analyses Integrated Assessment Models (IAMs), which are designed to be applied to the WEF nexus and its temporal and spatial scale. The aim of the paper is to present and analyse the IAMs that mainly include the WEF nexus in order to find the most applicable/appropriate integrated assessment model for managing this complex nexus and to analyse spatial and temporal dimensions of IAMs for the WEF nexus. It is necessary to develop new models that include all components of WEF, helps in understanding processes in time and space and are applicable from local to global scale.*

**Key words:** integrated assessment (IA), integrated models (IM), integrated assessment models (IAMs), water-energy-food (WEF) nexus, water-energy-food-ecosystem (WEFE) nexus, framework, spatial and temporal dimension

### INTRODUCTION

There is strong interconnection in WEF nexus as water is needed for energy production, energy is necessary for water extraction and distribution, while water and food treatment require energy and water. Considering water, energy and food as the most important resources, the Water-Energy-Food (WEF) nexus emerged from the Bonn 2011 Nexus Conference, called "The Water, Energy and Food Security Nexus – Solutions for the Green Economy", as a preparation for the Rio +20 UN conference on Sustainable Development and as a promotion of the Green Economy concept (Federal Ministry for the Environment, Nature Conservation and Nuclear Safety, Federal Ministry for Economic Cooperation and Development and OOSKANews, 2011) [1]. Before 2011, the concept had been mostly referred to as the water-energy (WE) nexus in hydrology, starting from the mid-1990s. Even some authors (Newell, Goldstein and Foster, 2019) think that the WEF nexus has existed for about 40 years. Many international organizations started to stress the importance of the WEF nexus from 2011 and the Bonn Conference, such as: Stockholm Environment Institute (SEI) (stressing the importance of working on the WEF nexus will help combat climate change and move toward green economy) (Hoff, 2011), Joint Research Centre (JRC), Food and Agriculture Organization of the United Nations (FAO), International Institute for Sustainable Development (IISD) (Bizikova et al., 2013), and the United Nations Economic Commission for Europe (UNECE) (WEFE nexus – Task Force on

the Water-Food-Energy-Ecosystem Nexus) (UNECE, 2013). The WEF nexus also became the basis for achieving Sustainable Development Goals (SDGs).

After an online search using the key words for the water, energy, and food nexus in various combinations (*water-energy-food; water AND energy AND food AND nexus*), it seems that the nexus became very 'popular', and attracted interest among researchers after the Bonn Conference, with an increasing number of papers written from 2012 to 2020 (the Bonn conference was held in November 2011). Online searches yielded 5, 9, 17, 33, 98, 129, 169, 250, 281 and 128 papers from 2011 to 2020, respectively (key words: *water AND energy AND food AND nexus*) (Figure 1), while the key words *water-energy-food nexus* appeared zero times in the 2011 search and started to appear only from 2012 to 2020 – 1, 4, 9, 43, 47, 58, 97, 137 and 57 papers, respectively (Figure 2).

Many researchers (Shannak, Mabrey and Vittorio, 2018; Zhang *et al.*, 2018; Simpson and Jewitt, 2019) also performed comprehensive analyses of papers from Scopus, Web of Science (WOS), Science Direct and other databases, analysing frameworks, methodologies and use of the WEF nexus, and noticed a growing number of papers concerning the nexus in recent years. During the search it was noticed that the papers which appeared for the *water AND energy AND food* search are more related to the water-energy or the water-food nexus than the papers found searching for *water-energy-food nexus*.

In addition to the WEF, scholarly interest also grew for other nexuses in the previous years, such as: WEF-Land, Water-Energy-Food-Environment (WEFE), Water-Energy-Food-Ecosystem (WEFE) (JRC, 2019; UNECE; (Karabulut et al., 2016)) , Food-Energy-Water (FEW) (Newell, Goldstein and Foster, 2019), some nexuses that include land and soil, and so on (Smajgl, Ward and Pluschke, 2016).

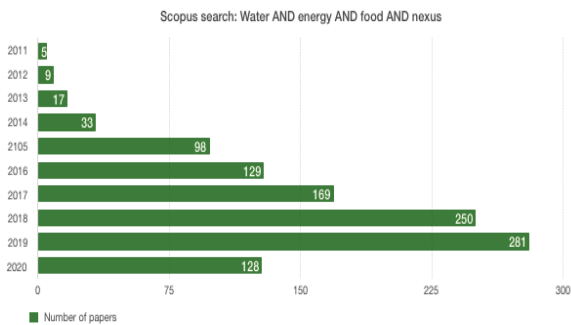


Figure 1. Scopus search of water energy food nexus

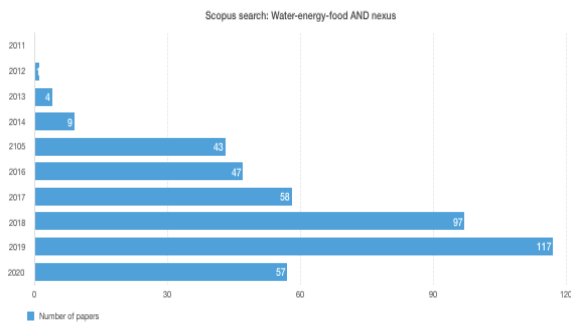


Figure 2. Scopus search of water-energy-food nexus

Growing interest in the WEF nexus is also driven by the difficulties to manage these resources, as different institutions, laws and rules deal with the WEF nexus issues, but the issues are interdependent and interconnected and have to be considered together in a comprehensive way (Shannak, Mabrey and Vittorio, 2018)) . In order to remove the institutional and legal barriers of WEF governance, it is very important to work on cross-sector partnerships and connections among the WEF institutions (Olawuyi, 2020)). There is still limited understanding of how to deal with the complex WEF relationships and interconnections and this concept is still not recognized in many countries (Gain, Giupponi and Benson, 2015; Sarkodie and Owusu, 2020).

The Integrated Assessment Society (TIAS) defines **Integrated Assessment (IA)** as “the scientific ‘meta-discipline’ that integrates knowledge about a problem domain and makes it available for societal learning and decision-making processes” (Giupponi et al., 2013).

Integrated Modelling (IM) started in the 1970s with the development of WORLD3 model in the report by the Club of Rome, “Limits to Growth”. Integrated Assessment Models (IAMs) are cost-benefit economic

models (tools) that emerged in recent years as a necessity for integrated environmental assessment and modelling in order to better understand the complex processes and connections between the human and the natural system. IAMs could also be local or regional models, unlike climate models, which are mainly global (Parker et al., 2002)) . IAMs’ complexity makes them look like black boxes and very difficult to understand and use, which is why some researchers propose that they be made simpler, like simulation games, in order to be easier to use by the end users (Giupponi et al., 2013)) .

There is a noticeable growth of the IAMs that are supposed to analyse the WEF nexus, but most of them are still related to the water-energy nexus, the water-food nexus, or the water-soil nexus.

Some authors (Hülsmann et al., 2019)) consider the WEF nexus rooted in Integrated Water Resources Management (IWRM) as IWRM deals with some of the nexus concepts.

## MATERIAL AND METHODS

The first IA models for the WEF nexus were developed using the methodology for watershed management (Shannak, Mabrey and Vittorio, 2018)) . Various models were developed later and since 2011, numerous studies have been conducted and WEF IA models developed (Wicaksono, Jeong and Kang, 2019)) . To have a better understanding of the models, the authors performed comprehensive research of the existing models, taking into consideration only the models that have the WEF nexus as a basic element. Agent Based Modelling has been proposed by many authors (Hoolohan et al., 2018) as it uses the bottom-up approach and could be used to involve stakeholders in the modelling. It can also disaggregate systems in individual components and can thus model even complex, nonlinear systems.

This section analyses IAMs for the WEF nexus, specifically the involvement of the spatial and temporal scales in particular IAMs. The following IAMs were analysed:

### CLEWs

Climate, Land (Food), Energy and Water strategies (CLEWs) is the framework that integrates existing tools and allows the interaction between interconnecting sectors (Martinez-Hernandez, Leach and Yang, 2017; Howells, 2018). CLEWs framework can be used in different geographical (urban, national, regional or global) scales and it has been applied in different case studies in different scales (New York, Burkina Faso, Mauritius, Punjab (India) and Uganda).

### WEAP-LEAP

The Stockholm Environmental Institute (SEI) developed the Water Evaluation and Planning (WEAP)

model for balancing water management. The model is also used for climate change adaptation planning. The Long-range Energy Alternatives Planning (LEAP) model integrates energy and greenhouse gas emission (GHG) mitigation planning. Individually, both models integrate different issues but the SEI integrated WEAP and LEAP and together they can model water and energy systems and climate change mitigation (Stephan et al., 2018) [1].

### MuSIASEM

The multi-scale integrated analysis of societal and ecosystem metabolism (MuSIASEM) focuses on multi-level socio-economic analysis in relation to the existence of ecological constraints. MuSIASEM simulates the WEF nexus with consideration of external components such as land, economy, human capital, ecosystem, greenhouse gas emissions and land use (Giampietro, Mayumi and Ramos-Martin, 2009) [2].

### WEF Nexus Tool 2.0

The Water-Energy-Food (WEF) Nexus Tool 2.0 was developed by Bassel T. Daher for his MSE degree at Purdue University. This tool was applied to a case study in Qatar, and it is still not possible to use it for other countries (Daher, Mohtar, 2015) [3].

### NexSym

The Nexus Simulation System (NexSym) is a tool that simulates the WEF nexus and technological and ecological processes on a local scale. NexSym simulates synergistic interactions between subsystems and analyses the level of resource sufficiency and maintenance of ecosystem capacities to meet the demands of a local population and enable nexus analytics at the component, nexus, and local system levels (Martinez-Hernandez, Leach and Yang, 2017) [4].

### WEFSiM/WEFSiM-opt

The Water-Energy-Food Nexus Simulation (WEFSiM) was developed by South Korean researchers as national-scale model that quantifies and evaluates the interconnections between the water, energy, and food sectors. WEFSiM uses a genetic algorithm (GA) and can use various pieces of information about water, energy and food sectors, but also considers population, socioeconomic and climate data. WEFSiM was later optimized (WEFSiM-opt) and both models were developed to maximize the User Reliability Index (URI) for water, energy and food sectors (Wicaksono, Jeong and Kang, 2019). WEFSiM-opt is used for optimising the single-objective genetic algorithm (SOGA) and adding the multi-objective optimization algorithm (MOGA). The two optimization algorithms (SOGA and MOGA) help maximise the reliability of resources (Wicaksono, Jeong and Kang, 2019) [5].

### SIM4NEXUS

The Sustainable Integrated Management FOR the NEXUS of water-land-food-energy-climate for a resource-efficient Europe (SIM4NEXUS, www.sim4nexus.eu) model is a result of the same project developed from EU Horizon 2020 funds in 2017. SIM4NEXUS include various models: E3ME, linked to FTT; Magnet; CAPRI; IMAGE and GLOBIO; OSeMOSYS; SWIM; and MAgPIE-LPJmL (Fazekas, Alexandri and Pollitt, 2017).

## RESULTS

Table 1 shows all of the previously mentioned Integrated Assessment Models and tools for the WEF nexus, analysed across various characteristics.

**Table 1.** IAMs for the WEF nexus

Model/Tool	Spatial and temporal dimension	System breadth	Developer/year of development	Geographic scale	Focus
CLEWS	- AEZ model for spatial analysis - Temporal analysis not clear	Climate, Land, Energy and Water	KTH, 2013	Global/National/regional/local	- Energy intensity for water and food production not defined
WEAP-LEAP	- Spatial dimension in meeting water demand for residential and agricultural sectors - Temporal dimensions included	Water-energy nexus	SEI, 2013	Watershed	- Food sector defined as part of the water demand - Energy issue not included

<b>MuSIASEM</b>	- No spatial and temporal dimension	WEF nexus components, Land, Economy, Human capital and Ecosystems	FAO, 2013	National or sub-national level	- Focus on multi-level socio-economic analysis - Simulates the WEF nexus with consideration of external components such as land, economy, human capital, ecosystem, greenhouse gas emissions, and land use
<b>WEF Nexus Tool 2.0</b>	- Spatial and temporal scale not included	WEF nexus (focus on food)	Bassel T. Daher & Dr Rabi H. Mohtar, 2013	National (Qatar)	- Simulates the requirements of water, energy, and farmland to support self-sufficiency of food products but provides limited feedback analysis between resources
<b>WEFSim</b>	- Not clear	WEF nexus	Kyung Here University, South Korea, 2018	National	- Feedback analysis among the resources is realized based on the concepts of “actual availability” and “indirect demand”
<b>WEFSim-Opt</b>	- Not clear	WEF nexus	Kyung Here University, South Korea, 2019		- SOGA & MOGA - Maximises the URI of water, energy, and food and the total reliability index (RI <sub>tot</sub> )
<b>NexSym</b>	- Spatial scale: land re-development available, which includes residential, industrial and ecosystem land - Temporal: 50 years	WEF nexus, waste treatment, ecosystem, consumption, other components of local system	2016	Local scale	- More comprehensive analysis - Simulates synergistic interactions between subsystems and analyses the level of resource sufficiency and maintenance of ecosystem capacities to meet the demands of a local population  - Enables nexus analytics at the component, nexus, and local system levels
<b>SIM4NEXUS</b>	- Various SIM4NeXUS models developed for various spatial scales - Temporal scale not clear	WEF nexus, land and climate	2017	Global/National/regional/local	- Focus is not on climate change, but climate change could intensify pressures across the nexus (e.g. through reduced crop yields or less reliable rainfall patterns)

**DISCUSSION**

The previous section analysed eight different IAMs that include the WEF nexus as a prerequisite. Some of them also include other components in the nexus, such as: land, climate, ecosystem, waste, economy or human capital. Despite the numerous IAMs for the WEF nexus, most of them do not clearly define the spatial or

the temporal scale, while others only include one of the scales. Only two models include both the temporal and the spatial scale: WEAP/LEAP and NexSym. Integration of spatial and temporal dimensions in the IAMs could provide a better understanding of the complexity of the WEF nexus and thus ensure better policies for achieving SDGs. Spatial and temporal dimensions of the models are also very important for understanding resource availability and accessibility as

natural resources are subject to great change over space and time (Shannak, Mabrey and Vittorio, 2018)

Previous analyses have shown that very few models use an interdisciplinary approach and political, social and economic dimensions are usually not included. Flexibility of the IAMs in the geographical scale is also very important, as most of the models are applicable only on the local or national level and only CLEWS and SIM4NEXUS could be applied at the local, regional, national or global scale.

## CONCLUSIONS

Modelling of the WEF nexus is a very challenging issue due to its complexity and dynamics. Nevertheless, the spatial and temporal dimensions should be included in IAMs for better understanding of the processes in time and space and for a better decision-making process in order to achieve SDGs. There is indeed a need for more sophisticated models that will support planning and regulatory policy processes and be applicable on different scales from the local to the global level. As most IAMs do not include all the dimensions of the WEF nexus, there is a need for models that will include all three dimensions of the WEF nexus and that will use transdisciplinary approaches in analysing the nexus, as well as political, social and economic issues. IAMs are very complicated for end users, so they need to be simplified in order to be useful and easy to use for decision makers.

## REFERENCES:

- Bizikova, L. *et al.* (2013) 'The Water-energy-food Security Nexus: Towards a Practical Planning and Decision-support Framework for Landscape Investment and Risk Management', *International Institute for Sustainable Development*, (February), p. 28. Available at: [http://www.iisd.org/sites/default/files/pdf/2013/wef\\_nexus\\_2\\_013.pdf](http://www.iisd.org/sites/default/files/pdf/2013/wef_nexus_2_013.pdf).
- Fazekas, D., Alexandri, E. and Pollitt, H. (2017) 'D1.3: Sim4Nexus – Review of Thematic Models and Their Capacity to Address the Nexus and Policy Domains', (689150), pp. 1–46.
- Federal Ministry for the Environment, Nature Conservation and Nuclear Safety, Federal Ministry for Economic Cooperation and Development and OOSKANews (2011) 'The Water, Energy and Food Security Nexus - Solutions for the Green Economy. Conference Synopsis', *The Water, Energy and Food Security Nexus - Solutions for the Green Economy*, (November), p. 28.
- Gain, A. K., Giupponi, C. and Benson, D. (2015) 'The water-energy-food (WEF) security nexus: the policy perspective of Bangladesh', *Water International*, 40(5–6), pp. 895–910. doi: 10.1080/02508060.2015.1087616.
- Giampietro, M., Mayumi, K. and Ramos-Martin, J. (2009) 'Multi-scale integrated analysis of societal and ecosystem metabolism (MuSIASEM): Theoretical concepts and basic rationale', *Energy*, 34(3), pp. 313–322. doi: 10.1016/j.energy.2008.07.020.
- Giupponi, C. *et al.* (2013) 'Innovative approaches to integrated global change modelling', *Environmental Modelling and Software*. Elsevier Ltd, 44, pp. 1–9. doi: 10.1016/j.envsoft.2013.01.013.
- Hoff, H. (2011) 'Understanding the Nexus. Background paper for the Bonn2011 Nexus Conference', *Stockholm Environment Institute*, (November), pp. 1–52.
- Hoolohan, C. *et al.* (2018) 'Engaging stakeholders in research to address water-energy-food (WEF) nexus challenges', *Sustainability Science*. Springer Japan, 13(5), pp. 1415–1426. doi: 10.1007/s11625-018-0552-7.
- Howells, M. (2018) 'Climate, Land, Energy and Water strategies (CLEWs)'.
- Hülsmann, S. *et al.* (2019) 'Integrated modelling and management of water resources: the ecosystem perspective on the nexus approach', *Current Opinion in Environmental Sustainability*, 40, pp. 14–20. doi: 10.1016/j.cosust.2019.07.003.
- Karabulut, A. *et al.* (2016) 'Mapping water provisioning services to support the ecosystem-water-food-energy nexus in the Danube river basin', *Ecosystem Services*, 17(2016), pp. 278–292. doi: 10.1016/j.ecoser.2015.08.002.
- Martinez-Hernandez, E., Leach, M. and Yang, A. (2017) 'Understanding water-energy-food and ecosystem interactions using the nexus simulation tool NexSym', *Applied Energy*. Elsevier, 206(June), pp. 1009–1021. doi: 10.1016/j.apenergy.2017.09.022.
- Newell, J. P., Goldstein, B. and Foster, A. (2019) 'A 40-year review of food-energy-water nexus literature and its application to the urban scale', *Environmental Research Letters*. IOP Publishing, 14(7). doi: 10.1088/1748-9326/ab0767.
- Olawuyi, D. (2020) 'Sustainable development and the water-energy-food nexus: Legal challenges and emerging solutions', *Environmental Science and Policy*. Elsevier, 103(July 2019), pp. 1–9. doi: 10.1016/j.envsci.2019.10.009.
- Parker, P. *et al.* (2002) 'Progress in integrated assessment and modelling1A Summary of a workshop on Integrated Assessment and Modelling, held at EcoSummit 2000: Integrating the Sciences, Halifax, June 18–22, 2000. See Costanza and Jorgensen (2001) for a further report on Ecosummit', *Environmental Modelling & Software*, 17(3), pp. 209–217. doi: 10.1016/s1364-8152(01)00059-7.
- Sarkodie, S. A. and Owusu, P. A. (2020) 'Bibliometric analysis of water-energy-food nexus: Sustainability assessment of renewable energy', *Current Opinion in Environmental Science and Health*. Elsevier Ltd, 13(November), pp. 29–34. doi: 10.1016/j.coesh.2019.10.008.
- Shannak, S., Mabrey, D. and Vittorio, M. (2018) 'Moving from theory to practice in the water-energy-food nexus: An evaluation of existing models and frameworks', *Water-Energy Nexus*. KeAi Communications Co., Ltd, 1(1), pp. 17–25. doi: 10.1016/j.wen.2018.04.001.
- Simpson, G. B. and Jewitt, G. P. W. (2019) 'The development of the water-energy-food nexus as a framework for achieving resource security: A review', *Frontiers in Environmental Science*, 7(FEB), pp. 1–9. doi: 10.3389/fenvs.2019.00008.



Smajgl, A., Ward, J. and Pluschke, L. (2016) 'The water-food-energy Nexus - Realising a new paradigm', *Journal of Hydrology*, 533, pp. 533–540. doi: 10.1016/j.jhydrol.2015.12.033.

Stephan, R. M. *et al.* (2018) 'Water–energy–food nexus: a platform for implementing the Sustainable Development Goals', *Water International*. Routledge, 43(3), pp. 472–479. doi: 10.1080/02508060.2018.1446581.

Wicaksono, A., Jeong, G. and Kang, D. (2019) 'Water-energy-food nexus simulation: An optimization approach for resource security', *Water (Switzerland)*, 11(4). doi: 10.3390/w11040667.

Zhang, C. *et al.* (2018) 'Water-energy-food nexus: Concepts, questions and methodologies', *Journal of Cleaner Production*, 195(May), pp. 625–639. doi: 10.1016/j.jclepro.2018.05.194.

## **BIOGRAPHY of the first author**

**Vesna Žikić** was born in Niš, Serbia, in 1973.

She received her B.Sc. and M.Sc. degree in Environmental Engineering at the Faculty of Occupational Safety in Niš. Her main areas of research include climate change, mitigation and adaptation, sustainable development, life cycle assessment (LCA), life cycle management (LGM), risk assessment, and nature-based solutions.

She is currently a student of master studies in Science and Management of Climate Change at Ca' Foscari University of Venice and a PhD student at the Faculty of Occupational Safety in Niš.



VESNA MILTOJEVIĆ<sup>1</sup>  
IVANA ILIĆ KRSTIĆ<sup>2</sup>

<sup>1,2</sup>University of Niš,  
Faculty of Occupational Safety

<sup>1</sup>vesna.miltojevic@znrfak.ni.ac.rs

<sup>2</sup>ivana.ilic@znrfak.ni.ac.rs

## ECOLOGICAL AWARENESS OF FEMALE FARMERS AND CLIMATE CHANGE ADAPTATION – A CASE STUDY

**Abstract:** *Agricultural production and climate are inseparable and interdependent. Even though the negative impact of climate change on agriculture is most often emphasized, it needs to be noted that agriculture can also negatively affect climate.*

*The aim of this paper is to determine the level of ecological awareness among female farmers, their perception of the impact of agricultural production on climate change, and their attitudes about the efficiency of climate change adaptation measures. The paper also focuses on the implementation of such measures aimed at reducing the negative environmental and climate change impact of farming and the losses in agricultural production due to climate change.*

*A survey based on a specially designed questionnaire was used to collect the data. Ecological awareness was measured using the New Ecological Paradigm scale on a sample of 132 women from the Municipality of Svrlijig, Nišava District, Serbia. The obtained data indicate that the majority of respondents possess a partially developed ecological awareness (43.94%) or latent ecological awareness. A connection was established between age and the level of ecological awareness and between the level of education and the level of ecological awareness. The majority of respondents are aware of the negative environmental and climate change impact of certain agricultural activities. Specifically, the survey found a strong influence of the level of ecological awareness on the attitudes about the burning of pesticide packaging and a medium influence on the attitudes about using pesticides without consulting an expert and the attitudes about the environmental and climate change impact of agricultural product transport. The obtained results also show that the majority of respondents correctly assess the efficiency of specific climate change adaptation measures; however, only a small percentage of them actually take such measures.*

*The results can be used by the local community to propose climate change adaptation measures that would take into account the position, place, and role of women.*

**Key words:** ecological awareness, climate change, female farmers, adaptation measures.

## INTRODUCTION

Modern civilization is faced with one of the most prominent current issues – climate change – which is directly associated with the greenhouse effect. Even though the energy sector has been identified as the main source of greenhouse gases (carbon dioxide, methane chlorofluorocarbons, and nitrous oxide), other activities, such as agricultural production, transport, and the like should not be disregarded. Climate change causes numerous problems in the ecosphere and the sociosphere while the negative effects keep multiplying.

Agriculture is the economic activity that is affected by climate change the most. Temperature increase, prolonged dry periods, and heavy precipitation events at an inopportune time negatively impact agricultural production. However, the negative impact of agriculture on climate change should also be considered. Modern industrial agriculture significantly contributes to climate change by releasing large quantities of greenhouse gases. According to the Intergovernmental Panel on Climate Change, around one-quarter of greenhouse gases are emitted because of agricultural production. Garnett states that during production, processing, transport, storage, purchase, and consumption, agriculture contributes to the global

greenhouse gas emissions from 15% to 30% (Garnett, 2008).

When climate conditions change, it is important to resort to specific agricultural practices in order to reduce the negative impact of climate change on production and cut the producer costs on the one hand and reduce the negative environmental and climate change impact on the other hand.

Activities of women involved in agricultural production include the production of crops, animal husbandry, preparation of agricultural products for personal use or trade, selling of products, and marketing (Ilić Krstić, 2020). These activities can considerably disrupt the ecological balance and alter the climate but can also protect against or mitigate the negative impact of agriculture on climate change. In addition to their economic and general social status, the influence of women on the implementation of agricultural practices and pro-ecological behaviour aimed at climate change adaptation also depends on their level of ecological awareness (Despotović, 2021). Women's knowledge about the connection of their activity to the environment and its environmental and climate change impact, environmental valuation, and an appropriate perception of the place and role of humans in the environment are also important aspects.

This paper presents the results of a more extensive study, which, among others, included the following objectives: (1) to examine the level of ecological awareness among female farmers; (2) to examine the relationship between the level of ecological awareness and the environmental and climate change impact of specific agricultural activities; and (3) to examine the relationship between the level of ecological awareness and estimated efficiencies of specific adaptation measures and of their implementation.

## **MATERIALS AND METHODS**

A special questionnaire was designed for the purpose of this study, with questions divided into five batteries. The first battery of questions refers to the demographic characteristics of the respondents, the second refers to the ownership status of the agricultural holding (farm), the third to the level of ecological awareness, the fourth to the relationship between agricultural production and climate change, and the fifth battery refers to how well-informed the local community is and what it does to fight climate change.

The level of ecological awareness was measured using the New Ecological Paradigm (NEP) scale containing 15 items [4] and based on a five-point Likert scale. The reliability of the scale expressed as Cronbach's  $\alpha$  is 0.86, which indicates that the scale is valid. The sum score for each respondent ranges from 15 to 75. Based on previous studies, the score range from 15 to 47 is indicative of poorly developed ecological awareness, from 48 to 60 of partially developed ecological awareness, and from 61 to 75 of highly developed ecological awareness, or, in Welsch's terms: of anti-

ecological, mid-ecological, and pro-ecological paradigm, respectively (Welsch, 2011).

The impact of agricultural production on climate change was investigated via responses assessing specific agricultural activities, from production to product placement, on a five-point Likert scale. Considering the indications by the Intergovernmental Panel on Climate Change and the Global Carbon Project, and findings of scientific and professional studies on the negative impact of specific agricultural activities on the climate, the present study focuses on the attitudes about how the use of artificial fertilizers and pesticides, the burning of crop residue and pesticide packaging, the use of machinery, and the transport of agricultural products affect the climate.

A three-point scale was used for questions about the production damage caused by climate change and the efficiency of proposed measures against climate change.

The study was conducted from October 2021 to February 2022 under difficult conditions owing to the COVID-19 pandemic. The random sample comprises 132 female respondents from the Nišava District, specifically from the Municipality of Svrlijig, because agricultural land covers 65.5% of the total surface area of the municipality. The agricultural land prevalently includes pastures and meadows with a surface area of 8,382.03 hectares (ha), followed by ploughland and gardens (6,170 ha), orchards (672.15 ha), and vineyards (39.44 ha). In Svrlijig, 7,964 individuals are involved in farming activities [6]. According to the agricultural census from 2012, there are 3,316 registered agricultural holdings, almost all of which (99.73%) are family-owned farms, predominantly headed by male family members (82.13%). It is estimated that the municipality will experience a 1.7°C increase in mean annual temperature by 2040. At the same time, it is expected that the average annual precipitation will decrease by up to 13% and that the drought index will increase (Vranić, 2018), indicating significant changes in climatic conditions.

The results were processed using the methods of descriptive statistics (frequency, percentage, mean value, and standard deviation). Analysis of variance (ANOVA) with LSD and Tukey's HSD was used to determine the significance of differences, whereas eta squared was used to determine the influence between the groups.

Data processing was conducted using SPSS 20.0 software.

## **RESULTS**

Out of 132 female respondents, 33.3% are aged 18 to 35, 53% are aged 36 to 65, and 13.6% are over 65. Most of them have completed secondary education (48.5%), followed by higher education (33.3%), and primary education (18.2%). With regard to surface area, 62.1% are engaged in farming on a 5- to 10-ha area, 36.4% on a 5-ha area, and only 1.5% on an area

larger than 10 ha. Of the total number of respondents, only 17.42% own farming land regardless of the surface area they farm. However, among the respondents who farm on areas larger than 5 ha (N=84), slightly more of them own that land (27.38%), which is a more favourable percentage than the one included in the census data. Most respondents exclusively practice outdoor olericulture, 57.7% (considerably fewer practice it inside a greenhouse (18.2%)), followed by pomology (37.9%), while fewer than 10% are exclusively involved in viticulture or other types of production (medicinal plants, nursery production, etc.). Arable crop farming and olericulture is practiced by 51.5% of the respondents, while 36.36% are involved in greenhouse farming and animal husbandry.

### Level of ecological awareness among female farmers

Based on the obtained results, the lowest NEP scale value is 30 and the highest is 75. The average NEP scale value is 51.15 or, if a result is represented on a five-point scale, the average value is 3.41, which suggests that most respondents have a partially developed ecological awareness.

Although partial ecological awareness is dominant, there are certain differences depending on age (Table 1). It was observed that the percentage of respondents with highly developed ecological awareness increases with age. However, the differences in mean values are negligible and the eta squared ( $\eta^2$ ) of 0.018 indicates a weak influence of age on the level of ecological awareness. These results are opposed to the previous studies, one of them conducted on the general population, where younger respondents showed a higher level of ecological awareness than their seniors (Thomson, 2013), and another conducted on agricultural producers in Vojvodina, where no differences were observed between the younger and the older respondents (Despotović, 2021).

**Table 1.** Age and the level of ecological awareness

Age	Ecological awareness			Σ
	Poor	Partial	High	
18-35	20.45%	59.10%	20.45%	100%
36-65	42.90%	35.70%	21.40%	100%
> 65	38.90%	38.90%	22.20%	100%
Total	34.84%	43.94%	21.22%	100%

Based on the obtained data, a connection was found between the level of education and the level of ecological awareness. The respondents with primary and secondary education exhibited poor ecological awareness, while those with higher education exhibited partially developed ecological awareness. It was also determined that the percentage of respondents with poor ecological awareness decreases and that of respondents with highly-developed ecological awareness increases as their education level increases (Table 2). The obtained results correspond to those obtained previously on the general population

(Thomson, 2013), but not to those obtained on the sample of agricultural producers in Vojvodina, where no differences were found in relation to the level of education (Despotović, 2021).

**Table 2.** Education level and the level of ecological awareness

Education	Ecological awareness			Σ
	Poor	Partial	High	
Primary	45.8%	41.7%	12.5%	100%
Secondary	42.2%	40.6%	17.2%	100%
Higher	18.2%	50%	31.8%	100%
Total	34.84%	43.94%	21.22%	100%

The obtained values [primary (group 1): M=1.67, SD=0.702; secondary (group 2): M=1.75, SD=0.735; higher (group 3): M=2.14, SD=0.72] indicate differences between the groups and  $\eta^2=0.070$  indicates a moderate influence of education level on the level of ecological awareness. The ANOVA test (F=4.878, df=2) determined the significance Sig. 0.009, while subsequent testing revealed differences between the respondents from groups 1 and 2 (Sig. 0.011) and groups 1 and 3 (Sig. 0.007).

### Ecological awareness and assessment of agricultural impact on climate change

Over a half of the respondents, 56.8% and 55.3%, agree that the burning of pesticide packaging and the use of pesticides without consulting an expert negatively affect the environment. Other activities that the respondents saw as negatively affecting the environment and climate change include the burning of crop residue (47.7%), the use of artificial fertilizers without consulting an expert (37.2%), transport of agricultural products (34.1%), and the use of machinery (only 22%).

Respondents with more developed ecological awareness properly assessed the impact of specific agricultural activities, from production to transport, on the environment and climate change. Minimal differences in mean values, standard deviation, and eta squared showed that the level of ecological awareness has a weak influence on the attitudes about the use of artificial fertilizers without consulting an expert, the burning of crop residue, and the use of machinery. The level of ecological awareness has a moderate influence on the attitudes about the use of pesticides without consulting an expert and transport of agricultural products and a strong influence on the attitude about the burning of pesticide packaging.

Most respondents with a low level of ecological awareness (52.2%) disagree with the attitude that the use of artificial fertilizers without consulting an expert affects climate change, while 43.1% of the respondents with partially developed ecological awareness neither agree nor disagree with this attitude. In contrast, most respondents with a high level of ecological awareness (57.2%) agree with this attitude. With regard to how

the use of artificial fertilizers without consulting an expert affects climate change, the ANOVA test showed that there are significant differences between the groups ( $F=3.538$ ,  $df=2$ , Sig. 0.032) and the post hoc tests revealed significant differences between the respondents with poor and partially developed ecological awareness (Sig. 0.026) and between those with poor and highly developed ecological awareness (Sig. 0.024).

Regardless of the level of ecological awareness, most respondents agree that the burning of crop residue negatively affects climate change, specifically 46.6% of those with poorly developed and as many as 75% of those with highly developed ecological awareness. Even though fewer respondents with partially developed ecological awareness agree with this attitude (36.2%), it is nonetheless a prevalent one in this group, as well. The ANOVA test established a significant difference ( $F=2.438$ ,  $df=2$ , Sig. 0.091) while the post hoc tests revealed a difference between the respondents with poor and highly developed ecological awareness (Sig. 0.030).

Similar data were obtained for the use of pesticides without consulting an expert. Respondents with poorly developed ecological awareness almost equally agree, disagree, or are undecided regarding the use of pesticides without consulting an expert (32.6%, 32.6%, and 34.8%), while the majority of those with partially and highly developed ecological awareness agree with this attitude (65.5% and 71.4%, respectively). This attitude showed an increasing trend of agreement as the level of ecological awareness increased. The ANOVA test showed that there are significant differences between the groups ( $F=6.268$ ,  $df=2$ , Sig. 0.003), while the post hoc tests revealed significant differences between the respondents with poor and partially developed ecological awareness (Sig. 0.001) and between those with poor and highly developed ecological awareness (Sig. 0.013).

The most significant influence of the level of ecological awareness was determined for the burning of pesticide packaging ( $F=12.667$ ,  $df=2$ , Sig. 0.000). Most respondents with poor ecological awareness (45.7%) disagree with this attitude, whereas most respondents with partially and highly developed ecological awareness agree with it (75.8% and 67.9%, respectively). Post hoc tests showed a difference between the respondents with poor and partially developed ecological awareness (Sig. 0.000) and between those with poor and highly developed ecological awareness (Sig. 0.005).

Regardless of the level of ecological awareness, most respondents stated that the use of machinery does not negatively affect climate change (45.6%, 50%, and 42.9%). The respondents similarly assessed the impact of transport of agricultural products. It is noteworthy that as many as 50% of the respondents with poor ecological awareness agree that such transport negatively affects climate change. In contrast,

considerably fewer respondents with partially and highly developed ecological awareness expressed agreement with this attitude (20.7% and 35.7%, respectively). The ANOVA test showed that there are significant differences between the groups ( $F=4.218$ ,  $df=2$ , Sig. 0.017), while the post hoc tests revealed significant differences between the respondents with poor and partially developed ecological awareness (Sig. 0.004).

### Ecological awareness, effects of climate change, and implementation of adaptation measures

The majority of the respondents are aware of the impact of climate change on their production. More than a half of them (52.3%) stated that they had suffered moderate consequences due to climate change, 25% that they had suffered significant consequences, and 22.7% that they had suffered no such consequences. The eta squared value did not indicate an influence of the level of ecological awareness on the assessment of damage due to climate change. Over 50% of the respondents believe that they suffered moderate consequences from drought, waterlogging, extremely high or low temperatures, reduced time for crop growth, postponement of harvest and fruit picking due to rotting, reduced yield, new invasive pests and diseases, and increased vulnerability to existing pests. Slightly fewer than 50% believe that moderate consequences are due to late-spring frosts, snow, hail, and soil erosion, while fewer than 40% included flooding.

Late-spring frosts, emergence of new pests, heavy winter snowfall, flooding, hail, and drought are listed as the causes of significant negative consequences of climate change for the respondents' agricultural production (Figure 1).

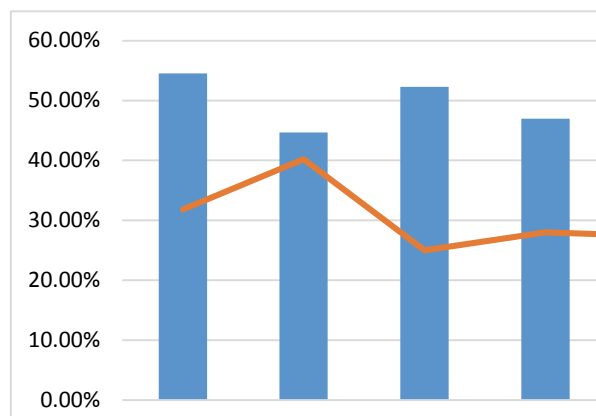


Figure 1. The most important causes of moderate and significant consequences of climate change

According to 86.30% of the respondents, emergence of new pests negatively affects production. Their emergence caused moderate negative effects according to 54.5% and significant negative effects according to 31.8% of the respondents. Implementation of agrotechnical measures and consultations with



agronomists is an efficient solution according to two-thirds of the respondents. However, only one-third of them actually implemented this measure. The eta squared of 0.036 indicates a weak influence of the level of ecological awareness on the implementation of this measure. Yet, unexpectedly, the measure is implemented the most by those respondents with low ecological awareness (45.7%), and the percentage only decreases as the level of ecological awareness increases – 24.1% of the respondents with partially developed and 17.9% with highly developed ecological awareness implement the measure.

According to 84.90% of the respondents, late-spring frosts cause negative effects (moderate 44.70% and significant 40.20%). Opting for crop species that start growing later is an efficient measure according to 71.20% of the respondents, but only 20.5% actually implement the measure, whereby the eta squared of 0.022 indicates a weak influence of the level of ecological awareness on the choice of this measure.

A high percentage of respondents (77.3%) stated that drought causes moderate (52.3%) and significant (25%) negative effects on their production. Over 65% of them listed the following measures as being efficient against droughts: placement of protective nets and covers to save water, growing crops with an irrigation system, increased efficiency when using water from existing irrigation systems, use of multi-purpose reservoirs for irrigation, use of drainage canals for irrigation, construction of small accumulation reservoirs on the property, and growing of crop species resilient to drought and heat. However, few respondents actually implement these measures (from 12.1% to 21.2%).

Regardless of the level of ecological awareness, most respondents believe that the placement of protective nets and covers to save water is a highly efficient measure. The eta squared of 0.138 indicates a strong influence of the level of ecological awareness on the assessment of the efficiency of this measure. As the level of ecological awareness increases, so does the number of respondents who consider the measure as significantly efficient – 52.2% respondents with a low level of ecological awareness, 84.5% with partial awareness, and as many as 89.3% with high awareness. Interestingly, only 12.1% actually implement the measure, the majority of which is comprised of respondents with low ecological awareness (7.6%), and significantly fewer of those with partial and high ecological awareness (2.3% each). Level of ecological awareness has a strong influence on the efficiency assessment of growing crops with an irrigation system ( $\eta^2=0.132$ ), but a weak influence on the implementation of this measure ( $\eta^2=0.043$ ). All respondents assess this measure as highly efficient regardless of their level of ecological awareness (low: 50%, partial: 82.8%, and high: 85.7%), with an observed trend of increased efficiency assessment as the level of ecological awareness increases. It is once again interesting that none of the respondents with partial and high ecological awareness implement the measure, while as

many as 43.5% with low ecological awareness do. Efficiency assessment for using water from existing irrigation systems depends on the level of ecological awareness, as confirmed by the eta squared of 0.201, but with a weak influence on implementation ( $\eta^2=0.011$ ). Once again, most respondents believe that the measure is highly efficient regardless of their level of ecological awareness (low: 45.7%, partial: 86.2%, and high: 89.3%), whereby most respondents with high ecological awareness assess the measure as highly efficient. Yet again, it is mostly implemented by the respondents with low ecological awareness (41.3%), which is considerably more than the other two categories (partial: 10.3% and high: 10.7%).

Similar results were obtained for the efficiency assessment of the use of drainage canals for irrigation. The eta squared of .156 indicates a strong influence of the level of ecological awareness on the efficiency assessment of this measure, but not on its implementation ( $\eta^2=0.003$ ). Most respondents believe that this is a significantly efficient measure, whereby a considerably higher percentage with partial and high ecological awareness assess the measure as efficient (low: 47.8%, partial: 81%, and high: 75%). Yet, it is the respondents with low ecological awareness that implement it the most (39.1%) compared to the other two categories (partial: 5.2% and high: 17.9%). Ecological awareness has a moderate influence on the attitudes regarding the efficiency of constructing small accumulation reservoirs on one's property ( $\eta^2=0.067$ ) and a weak influence on the implementation of this measure ( $\eta^2=0.046$ ). Higher percentage of respondents with highly developed ecological awareness consider this to be a significantly efficient measure (85.7%) compared to the other two categories (low: 50%, partial: 79.3%). The measure is implemented by 17.4% of the respondents with low, 1.7% with partial, and 35.7% with high ecological awareness. The eta squared of .026 indicates a weak influence of the level of ecological awareness on the efficiency assessment of using multi-purpose reservoirs for irrigation, but not on the actual implementation of the measure ( $\eta^2=0.003$ ). The same applies to the efficiency assessment and implementation of growing crop species resilient to drought and heat ( $\eta^2=0.011$ ,  $\eta^2=0.020$ ). Regardless of the level of ecological awareness, most respondents believe that the use of multi-purpose reservoirs for irrigation is a highly efficient measure (low: 67.4%, partial: 75.9%, and high: 78.6%), and the number of respondents who consider the measure as efficient increases with higher levels of ecological awareness. The measure is already being implemented prevalently by women with low ecological awareness (17.4%), followed by those with high (14.3%) and partially developed awareness (8.6%). The level of ecological awareness influences the efficiency assessment for the selection of crop species resilient to drought and heat (low: 58.7%, partial: 63.8%, high: 85.7%); however, regarding implementation, once again the respondents with low ecological awareness prevail (21.7%),

followed by those with partially developed (20.7%) and high awareness (14.3%).

According to 75% of the respondents, heavy winter snowfall causes moderate and significant damage (47% and 28%). Even though 68.9% believe that the installation of windbreaks, which prevent the formation of snow deposits and attenuate wind gusts, is an efficient measure, only 6.1% actually implement it. The eta squared of 0.018 indicates a weak influence of the level of ecological awareness on the efficiency assessment for this measure. Most respondents believe that the measure is highly efficient (low: 63%, partial: 69%, high: 78.6%) and there is a growing trend of assessing the measure as efficient as the level of ecological awareness increases. The influence of the level of ecological awareness on the implementation of this measure is weak ( $\eta^2=0.022$ ), as it is implemented by fewer than 10% of the respondents regardless of their level of ecological awareness, those with high awareness being prevalent (7.1%) and followed sequentially by those with lower levels of awareness (partial: 6.9%, low: 4.3%).

According to 75% of the respondents, hail causes moderate and significant damage to agricultural production (47.70% and 27.30%). As many as 89.4% believe that the placement of anti-hail nets is an efficient measure but only 15.9% implement it. The influence of the level of ecological awareness on both the efficiency assessment and the implementation of this measure is weak ( $\eta^2=0.016$ ,  $\eta^2=0.011$ ). Most respondents believe that the measure is highly efficient, with percentages increasing with the level of ecological awareness (low: 82.6%, partial: 91.4%, and high: 96.4%). Regardless of the fact that the respondents with highly developed ecological awareness assess the efficiency of the measure most adequately, only 3.6% actually implement it. Interestingly, it is implemented by 10.3% of the respondents with partially developed and as many as 30.4% with poorly developed ecological awareness.

Two thirds of the respondents (66.6%) see floods as the cause of moderate and significant damage (38.6% and 28%). More than 70% consider the construction of drainage systems, flood embankments, and restoration of vegetation and afforestation around arable plots as efficient measures, but few of them implement them (from 8.3% to 10.6%). The influence of the level of ecological awareness on the efficiency assessment of drainage system construction is weak ( $\eta^2=0.015$ ), even though most respondents think that the measure is highly efficient (low: 84.8%, partial: 72.4%, high: 85.7%). Few respondents implement it – only those with low and high ecological awareness (17.4% and 21.4%). The level of ecological awareness also has a weak influence on the efficiency assessment of raising flood embankments ( $\eta^2=0.045$ ) and has no influence on the implementation of this measure ( $\eta^2=0.001$ ). It is implemented by one-quarter of the respondents, regardless of their level of ecological awareness (low: 17.4%, partial: 1.7%, high: 7.1%). The level of

ecological awareness has another weak influence on the efficiency assessment of vegetation restoration and afforestation around arable plots as a measure to combat climate change ( $\eta^2=0.038$ ) as well as on its implementation ( $\eta^2=0.044$ ). Most respondents believe that this is a highly efficient measure (69.8%, 81%, and 85.7%), whereby the higher the level of awareness, the more efficient the measure is considered. Nevertheless, a significantly higher percentage of women with high ecological awareness already implement the measure (25%) compared to those with partially developed (3.4%) and low ecological awareness (6.5%).

## CONCLUSION

It was determined from the study results that the majority of surveyed female farmers possess partially developed ecological awareness and that pro-environmental behaviour is lacking. Overall, they adequately assess the negative environmental and climate change impact of specific aspects and are aware of the negative impact of climate change on agriculture and of the efficiency of adaptation measures; however, they do not implement such measures to a sufficient extent.

There are numerous potential causes of such deficient implementation of adaptation measures. One of the most likely is the traditional understanding of the place and role of women in agricultural production, usually associated with farm ownership and decision-making regarding production (Ilić Krstić, 2021). Regardless of the legislation protecting gender equality and shared marital property, men still prevalently own agricultural property (Plan razvoja opštine Svrlijig 2021-2028). Other reasons include poor information dissemination about the aid local self-governments provide for the implementation of certain adaptation measures and the notion of women as unimportant in the fight against climate change. Unfortunately, the Development Plan for the Municipality of Svrlijig from 2021 to 2028 contains no gender differentiation. The goals indeed include the fight against climate change, environmental protection, and agricultural development, but women are not recognized as a target group for education, land ownership status improvement, and subsidies (Plan razvoja opštine Svrlijig 2021-2028). The hope remains that the agricultural development strategy of this municipality will recognize the gender-specific aspects of agricultural production, including climate change adaptation measures.

## REFERENCES

- Despotović, J. Rodić, V. Bošnjak, D. Miltojević, V. (2021). 'The Impact of Demographic variables on the Farmers' Environmental Attitudes', *Agroekonomika*, Vol. 50, No. 90, pp. 53-63.
- Dunlap, E. R. Van Liere, D. K. Mertig, G. A. and Emmet, R. J. (2000). 'Measuring Endorsement of the New Ecological Paradigm: A Revised NEP Scale', *Journal of Social Issues*, Vol. 56, No. 3, pp. 425-442.

Garnett, T. (2008). *Cooking Up a Storm. Food, Greenhouse Gas Emissions and Our Changing Climate*, Centre for Environmental Strategy, University of Surrey, United Kingdom.

Ilić Krstić, I., Miltojević, V. (2021). 'Gender Perspective of Climate Change in the Republic of Serbia', *Facta Universitatis: Working and Living Environmental Protection*, Vol. 18, No. 3, pp. 129-141.

Ilić Krstić, I., Miltojević, V. (2020). 'Žene u poljoprivredi i adaptacija na klimatske promene' [Women in Agriculture and Climate Change Adaptation], *Svet rada*, vol. 17, br. 3, str. 295-304.

*Plan razvoja Opštine Svrljig 2021-2028 [Development Plan for the Municipality of Svrljig 2021-2028*, [online], available: <https://www.svrljig.rs/plan-razvoja-opstine-svrljig-2021-2028-godine/>

Thomson, J. (2013). *New Ecological Paradigm Survey 2008: Analysis of the NEP results*, Waikato Regional Council Technical Report 2013/11. [online], available: <https://www.waikatoregion.govt.nz/assets/PageFiles/26060/TR201311.pdf>

Vranić, P. D. (2018). *Razvoj modela za integrisano upravljanje izborom mera prilagođavanja na klimatske promene na lokalnom nivou [Development of a Model for Integrated Management of Selecting Climate Change Adaptation Measures Locally]*, (doctoral dissertation), Univerzitet u Nišu, Fakultet zaštite na radu u Nišu, Niš

Welsch, J. (2011). *Perception and Attitudes of Landowners towards Re-establishing Native Vegetation on Private Land*, (Master thesis), Lincoln University, Natural Resources Management and Ecological Engineering. Lincoln University, Baltimore

## ACKNOWLEDGEMENTS

The research is funded by Ministry of Education, Science and Technological Development of the Republic of Serbia (Contracts No. 451-03-68/2022-14/200148).

## BIOGRAPHY of the first author

**Vesna Miltojević** is a full professor at the Faculty of Occupational Safety in Niš. Holding a PhD in sociological sciences, she teaches the following courses: Sociology, Sociology of Occupational Safety, and Social Ecology.



A particular area of her interest involves the social aspects of occupational safety and environmental protection.



SNEŽANA ŽIVKOVIĆ<sup>1</sup>  
SLOBODAN MILUTINOVIĆ<sup>2</sup>  
TAMARA RAĐENOVIĆ<sup>3</sup>

<sup>1,2,3</sup> University of Niš,  
Faculty of Occupational Safety

<sup>1</sup>snezana.zivkovic@znrfak.ni.ac.rs

<sup>2</sup>slobodan.milutinovic@znrfak.ni.ac.rs

<sup>3</sup>tamara.radjenovic@znrfak.ni.ac.rs

## THE IMPACT OF COVID-19 ON THE ENVIRONMENT

**Abstract:** *Environmental problems are becoming one of the main concerns and challenges in contemporary circumstances. Depending on the content of ecological consciousness, the way of thinking, and the adopted value system, individuals perceive the environment, experience it and treat it differently. Despite being aware of extreme environmental pollution, individuals actively participate in it. The COVID-19 pandemic has raised new challenges regarding human health and the environment. The negative, harmful effect of the pandemic is reflected in human health as the virus causes respiratory infections of varying intensity that can even be fatal. In addition to the negative consequences for people's health, the COVID-19 pandemic also has positive consequences in terms of environmental protection, especially at the begging of the pandemic. Namely, the reduced mobility of people due to travel restrictions has led to the reduced use of carbon emissions and resulted in a positive impact on climate change. However, the pandemic has also caused the generated microplastics to persist in the environment and continue to pose risks to human health and the environment. Therefore, this study aims to assess the extent of the environmental effects of the pandemic and identify knowledge gaps and future research directions.*

**Keywords:** environment, pandemic, effects, consequences.

### INTRODUCTION

The COVID-19 pandemic has been attracting the interest of researchers worldwide due to its health, economic, social, and environmental consequences. The health systems have been under extreme pressure and their economic sustainability and resilience have been jeopardized. This health shock especially pointed out the necessity for alignment of capacities and capabilities of the health systems towards preventing pandemics, while at the same time maintaining the primary health services at a satisfactory level. Rađenović et al. (2022) investigated the effectiveness and responsiveness of health systems to the COVID-19 pandemic in the European Union (EU) countries. The obtained results reveal that higher investments in health systems improve the capacities and capabilities of the health systems to prevent, detect and rapidly respond to the pandemic, i.e., their overall efficiency and responsiveness.

This health crisis has also left a deep mark on economic and social welfare on a global level. There have been many studies investigating the effects of the pandemic on economic and social developments in the world (Jones et al., 2021; Mensi et al., 2020; Zhang et al., 2020; Green and Loualiche, 2021; Ozkan, 2021).

Besides the negative consequences on human health and economies, COVID-19 has had huge environmental effects. Attributable to the pandemic, govern-

ments worldwide have restricted the movement of people and public transport and halted industrial activities (Facciola et al., 2021). These restrictions have had significant environmental consequences. According to Atoufi et al. (2021), COVID-19 has had a double impact on the environment: positive – as it reduced air, water, and noise pollution, greenhouse gas emissions, and human exposure to the environment, and negative – as it damaged ecosystems by increased generation of solid waste microplastics. Therefore, this study aims to assess these double-sided environmental consequences.

The paper is organized as follows. After the introduction, the emergence of the COVID-19 pandemic is presented followed by its positive and negative effects on the environment. Finally, the conclusion summarises the main findings that can contribute to enhanced environmental outcomes in the case of future pandemics.

### EMERGENCE OF THE PANDEMIC

COVID-19 is a coronavirus pandemic caused by the SARS-CoV-2 coronavirus disease. The first case was recorded in the city of Wuhan, China, which had a population of 11 million, on December 8, 2019. The emergence of this virus caused panic among health institutions because of its rapid spread. The first name for this virus was 2019-nCoV acute respiratory infection (January 2020) and it was later changed to COVID-19 in February 2020 by the WHO (Pal et al., 2020), while the International Committee on Taxon-



omy of Viruses (ICTV) gave the name severe acute respiratory syndrome coronavirus 2 (SARS-CoV-2) (Lai et al., 2020). Due to a large number of deaths on March 11, 2020, the coronavirus pandemic was declared. Globally, from the beginning of the pandemic to August 25, 2022, there have been recorded 596,119,505 confirmed cases of COVID-19 including 6,457,101 deaths (WHO, 2022).

In Europe, the coronavirus infection officially first appeared in Northern Italy (February 21, 2020) from where it spread to other European countries (Cerqua and Di Stefano, 2022). Italy, Spain, the United Kingdom, Germany and Russia were the hardest hit by the pandemic, with the highest number of patients and the highest number of deaths. Due to such a situation, various measures had been taken all over the world: quarantines, lockdowns, border closures, etc. At the end of March 2020, almost a quarter of the world's population was in isolation.

The pandemic caused the biggest economic shock, which led to various changes and adjustments to the conditions in which people found themselves. The emergence of the pandemic also caused the adoption of new, different decisions about the environment. Such changed decisions and actions should continue even after COVID-19. Principally, the pandemic has emphasised humanity and environmental protection. It represents an incentive and a movement to build something better in a way that will directly affect the climate crisis (Kaslijer, 2021).

As we mentioned at the beginning of the study, the existence of the pandemic has caused a double effect. The negative, harmful effect of the existence of the pandemic has been reflected in people's health. People with a higher risk of being infected with this disease have been older people and those with chronic diseases. The virus has caused respiratory infections of varying intensities, leading to death. Additionally, air pollution is linked to a higher risk of dying from COVID-19. People with pre-existing chronic conditions linked to air pollution have got severe cases of COVID-19 in

countries with high levels of pollution. An American study by Wu et al. (2020) points out that the death rate from COVID-19 jumps by about 15% in areas with even a small increase in the level of pollution from fine particles in the years before the pandemic. The death rate from COVID-19 mainly follows areas of high population density and areas with high exposure to harmful particles. Studies from the University of Siena, Italy and the University of Aarhus, Denmark, show a possible link between high levels of air pollution and deaths from COVID-19 in Northern Italy (Kadka, 2020).

In addition to the negative consequences for people, the question was to what extent the COVID-19 pandemic would affect the environment – positively and negatively (Figure 1). The pandemic has caused people to turn to nature again and seek 'protection' from the virus, as well as to distance themselves. Thus, the pandemic has had a double impact: on the one hand, it has a negative impact on human civilization in the context of social activities, and on the other hand, it has a positive impact on the environment and its importance for the well-being of people (Hanić and Mitić, 2020).

### POSITIVE IMPACT ON THE ENVIRONMENT

The negative consequences of COVID-19 on human health have brought with it numerous advantages related to environmental protection. One of the advantages is the reduced mobility of people in cities and travelling on vacations over long distances. These measures have had a direct impact on reduced carbon emissions, thus improving the welfare of nature.

Furthermore, according to Kaslijer (2021), COVID-19 has awakened consciousness in people about their actions and the consequences of their activities. Working and spending more time at home have affected invisible actions to become clearly visible, thus leading to changes in human behaviour.

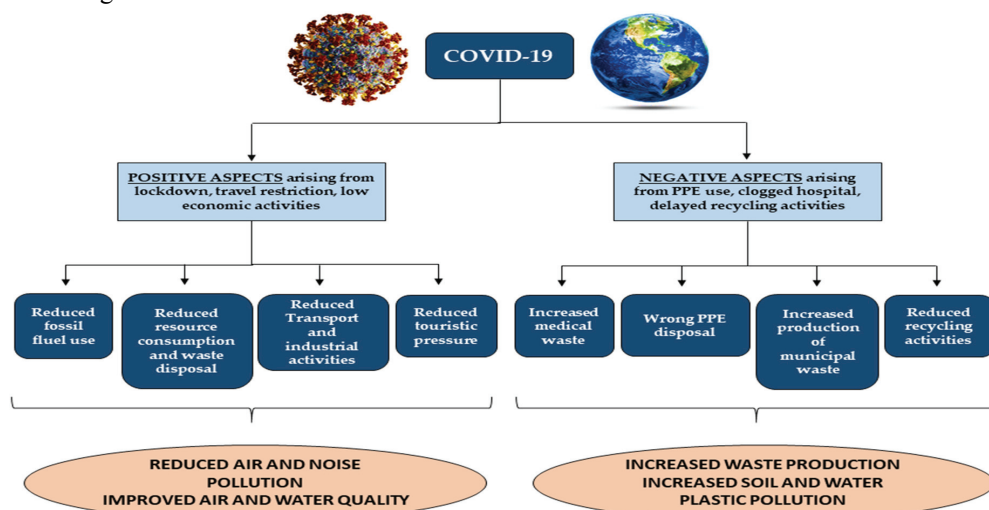


Figure 1. Impacts of COVID-19 on the environment, Source: Facciola et al. (2021, p. 3)

An example is food, i.e., the amount of food people throw away, which could lead them to change their habits. Many of these temporary sustainable changes were accidental side effects of people's response to the threat of the virus, rather than sincere concerns for the planet. Due to greater awareness and less pollution of the environment, environmental psychologists call it the "spillover effect" (Kaslijer, 2021).

Many researchers have been engaged in researching the changes caused by the presence of the COVID-19 pandemic, i.e., the effect of the temporary slowdown of human activities and their results in terms of the environment. The positive relationship between COVID-19 and the environment has been documented in the studies by Aydın et al., (2020), Bao and Zhang (2020), Chakraborty and Maity (2020), Eroğlu (2021), Gautam and Hens (2020), Lokhandwala and Gautam (2020), Mahato et al., (2020), Mousazadeh et al. (2021), Ray et al., (2020), Rodríguez-Urrego and Rodríguez-Urrego, (2020), Saadat et al., (2020), SanJuan-Reyes et al., (2021), Shakil et al. (2020), Sharma et al., (2020), etc. These studies mostly focused on researching the positive impacts in terms of reduced air and noise pollution, improved air and water quality stemming from the lockdowns, travel restrictions, and reduced economic activities (Figure 1).

One of the consequences of the movement restrictions during the isolation has led to increased time people spend in nature. In addition to being in nature, an increasing number of people are interested in birds, plants, and trees, which is concluded based on searches on the topic of "bird sounds", "recognize trees" and "growing plants" (Kaslijer, 2021). Greater participation in nature could change the attitude towards the environment. Certainly, these changed routines, caused by the pandemic, will offer an opportunity for the transition to sustainable lifestyles, which encourage the use of environmentally friendly products and services.

Additionally, the temporary slowdown of human activities has affected other species. Rutz et al. (2020) have pointed out that many animal species enjoy peace and quiet, which resulted in the free movement of wild animals in urban areas, for example, "pumas in downtown Santiago, Chile, of dolphins in untypically calm waters in the harbour of Trieste, Italy" (p. 1156). However, in some places, the lack of human activity caused more damage, and poaching occurred due to poverty, and lack of ecotourism (Gil, 2020). Although stopping people's negative influences is very difficult, it can be learnt a lot from such events.

## NEGATIVE IMPACT ON THE ENVIRONMENT

Despite the numerous positive impacts of COVID-19 on the environment, some of the consequences cannot be seen as positive. Since the beginning of the pandemic, there has been significant growth in the use of plastic and other disposable products (Shams et al., 2021). Medical waste, which primarily includes masks

and other types of protective equipment used by medical personnel, also recorded a significant increase. Hospitals have been under pressure due to insufficient capacities for adequate disposal of waste materials.

The plastic pollution problems have been intensified due to hygiene concerns and greater dependence on takeaway food during COVID-19 (Shams et al., 2021). Bondaroff and Cooke (2020) anticipated that oceans would be overwhelmed with face masks produced during the pandemic, resulting in 5159-6878 tons of plastic pollution only from masks. As face masks can be easily swallowed by fishes, thus threatening aquatic life, the whole food chain can be jeopardized causing chronic health problems for people (Aragaw, 2020; Facciola et al., 2021). Besides, the unrememberable increase in plastic waste generation and lockdowns have declined plastic recycling worldwide (Parashar and Hait, 2021). This altogether would lead to the mishandling of plastic waste resulting in improper incineration, illegal dumping, and overloading of the landfills' capacities (Benson et al., 2021).

The negative impact of the excessive use of face masks and other Personal Protective Equipment (PPE) during the COVID-19 pandemic on the environment has been documented in studies by Adyel (2020), Ammendolia et al. (2021), Aragaw (2020), Cordova et al. (2021), Cornelio et al. (2022), De-la-Torre et al. (2021), Dharmaraj et al. (2021), Du et al. (2022), Fadare and Okoffo (2020), Haddad et al. (2021), Hu et al. (2022), Prata et al. (2020), Ray et al. (2022), Selvaranjan et al. (2021), Silva et al. (2021a), Silva et al. (2021b), etc. The results from these studies point to the necessity to take immediate action for reducing waste generation, increasing recycling, and providing efficient waste management.

## CLIMATE CHANGE AND PANDEMIC

COVID-19 has put the health systems under scrutiny to see if they are able to cope with future health consequences caused by climate change (HEAL, 2020). The recovery from the pandemic offers a crucial moment for action aimed at mitigating the consequences of climate change. A joint response to converging crises offers a chance to improve public health, create a sustainable economy and protect the environment (HEAL, 2020). Governments are expected to make environmental protection a priority in their plans for recovery from the coronavirus pandemic.

No country, rich or poor, is immune to the health consequences of worsening climate change. If measures are not taken, climate impacts will leave a mark on people's health, endanger their lives and change their way of life. In this way, it will lead to a burden on the health systems. Health and climate change clinicians and academics argue that action must be taken as soon as possible to combat climate change by limiting global temperatures to well below 2°C compared to preindustrial levels, thus preventing the effects of climate change and achieving health and economic benefits.

However, due to huge economic losses and uncertainty in world markets, the issue of the environment was put 'on hold', which was especially felt in the domain of sustainable investments. A large number of EU member countries have been of the opinion that the Green Deal should be the basis for the fight against the consequences of the COVID-19 pandemic (Hanić and Mitić, 2020). The European Commission (EC) has established a new program called 'NextGenerationEU' of EUR 806.9 billion to support economic, social and environmental recovery from COVID-19 toward sustainable and resilient Europe (EC, 2021). The 'NextGenerationEU' sets new priorities which include (EC, 2021; Hanić and Mitić, 2020):

- Supporting investments and reforms in member states, mainly focusing on research, innovation, and green and digital transition;
- Restarting the economy and encouraging private investments through the instruments for strategic investments;
- Drawing lessons from the crisis regarding strengthening the efficiency and responsiveness of health systems.

In addition to the institutional fight against the consequences of the pandemic, a big challenge remains when it comes to human behaviour. We have elaborated above on the negative consequences of human actions regarding unconscious waste disposal. Although we are all aware of it, we still participate in it, thus leading to the deterioration of the environment and the quality of life.

## CONCLUSION

The environment represents the space in which different types of organisms arise and live. Thanks to previous knowledge about pollution, expansion, degradation of the Earth's surface and the resulting consequences, today we can consider the planet Earth as the environment. Hence, the planet Earth is our living environment, as it alone represents a unique system made up of the lithosphere, hydrosphere, atmosphere and biosphere.

People affect the environment in which they live through their actions. Currently, there is growing information about the threat and suffering to ecosystems from human hands. Human activity is a reflection of chemical substances on living organisms, on people, animals and plants. Endangerment of the environment, life on Earth, reduction of oxygen, certain species, and genetic changes are all the consequences of the polluting substances, reduction of the plant cover of the Earth, climate changes, changes in the composition of the spheres, changes in the number of living species and changes in their organisms, changes in radiation intensity and a number of other actions. The complex community of living organisms and the environment is destroyed and their mutual connections are broken. We are all witnesses of environmental pollution.

Environmental protection represents a complex of technical, technological and organizational procedures. The emergence of the COVID-19 pandemic can be viewed as another protection measure for environmental protection. Soon after its appearance in Europe, many countries around the world introduced various restriction measures regarding the movement of people and public transport, lockdowns, halting business operations, and closing borders. The pandemic severely hit the older population and those with pre-existing medical problems, frequently leading to death, and resulting in the total collapse of health systems across countries. It has had a harmful effect on human health. Therefore, we can conclude that the COVID-19 pandemic has negative effects and disadvantages in terms of the human population.

However, the pandemic has helped many to emphasize humanity and environmental protection. It has caused the biggest economic shock, which led to various changes and adjustments to the conditions in which people found themselves. The existence of the COVID-19 pandemic has brought benefits to the environment in terms of the reduced mobility of people, and therefore the reduction of travel in remote areas, thus bringing about the well-being of nature. Furthermore, it has raised awareness about the consequences of human actions on the environment, as greater participation in nature changes attitudes towards the environment.

However, in addition to the series of advantages regarding the environment that the pandemic has brought with it, there has been an increased need for the use of single-use plastic medical materials. In this way, a larger amount of waste has occurred, due to insufficient capacity for adequate disposal of medical waste.

Based on the review of the conducted research on the COVID-19 pandemic, its impact, consequences and environmental protection, it can be pointed out that the pandemic has a dual impact: on the one hand, a negative impact on human civilization in the context of social activities, health systems and environmental problems, and on the other hand, a positive impact on the environment and its importance for the well-being of humans.

From the paper, it is evident that most of the studies have focused either on the positive or negative consequences of COVID-19 on the environment, and there have been few attempts for a comprehensive study on both positive and negative environmental consequences. This study even goes beyond as it investigates altogether the effects of the COVID-19 pandemic on human health, social activities, and the environment.

The findings presented in this study can be helpful for setting guidelines for improving the environmental consequences of the upcoming pandemic. The double-sided issue regarding environmental outcomes can be a good starting point for future research investigating the factors causing these positive and negative consequences.

## REFERENCES

- Adyel, T. M. (2020). 'Accumulation of plastic waste during COVID-19', *Science*, 369(6509), pp. 1314-1315.
- Ammendolia, J., Saturno, J., Brooks, A. L., Jacobs, S., Jambeck, J. R. (2021). 'An emerging source of plastic pollution: environmental presence of plastic personal protective equipment (PPE) debris related to COVID-19 in a metropolitan city', *Environmental Pollution*, 269, 116160.
- Aragaw, T. A. (2020). 'Surgical face masks as a potential source for microplastic pollution in the COVID-19 scenario', *Marine Pollution Bulletin*, 159, 111517.
- Atoufi, H. D., Lampert, D. J., Sillanpää, M. (2021). 'COVID-19, a double-edged sword for the environment: a review on the impacts of COVID-19 on the environment', *Environmental Science and Pollution Research*, 28(44), pp. 61969-61978.
- Aydın, S., Nakiyingi, B. A., Esmen, C., Güneysu, S., Ejjada, M. (2021). 'Environmental impact of coronavirus (COVID-19) from Turkish perspective', *Environment, development and sustainability*, 23(5), pp. 7573-7580.
- Bao, R., Zhang, A. (2020). 'Does lockdown reduce air pollution? Evidence from 44 cities in northern China', *Science of the Total Environment*, 731, 139052.
- Benson, N. U., Bassey, D. E., Palanisami, T. (2021). 'COVID pollution: impact of COVID-19 pandemic on global plastic waste footprint', *Heliyon*, 7(2), e06343.
- Bondaroff, T. P., Cooke, S. (2020). Masks on the beach: the impact of COVID-19 on marine plastic pollution, *OceansAsia*, [online], available: <https://oceansasia.org/covid-19-facemasks/> [Accessed 22 Aug 2022].
- Cerqua, A., Di Stefano, R. (2022). 'When did coronavirus arrive in Europe?', *Statistical Methods & Applications*, 31(1), pp. 181-195.
- Chakraborty, I., Maity, P. (2020). 'COVID-19 outbreak: Migration, effects on society, global environment and prevention', *Science of the Total Environment*, 728, 138882.
- Cordova, M. R., Nurhati, I. S., Riani, E., Iswari, M. Y. (2021). 'Unprecedented plastic-made personal protective equipment (PPE) debris in river outlets into Jakarta Bay during COVID-19 pandemic', *Chemosphere*, 268, 129360.
- Cornelio, A., Zanoletti, A., Federici, S., Ciacci, L., Depero, L. E., Bontempi, E. (2022). 'Environmental Impact of Surgical Masks Consumption in Italy Due to COVID-19 Pandemic', *Materials*, 15(6), 2046.
- De-la-Torre, G. E., Rakib, M. R. J., Pizarro-Ortega, C. I., Dioses-Salinas, D. C. (2021). 'Occurrence of personal protective equipment (PPE) associated with the COVID-19 pandemic along the coast of Lima, Peru', *Science of The Total Environment*, 774, 145774.
- Dharmaraj, S., Ashokkumar, V., Hariharan, S., Manibharathi, A., Show, P. L., Chong, C. T., Ngamcharussrivichai, C. (2021). 'The COVID-19 pandemic face mask waste: a blooming threat to the marine environment', *Chemosphere*, 272, 129601.
- Du, H., Huang, S., Wang, J. (2022). 'Environmental risks of polymer materials from disposable face masks linked to the COVID-19 pandemic', *Science of The Total Environment*, 152980.
- EC (2021). *The EU's 2021-2027 long-term budget and NextGenerationEU: facts and figures*, [online], available: <https://data.europa.eu/doi/10.2761/808559> [Accessed 26 Aug 2022].
- Eroğlu, H. (2021). 'Effects of Covid-19 outbreak on environment and renewable energy sector', *Environment, Development and Sustainability*, 23(4), pp. 4782-4790.
- Facciola, A., Laganà, P., Caruso, G. (2021). 'The COVID-19 pandemic and its implications on the environment', *Environmental Research*, 201, 111648.
- Fadare, O. O., Okoffo, E. D. (2020). 'Covid-19 face masks: A potential source of microplastic fibers in the environment', *The Science of the total environment*, 737, 140279.
- Gautam, S., Hens, L., (2020). 'COVID-19: Impact by and on the environment, health and economy', *Environment, Development and Sustainability*, 22(6), pp. 4953-4954.
- Gil, V. (2020). *Korona virus: Naučnici proučavaju životinje tokom „pauze od ljudi“*, BBC News na srpskom, [online], available: <https://www.bbc.com/serbian/lat/svet-53167415> [Accessed 20 Aug 2022].
- Green, D., Loualiche, E. (2021). 'State and local government employment in the COVID-19 crisis', *Journal of Public Economics*, 193, 104321.
- Haddad, M. B., De-la-Torre, G. E., Abelouah, M. R., Hajji, S., Alla, A. A. (2021). 'Personal protective equipment (PPE) pollution associated with the COVID-19 pandemic along the coastline of Agadir, Morocco', *Science of The Total Environment*, 798, 149282.
- Hanić, A., Mitić, P. (2020). *Uticaj COVID-19 na životnu sredinu i energetski sektor*. In: Black swan in the world economy 2020. Institut ekonomskih nauka, Beograd, pp. 141-157. ISBN 978-86-89465-54-9.
- HEAL (2020). *Nijedna zemlja nije imuna na zdravstvene posledice izazvane klimatskim promenama – pandemija COVID-19 nudi uvid u kvalitet života i egzistenciju u budućnosti*, Health and environment alliance, [online], available: [https://www.env-health.org/wp-content/uploads/2020/12/Saopstenje-za-medije\\_The-Lancet-Countdown\\_-Zdravlje-i-Klimatske-promene.pdf](https://www.env-health.org/wp-content/uploads/2020/12/Saopstenje-za-medije_The-Lancet-Countdown_-Zdravlje-i-Klimatske-promene.pdf) [Accessed 20 Aug 2022].
- Hu, T., Shen, M., Tang, W. (2022). 'Wet wipes and disposable surgical masks are becoming new sources of fiber microplastic pollution during global COVID-19', *Environmental Science and Pollution Research*, 29(1), pp. 284-292.
- Jones, C., Philippon, T., Venkateswaran, V. (2021). 'Optimal mitigation policies in a pandemic: Social distancing and working from home', *The Review of Financial Studies*, 34(11), pp. 5188-5223.
- Kadka, S. N. (2020). *Korona: Zagađenje vazduha povezano sa većim rizikom umiranja od Kovid-19*. BBC News na srpskom, [online], available: <https://www.bbc.com/serbian/lat/svet-52385908> [Accessed 20 Aug 2022].
- Kaslijer, E. (2021). *Korona virus i ekologija: Kako pandemija može spasiti životnu sredinu*, BBC News na srpskom, [online], available: <https://www.bbc.com/serbian/lat/svet-53322963> [Accessed 20 Aug 2022].
- Lai, C. C., Shih, T. P., Ko, W. C., Tang, H. J., Hsueh, P. R. (2020). 'Severe acute respiratory syndrome coronavirus 2 (SARS-CoV-2) and coronavirus disease-2019 (COVID-19): The epidemic and the challenges', *International journal of antimicrobial agents*, 55(3), 105924.
- Lokhandwala, S., Gautam, P. (2020). 'Indirect impact of COVID-19 on environment: A brief study in Indian context', *Environmental research*, 188, 109807.
- Mahato, S., Pal, S., Ghosh, K. G. (2020). 'Effect of lockdown amid COVID-19 pandemic on air quality of the megacity Delhi, India', *Science of the total environment*, 730, 139086.

- Mensi, W., Sensoy, A., Vo, X. V., & Kang, S. H. (2020). 'Impact of COVID-19 outbreak on asymmetric multifractality of gold and oil prices'. *Resources Policy*, 69, 101829.
- Mousazadeh, M., Paital, B., Naghdali, Z., Mortezaia, Z., Hashemi, M., Karamati Niaragh, E., ... Emamjomeh, M. M. (2021). 'Positive environmental effects of the coronavirus 2020 episode: a review', *Environment, Development and Sustainability*, 23(9), pp. 12738-12760.
- Ozkan, O. (2021). 'Impact of COVID-19 on stock market efficiency: Evidence from developed countries', *Research in International Business and Finance*, 58, 101445.
- Pal, M., Berhanu, G., Desalegn, C., Kandi, V. (2020). 'Severe Acute Respiratory Syndrome Coronavirus2 (SARS-CoV-2): An Update', *Cureus*, 12(3): e7423. DOI 10.7759/cureus.7423
- Parashar, N., Hait, S. (2021). 'Plastics in the time of COVID-19 pandemic: Protector or polluter?', *Science of the Total Environment*, 759, 144274.
- Prata, J. C., Silva, A. L., Walker, T. R., Duarte, A. C., Rocha-Santos, T. (2020). 'COVID-19 pandemic repercussions on the use and management of plastics', *Environmental science & technology*, 54(13), pp. 7760-7765.
- Radenočić, T., Radivojević, V., Krstić, B., Stanišić, T., Živković, S. (2022). 'The efficiency of health systems in response to the COVID-19 pandemic: evidence from the EU countries', *Problemy Ekorożwoju*, 17(1), pp. 7-15, DOI: 10.35784/pe.2022.1.01.
- Ray, D., Salvatore, M., Bhattacharyya, R., Wang, L., Du, J., Mohammed, S., ... Mukherjee, B. (2020). 'Predictions, role of interventions and effects of a historic national lockdown in India's response to the COVID-19 pandemic: data science call to arms', *Harvard data science review*, (Suppl. 1).
- Ray, S. S., Lee, H. K., Huyen, D. T. T., Chen, S. S., Kwon, Y. N. (2022). 'Microplastics waste in environment: A perspective on recycling issues from PPE kits and face masks during the COVID-19 pandemic', *Environmental Technology & Innovation*, 102290.
- Rodríguez-Urrego, D., Rodríguez-Urrego, L. (2020). 'Air quality during the COVID-19: PM<sub>2.5</sub> analysis in the 50 most polluted capital cities in the world', *Environmental Pollution*, 266, 115042.
- Rutz, C., Loretto, M. C., Bates, A. E., Davidson, S. C., Duarte, C. M., Jetz, W., ... Cagnacci, F. (2020). 'COVID-19 lockdown allows researchers to quantify the effects of human activity on wildlife', *Nature Ecology & Evolution*, 4(9), pp. 1156-1159.
- Saadat, S., Rawtani, D., Hussain, C. M. (2020). 'Environmental perspective of COVID-19', *Science of the Total Environment*, 728, 138870.
- SanJuan-Reyes, S., Gómez-Oliván, L. M., Islas-Flores, H. (2021). 'COVID-19 in the environment', *Chemosphere*, 263, 127973.
- Selvaranjan, K., Navaratnam, S., Rajeev, P., Ravintherakumar, N. (2021). 'Environmental challenges induced by extensive use of face masks during COVID-19: A review and potential solutions', *Environmental Challenges*, 3, 100039.
- Shakil, M. H., Munim, Z. H., Tania, M., Sarowar, S. (2020). 'COVID-19 and the environment: A critical review and research agenda', *Science of the Total Environment*, 745, 141022.
- Shams, M., Alam, I., Mahbub, M. S. (2021). 'Plastic pollution during COVID-19: Plastic waste directives and its long-term impact on the environment', *Environmental advances*, 5, 100119.
- Sharma, S., Zhang, M., Gao, J., Zhang, H., Kota, S. H. (2020). 'Effect of restricted emissions during COVID-19 on air quality in India', *Science of the total environment*, 728, 138878.
- Silva, A. L. P., Prata, J. C., Mouneyrac, C., Barcelò, D., Duarte, A. C., Rocha-Santos, T. (2021a). 'Risks of Covid-19 face masks to wildlife: present and future research needs', *Science of the Total Environment*, 792, 148505.
- Silva, A. L. P., Prata, J. C., Walker, T. R., Duarte, A. C., Ouyang, W., Barcelò, D., Rocha-Santos, T. (2021b). 'Increased plastic pollution due to COVID-19 pandemic: Challenges and recommendations', *Chemical Engineering Journal*, 405, 126683.
- WHO (2021). *COVID-19 Weekly Epidemiological Update - 25 August 2022*, World Health Organization, Geneva, Switzerland, [online], available: <https://covid19.who.int/> [Accessed 25 Aug 2022]
- Wu, X., Nethery, R. C., Sabath, M. B., Braun, D., Dominici, F. (2020). 'Exposure to air pollution and COVID-19 mortality in the United States: A nationwide cross-sectional study', *MedRxiv*. <https://doi.org/10.1101/2020.04.05.20054502>.
- Zhang, D., Hu, M., Ji, Q. (2020). 'Financial markets under the global pandemic of COVID-19', *Finance research letters*, 36, 101528.

## ACKNOWLEDGEMENTS

This research was supported by the Ministry of Education, Science and Technological Development of the Republic of Serbia (Agreement No. 451-03-68/2022-14/200148).

## BIOGRAPHY of the first author

**Snežana Živković** was born in Leskovac, Serbia, in 1971. She received a PhD degree in Occupational Safety from the Faculty of Occupational Safety, University of Niš. She has published over 250 papers in international monographs and leading scientific journals.



Her main areas of research include occupational safety, organizational behaviour, management and human resources, emergency management, and protection of the living and working environment.

She is currently working as a Full Professor at the Faculty of Occupational Safety in Niš, University of Niš.



LJUBICA STOJKOVIĆ<sup>1</sup>  
DRAGOSLAV PAVLOVIĆ<sup>2</sup>  
IVAN MIHAJLOVIĆ<sup>3</sup>

<sup>1,3</sup> Public Utility Company Mediana  
Niš, Republic of Serbia,

<sup>2</sup> Electricity Distribution Niš,  
The Republic of Serbia,

<sup>1</sup>ljubica.stojkovic@jpkpmediana.rs

<sup>2</sup>dragoslav.pavlovic@odt.rs

<sup>3</sup>ivan.mihajlovic@jpkpmediana.rs

## ENERGY EFFICIENCY TREATMENT OF WASTE IN THE CITY OF NIŠ

**Abstract:** *This paper presents the results of a study of the energy efficiency of the treatment of hazardous medical infectious waste and sharps by steam sterilization. By destroying microorganisms, infectious waste becomes municipal waste and is disposed of at the landfill of the Public Utility Company "Medijana" Niš. The methods described in the paper are Bovie and Disc test, Biostrip, Tachograph, Survey, and certification. The results of the research show that the treatment of infectious waste by steam sterilization is safe for health and, from the point of view of environmental protection, acceptable for the city of Niš and the Republic of Serbia. However, the high thermal power of infectious waste suggests that it may be possible to investigate the possibility of producing electricity from medical waste via plasma gasification for the purpose of sustainable and integrated waste management in the city of Niš.*

**Key words:** infectious waste, steam sterilization, process heat, plasma gasification, electricity.

## INTRODUCTION

Waste generated in healthcare facilities is a mixture of municipal and hazardous medical waste produced during the course of providing healthcare services. Only about 20% of total medical waste produced is dangerous, with the remaining 80% being common municipal waste. One-third of hazardous medical waste includes pathological, chemical and pharmaceutical waste, pressure vessels, waste containing heavy metals, whereas the remaining two-thirds comprise infectious waste containing virulent, pathogenic microorganisms that can cause infectious disease [6]. The biggest producers of infectious waste are hospitals, but it is also generated in clinics and health centers, private clinics, first aid stations, dental surgeries, home care, etc. Due to their chemical composition, infectious waste and sharp objects can be disinfected/sterilized in an autoclave or sterilizer. After that, they are shredded in shredders to reduce the volume of waste. The rest of the hazardous waste is exported to EU countries for incineration treatment.

### Determining the energy efficiency of treatment of infectious waste by sterilization

State health institutions are operationally divided into a central waste treatment facility ("CTM") and a local waste treatment facility ("LMT"). Due to its chemical composition, hazardous medical waste only allows for the sterilization of sharp objects and infectious waste. After treatment, hazardous waste becomes non-hazardous waste and is disposed of at the municipal landfill.

According to the operational model, state health institutions are divided into 2 categories: central waste treatment site (Serbian: "CTM"), site that treats waste generated from other institutions ("CTM") and local waste treatment site. The site ("LMT") is a place that treats only the generated waste (Institute for Public Health of Serbia, "Dr. Milan Jovanović Batut, 2013). The primary selection is done for the collection of infectious waste and sharp objects. Infectious waste and sharp objects are transferred to plastic PVC bags of 30 l, and hermetically sealed plastic PVC packaging of 3 l. Waste must be transported by cart in 120l PVC bags, temporarily stored in concrete secondary storage within a fenced area, for a period of no more than eight days, and sterilized.

The transportation of infectious waste from the secondary storage to the tertiary storage and the place of treatment is carried out by special ADR vehicles - pickup trucks.

The experiment was conducted in an automatic steam autoclave (Göttingen) in the Niš City Hospital, at a temperature of 121 °C, under a pressure of 1.2 bar (absolute pressure 2.1 bar), for the duration of the cycle sterilization in a period of 15 minutes in order to assess the energy efficiency of the sterilization treatment of infectious waste.

The average temperature of the hot and cold fluid at the entrance to the sterilizer, is calculated using the following expression, Eqn. (1):

$$\Delta t_u = t_{1u} - t_{2u} \text{ [}^\circ\text{C]} \quad (1)$$

where:

$t_{1u}$  – temperature of the colder fluid at the inlet to the sterilizer [°C],

$t_{2u}$  - temperature of the warmer fluid at the inlet to the sterilizer [°C].

Mean temperatures of warmer and colder fluid at the outlet of the sterilizer, calculated using the following expression, Eqn. (2):

$$\Delta t_i = t_{1i} - t_{2i} [^{\circ}C] \quad (2)$$

where:

$t_{1i}$  –temperature of the colder fluid at the outlet of the sterilizer [°C],

$t_{2i}$  - temperature of the warmer fluid at the outlet of the sterilizer [°C].

Using the following expression, the degree of energy efficiency of a steam sterilizer for the treatment of infectious waste, Eqn. (3):

$$\eta = (\Delta t_u + \Delta t_i) / 2 \quad (3)$$

where:

$\Delta t_u$  – mean temperature difference at sterilizer inlet,

$\Delta t_i$  - mean temperature difference at sterilizer outlet.

Programme Combination P30489

The programming combination P30489, which is divided into cycles, was used with MATLAB programming languages to steam sterilize infectious waste.

The degree of efficiency of sterilization, i.e., "destruction" that produces the process of destruction of pathogenic microorganisms (decontamination) depends on the type and physical state of the waste, packaging, mass, as well as process parameters. The program for the treatment of dangerous substances is marked (\*\*). The generated condensate, which was in contact with the infectious waste, is retained in the autoclave during the entire decontamination process. Exhaust air, which has been in contact with infectious waste, is released from the autoclave through a sterile filter during pre-treatment. The effect of destroying the microorganism is adjusted by the process parameters. Decontamination of small amounts of liquid infectious waste in containers that are not hermetically sealed is allowed. The following figures show the cycle of sterilization of infectious waste.

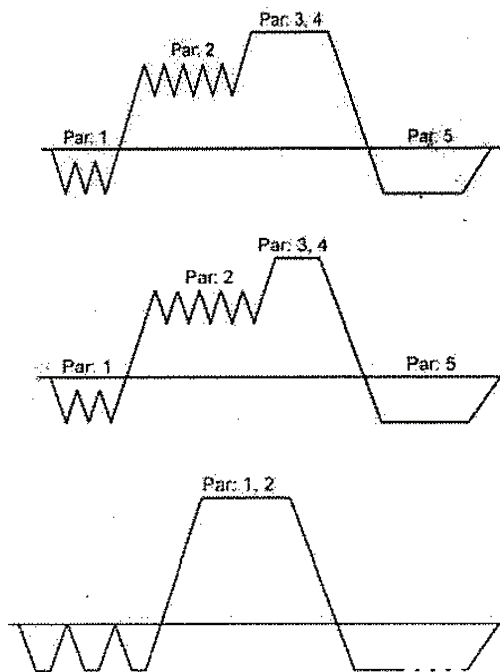


Figure 1. Infectious Waste Sterilization Cycle

The capacity of the autoclave is 24 kg of waste during a single sterilization cycle. Six 4-liter metal boxes with holes on the lids for condensate evaporation are used to distribute infectious waste bags and transport them to the autoclave, as shown in Figure 2.



Figure 2. Sterilization of infectious waste in the central waste treatment facility (“CTM”) in the City Hospital in Niš

Before sterilization of infectious waste, the Bowie-Dick method is used to inspect the empty autoclave.

The Bowie-Dick test is a method for daily monitoring of the amount of air in steam sterilizers. The test package is placed on the bottom of the autoclave before the first filling for that day, at a temperature of 134°C for 5 minutes. The presence of air reduces the sterilization temperature by two degrees, and the indicator turns yellow. Without the amount of air present, the indicator turns black and the sterilization process continues. The results of Bowie's and Dick's tests are shown in Figure 3.

Figure 3. Bowie and Dick Test

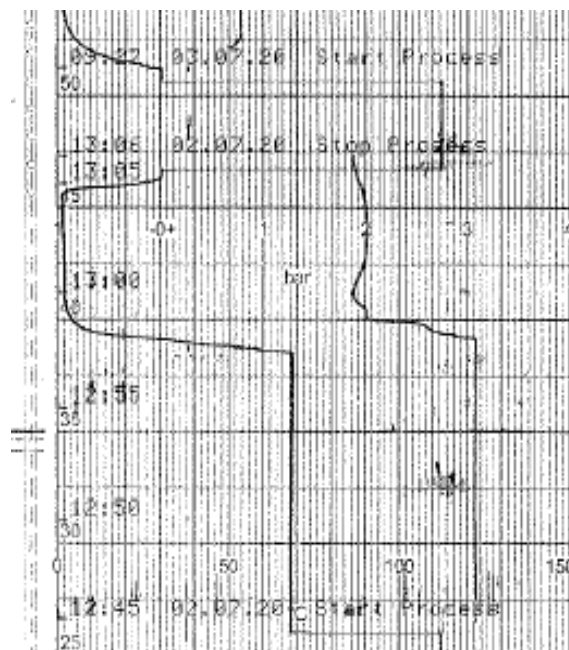
To check the sterilization of the material, ampoules with spores are placed, and distributed on the medium for the growth of infectious waste cultivated at 42 °C, and used to monitor the 24-hour sterilization cycle of infectious waste. The presence of microorganisms indicates a wrong sterilization procedure by changing the color of the indicator to yellow. The absence of microorganisms indicates the successful sterilization of the material, by changing the color of the indicator to red. The results of the Biostrip method are shown in Figure 4.



Figure 4. Biostrip method a) successful sterilization on the left; b) unsuccessful sterilization on the right

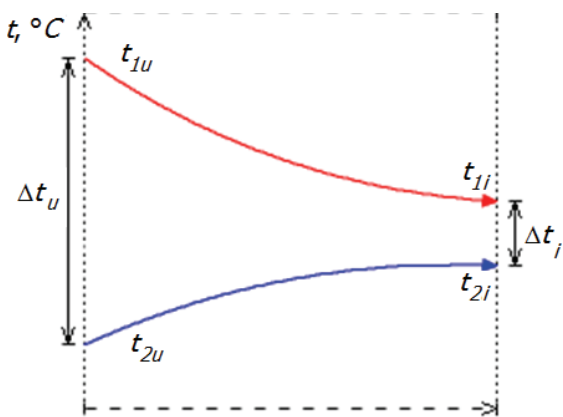
### The results of energy efficiency of an infectious waste sterilization cycle

After the infectious waste sterilization treatment, the process parameters (pressure in the chamber, temperature, duration, etc.) are shown. The result describes the temperature expansion - the decrease in the liquid temperature at the exit from the chamber, compared to the fluid temperatures at both the inlet and outlet of the steam generator  $t_1 > t_2$  (Stefanović, 1961). The energy efficiency of the infectious waste sterilization cycle is shown in Graph 1. While the thermal expansion of the sterilization cycle is shown in graph 2 (Stefanović, 1961).



Graph 1. Energy efficiency of an infectious waste sterilization cycle





Graph 2. Heat dilatation of the sterilization cycle

After the steam exits the steam autoclave, the thermal energy obtained by steam condensation in the steam generator (steam/water system) can be used in district heating systems (Pavlović, 2018).

Table 2. provides the composition of the gas produced during sterilization of medical waste by steam sterilization.

Table 2. Composition of the gas produced during the sterilization of medical waste by steam sterilization

Feed	Power (kWh)	NO <sub>x</sub>	SO <sub>2</sub>	PM
Infectious waste	50	192.06	94.6	17.1

The thermal power of the gas released during the steam generator of waste is given in Table 3. (Wilujeng, 2019, Knezević, 2004).

Table 3. Thermal power of gases obtained by steam generator for different types of medical waste

Waste Type	Heat Power	
	KJ/m <sup>3</sup>	Kwh/waste
Communal Waste	10700	4620
Medical Waste	10900	6600
Polychlorinated Biphenyls	10650	7930

**CONCLUSION**

The paper has described the treatment of infectious waste and sharpened objects and methods of disinfection/sterilization in autoclaves, single-level sterilizers, and other recognized methods that are reducing the waste volume and its hazardous properties.

After treatment, hazardous waste becomes non-hazardous waste and is disposed of at the municipal landfill.

Infectious waste can be sterilized in a manner that is both safe for human health and acceptable from the perspective of environmental preservation for the Republic of Serbia and the city of Niš. The results of the experiment of the sterilization cycle of infectious waste in the Göttingen central treatment autoclave (CTS) in the city hospital show that the treatment of infectious waste by sterilization is reliable and amounts to 64%. However, there are many disadvantages of the treatment of infectious waste by sterilization, such as: overloading of the capacity of the autoclave for infectious waste sterilization, losses of process steam, treatment of 14% of hazardous medical waste, high costs of exporting other hazardous medical waste, disposal of plastic packaging from infectious waste, need for subsequent treatment, grinding, crushing in crushers, increasing disposal capacity, etc. The above-mentioned indicates the need for a new sustainable choice of medical waste treatment method, such as plasma gasification, to obtain combined energy (Stojković, 2019, Stojković, 2022);

To support this idea, it can be stated that the treatment of the total amount of medical waste of 252.72t, the consumption of electricity from health institutions is 75.9 kVh/year, and the total amount of electricity is 463 kVh/year and the amount of heat energy is 375.59MWh. Also, the price of infectious waste treatment by plasma gasification is €0.048/kg.

**REFERENCES:**

Agić M. (2015), Agency for Statistics of Bosnia and Herzegovina, Sarejevo

Anyaegbunam F. N. C. (2014) Thermal Plasma Solution for Environmental Waste Management and Power Generation, Journal of Applied Physics (IOSR-JAP) e-ISSN: 2278-4861. Volume 6, Issue 5 Ver. III, PP 08-16

Bera, M., (2008), Analysis of the state of hazardous waste from medical institutions in Serbia and in the world, in 3rd. Conference on Quality of Life, Kragujevac

Establishment of a Modern Medical Waste Management System, Provincial Secretariat for Environmental Protection and Sustainable Development, Novi Sad, 2008

Ilić, M., (2002). Strategic Framework for Waste Management Policy, Regional Environmental Center for Central and Eastern Europe, Belgrade

Dr Intan A. (2019), Medical Waste Disposal – 2019 Definitive Guide 2019, Bio Medical System Waste Solution

Knezević L. (2004), Destruction of Municipal and Hazardous Waste Using Plasma Technology, Technological Metallurgical Faculty, Toronto, Canada

Law on Waste Management, (Official Gazette of Republic of Serbia, No 36/2009, 88/2010, 14/2016 and 95/2018 - other laws)

Lukez, S., (2005), Disposal of Medical Waste in the General Hospital Pula, <https://www.epa.gov/rcra/medical-waste> Croatian Journal of Public Health, Vol. 1: No. 3

Planning Report National Plan for Management of Waste Originating from Healthcare Institutions and Pharmaceutical Waste Contract No.08SER01/31/12/001, Implementation of Project Activities: COWI a/s (Denmark) Euro Health Group (Denmark), September 2013

Proing, Nostrification of certification - technical documentation of automatic steam sterilizer, type HS 6610 EC-1, SER.BR.2508394-272-04, PI - 01 – “Medika” - 03027-30-57/08

Pavlović T., (2018) Elektroenergetika u Srbiji i Republici Srpskoj [Electrical Energy in Serbia and Republika Srpska Academy of Sciences and Arts of the Republic of Srpska, Banja Luka

Radosavljević, J. (2008), Medical waste, *National scientific meeting Energy efficiency 08*, V. Banja, pp. 62-70

Regulation on Medical Waste Management (Official Gazette of Republic of Serbia, No 48/2019)

Report on Monitoring of the Process of Infectious Medical Waste Management in the Network of State Healthcare Institutions in the Republic of Serbia for 2013 - Regulated Waste Flows, Institute for Public Health of Serbia, "Dr. Milan Jovanović Batut"

Stefanović, V. (2019), Heating, heating and gas supply, Faculty of Mechanical Engineering 2019, ISBN - 978-86-6055-128-5

Stojković, Lj. (2019) Abstracts of Papers of the American Chemical Society

Stojković, Lj. (2022), SimTerm 2022, Book of Abstracts 20<sup>th</sup> *International Conference on Thermal Science and Engineering of Serbia Niš*, Serbia, October 18– 21, 2022

Stević, E., (2006), *Medical Waste Disposal Guide*, Ministry of Health of Canton Sarajevo, Institute for Scientific Research and Development of the Clinical Center of the University of Sarajevo, Sarajevo

Waste Management Strategy for the Period 2010-2019 (Official Gazette of Republic of Serbia, No 29/10)

Waste Management Program in the Republic of Serbia for the Period 2022 - 2031, Ministry of Environmental Protection, the program was finalized with the support of the project "Local Development Resistant to Climate Change", implemented by the Ministry and UNDP. Belgrade, 2022

Wilujeng, S.A. (2019), *Medical Waste Management in Private Clinics in Surabaya and Factors Affecting It*, International Journal of GEOMATE, Vol.16, Issue 55, pp. 34 – 39, ISSN: 2186-2982 (P), 2186-2990 (O), Japan, DOI: <https://doi.org/10.21660/2019.55.4606>, Special Issue on Science, Engineering & Environment.

Živković, Nenad V. (2001), Air protection: theoretical basis of forecasting air pollution with examples of solved tasks, Faculty of Occupational Safety, ISBN – 86-80261 - 31 - 9COBISS.SR - ID – 177695495

#### ACKNOWLEDGMENTS:

This paper was supported by the Clinical Center of Niš.

#### BIOGRAPHY OF THE FIRST AUTHOR

**Ljubica Stojković, MSc**, was born in 1976 in Niš. She graduated in 2001 from the Faculty of Occupational Safety, University of Niš. Ljubica Stojković obtained her Master's Degree in Environmental



Protection. In 2006, she became a leading waste planning and management engineer of the Public Utility Company “Mediana” Niš. Since then, she has published seven scientific papers in the field of energy efficiency and waste management.





# OESEM

19<sup>th</sup> INTERNATIONAL CONFERENCE  
"MAN AND WORKING ENVIRONMENT"

OCCUPATIONAL AND ENVIRONMENTAL SAFETY  
ENGINEERING & MANAGEMENT

## *Fire Safety Engineering and Disaster Managements*





DARKO ZIGAR<sup>1</sup>  
DUŠICA PEŠIĆ<sup>2</sup>  
MILAN BLAGOJEVIĆ<sup>3</sup>

<sup>1,2,3</sup> University of Niš,  
Faculty of Occupational Safety

<sup>1</sup> darko.zigar@znrfak.ni.ac.rs

<sup>2</sup> dusica.pesic@znrfak.ni.ac.rs

<sup>3</sup> milan.blagojevic@znrfak.ni.ac.rs

## LARGE EDDY SIMULATION OF IMPACT OF VEHICLE NUMBER AND TYPE ON FIRE DYNAMICS IN TUNNELS

**Abstract:** Fire safety in road and rail tunnels is very important due to the possibility of tunnel fire incidents involving passengers and cargo vehicles. Also, it is necessary to understand the growth and spread of fire in the tunnel in order to assess the conditions for evacuation of vulnerable people and firefighting. The rate of evacuation and the response time of fire rescue units directly depend on fire dynamics. In this paper, numerical simulations of several characteristic fires in the tunnel under various occupancy conditions with different types of vehicles were performed due to the aforementioned reasons. The CFD Large Eddy Simulation method of the Fire Dynamics Simulator software package with PiroSym graphical interface has been used to investigate the influence of the number and type of vehicles on the development and spread of fire in the tunnel. Temperature and smoke visibility inside the tunnel, as well as heat flux intensity on tunnel solid surfaces, were analyzed. The simulation results indicate that a larger number of motor vehicles in the tunnel affects the flow rates of combustion products, smoke dispersion, and temperature rise in the tunnel. The findings of this study may contribute to a better understanding of the conditions required for a safe evacuation and firefighting in the event of a tunnel fire.

**Key words:** numerical simulation, fire, tunnel, vehicles, evacuation, fire fighting.

### INTRODUCTION

As a result of the mutual interaction of physical and chemical processes, fires are generally very difficult to study. As a result of this interaction, small-scale experiments are frequently insufficient to accurately reproduce all the properties of tunnel fires. Figure 1 shows that much of the research on tunnel fires has been devoted to understanding how smoke moves and devising various installations to control it in order to establish the ideal conditions for escape, extinguishment, and rescue. Much of the research on tunnel fires, Figure 1, has focused on studying the movement of smoke and finding various installations to control it in order to create sufficient conditions for evacuation, extinguishing and rescue.



Figure 1. Tunnel fire

For research on fires in tunnels, with the development of computers, numerical fluid dynamics - Computational Fluid Dynamics – CFD, (Ingason et al 2015; Yuen et al., 2021) ie. field model is used more often.

By creating complex scenarios, it is possible to compare and analyze the effectiveness of different fire protection models. Concerning the progression of the fire, we are referring to tunnel-specific phenomena such as backflow of smoke, critical airflow velocity, and smoke stratification

In contrast to buildings, which have a relatively constant fire load and where the risk of fire can be assessed, the scenario in tunnels is quite different. The fire load in the tunnel is variable and almost unpredictable. The reason for this is that the construction of the tunnel itself is not flammable and the severity of the fire is purely determined by the sort and quantity of goods transported through it.

Therefore, there is always the possibility of catastrophic fire in the tunnels, which is almost impossible to predict. Also, tunnels do not have the possibility of zoning, which further complicates evacuation and rescue, as well as fire localization.

Even a small-scale fire can have serious consequences. The main threat is posed by pyrolysis and combustion products, specifically the resulting smoke, which can cause death in such a small space, even in small amounts.

Because the problem in fire protection is primarily based on controlling the spread of smoke, it is important to assess how the number and type of motor vehicles affect the dynamics of the fire.

By analyzing the results of the numerical simulation, adequate answers can be given about the behavior, i.e. fire dynamics in the tunnel, and considering the effectiveness of the fire protection system in them, as well as the possibility of evacuation from the tunnel, can be provided. Also, it is a good opportunity to propose new or improve the existing fire protection measures in the tunnels based on the knowledge obtained.

## MATERIALS AND METHODS

### Numerical model

The rapid development of computers, and thus numerical fluid dynamics - (Computational Fluid Dynamics - CFD), led to the development of field models (field models) such as Fire Dynamics Simulator (McGrattan et al., 2018) that are used to solve numerous requirements and problems in the field of fire protection.

The use of numerical models of fluid dynamics made it possible to describe fires in complex spaces (geometries) with very complex networks, which enables the inclusion of wide variations of physical phenomena. For this reason, they have also found great use in the investigation of fires in tunnels.

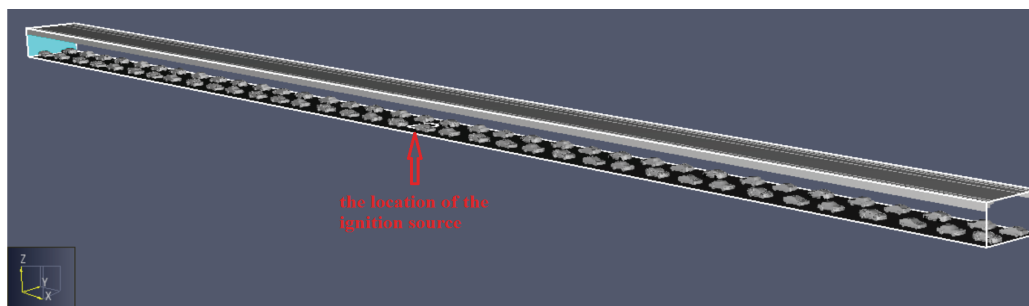


Figure 2. The layout of the 3D tunnel model used for simulation

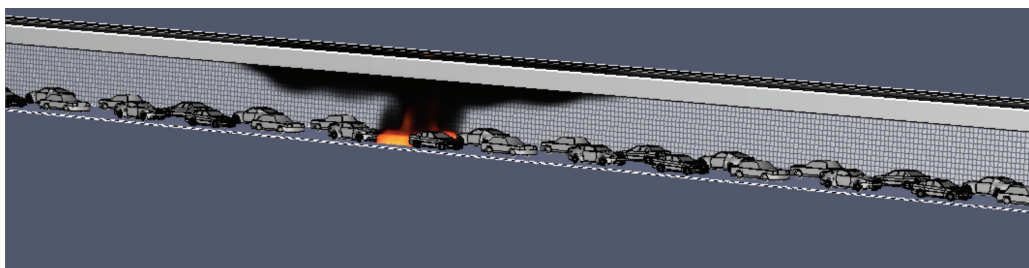


Figure 3. The layout of the numerical grid for calculation and ignition source

For fire simulation, a 3D concrete tunnel model with dimensions 300 x 11.7 x 7.1m was created in the Thunderheadeng Engenering Pyrosim software (2021), which is shown in Figure 2. A uniform numerical grid with grid cell dimensions of 0.4 x 0.4 x 0.4m, i.e. 391500 grid cells was used for calculation (Figure 3).

A fire of spilled octane fuel in the center of the tunnel was simulated with a heat release amount of 5000kW/m<sup>2</sup>, and spilled fuel dimensions of 4 x 5m, i.e. an area of 20m<sup>2</sup>, giving a total released amount of heat of 100MW. This amount of heat released corresponds to the amount of heat released in a heavy truck fire according to the NFPA 502 standard (NFPA 502).

The simulation was performed at an outside air temperature of 20°C and normal ambient pressure, with no wind. The number of vehicles and the type of vehicle was changed in the simulations.

In the first three simulations, the number of passenger

vehicles changed from 72 (100% tunnel occupancy), to 36 (50% tunnel occupancy), and then to 18 (33% tunnel occupancy). This was done with the aim to assess the impact of the number of vehicles on the movement of fire parameters such as fire development and spread, tunnel temperature, smoke visibility, and heat flux on solid surfaces.

In the last simulation, the same fire parameters were calculated when there were both passenger and cargo vehicles in the tunnel. The fire could not spread from the initialization point in the simulations because the observed vehicles were all made of sheet steel and did not contain combustible materials

Their role in the simulations is to assess the influence of the number and type of vehicles (passenger, cargo, etc.) on the movement of certain parameters, primarily on the movement, speed and visibility of smoke with the aim to assess the possibility of eventual evacuation from a tunnel affected by the fire.



Results of a fire simulation in a tunnel with 100% occupancy by passenger vehicles

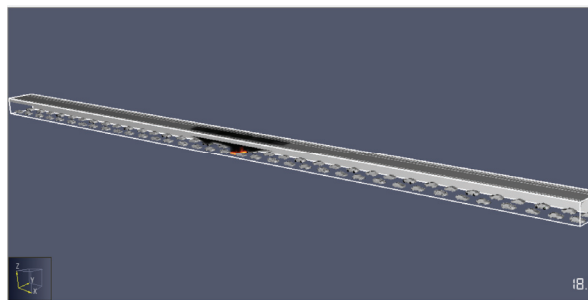


Figure 4. The layout of the 3D model of the tunnel with 100% occupancy by passenger vehicles

Fire and smoke development in a tunnel

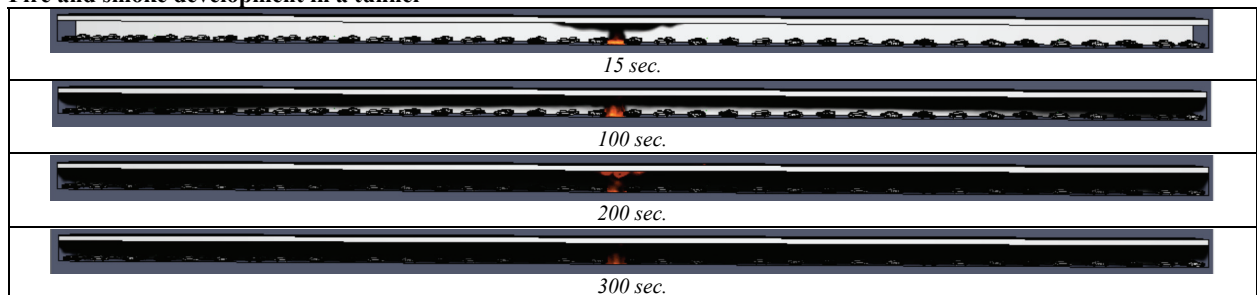


Figure 5. Fire and smoke development in a tunnel with 100% occupancy by passenger vehicles

Temperature

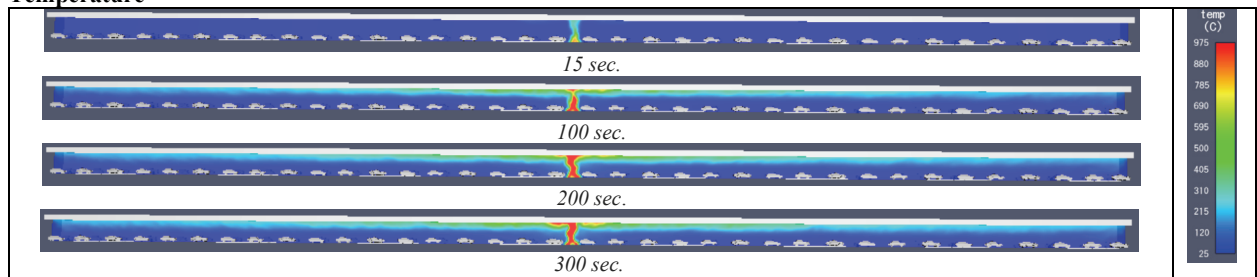


Figure 6. Fire temperature in the tunnel

Smoke visibility

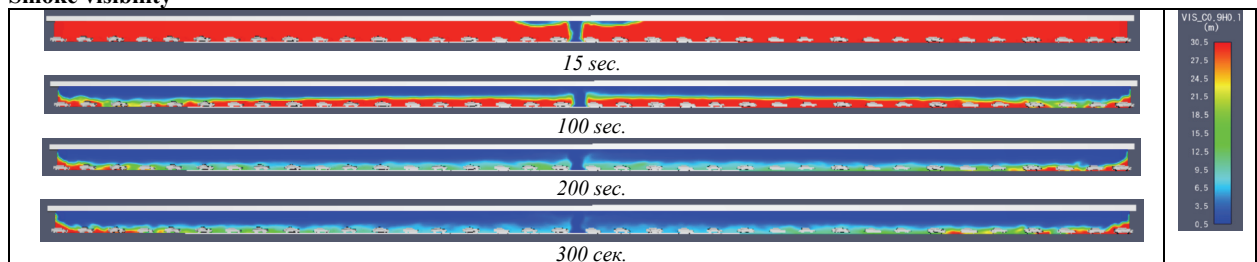


Figure 7. Smoke visibility in the tunnel

Incident heat flux

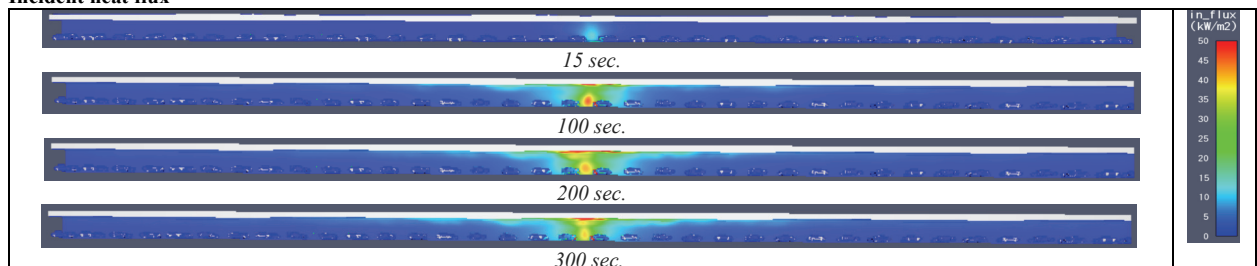
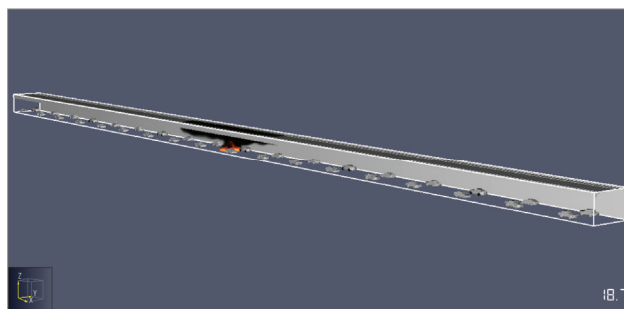


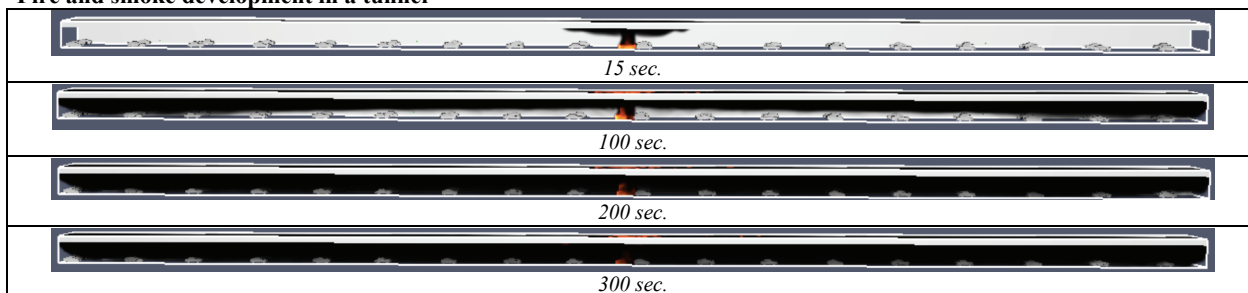
Figure 8. The incident heat flux in the tunnel

**Results of a fire simulation in a tunnel with 50% occupancy by passenger vehicles**



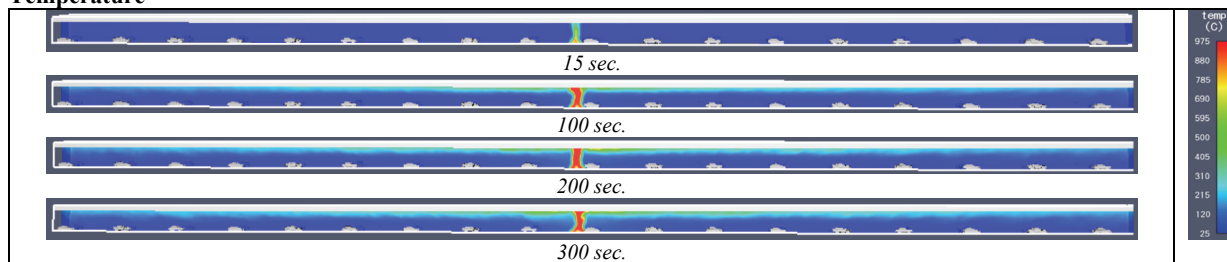
**Figure 9.** The layout of the 3D model of the tunnel with 50% occupancy by passenger vehicles

**Fire and smoke development in a tunnel**



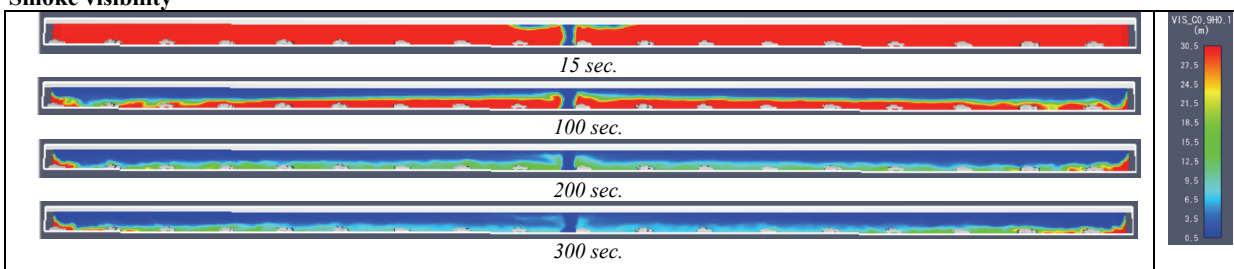
**Figure 10.** Fire and smoke development in a tunnel with 100% occupancy by passenger vehicles

**Temperature**



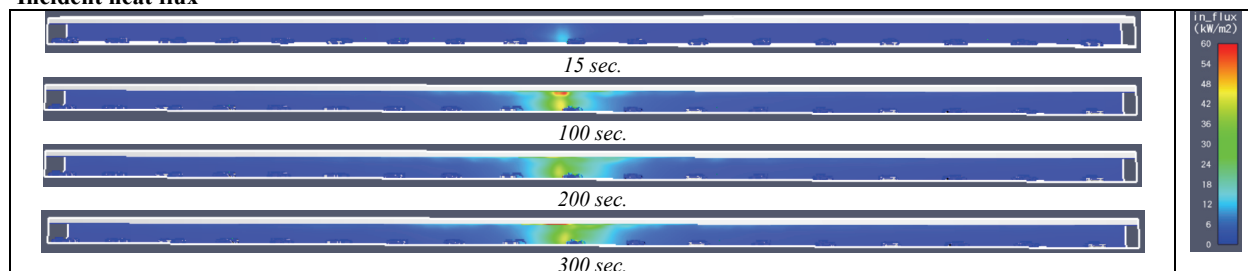
**Figure 11.** Fire temperature in the tunnel

**Smoke visibility**



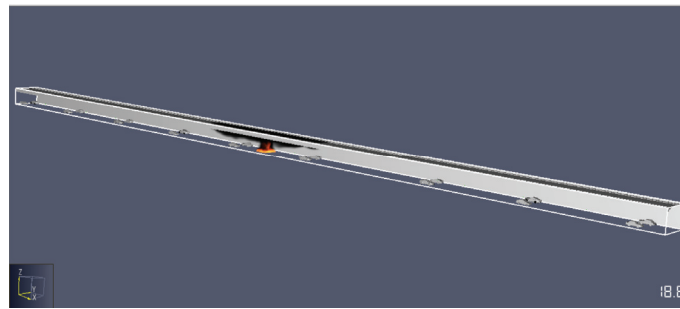
**Figure 12.** Smoke visibility in the tunnel

**Incident heat flux**



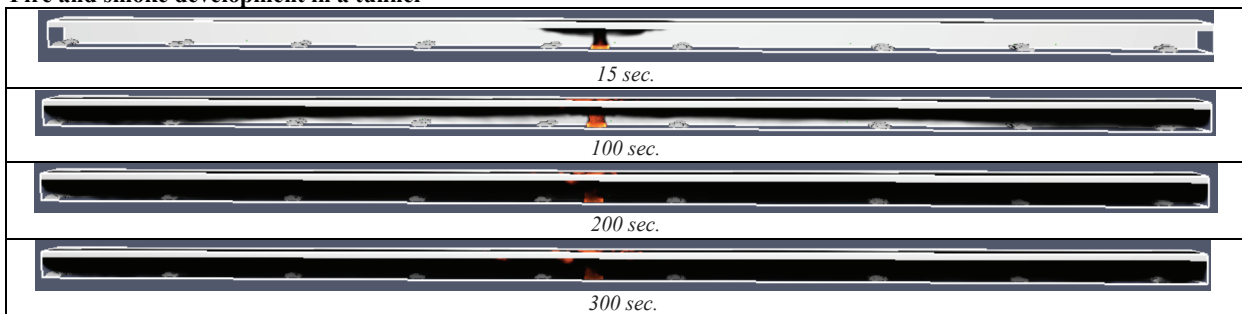
**Figure 13.** The incident heat flux in the tunnel

**Results of a fire simulation in a tunnel with 33% occupancy by passenger vehicles**



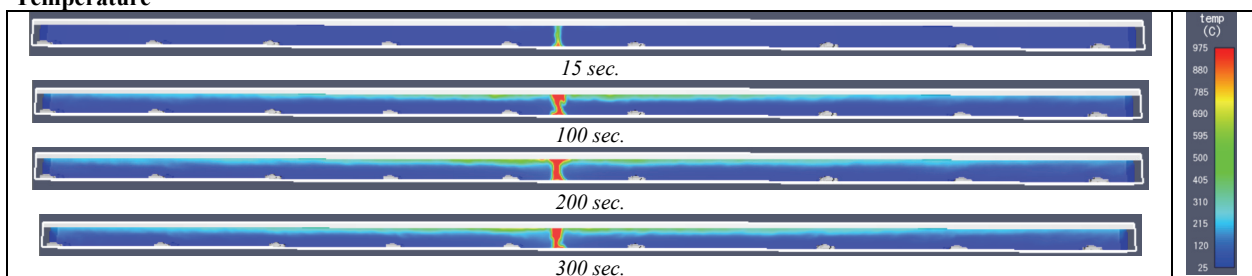
**Figure 14.** The layout of the 3D model of the tunnel with -33% occupancy by passenger vehicles

**Fire and smoke development in a tunnel**



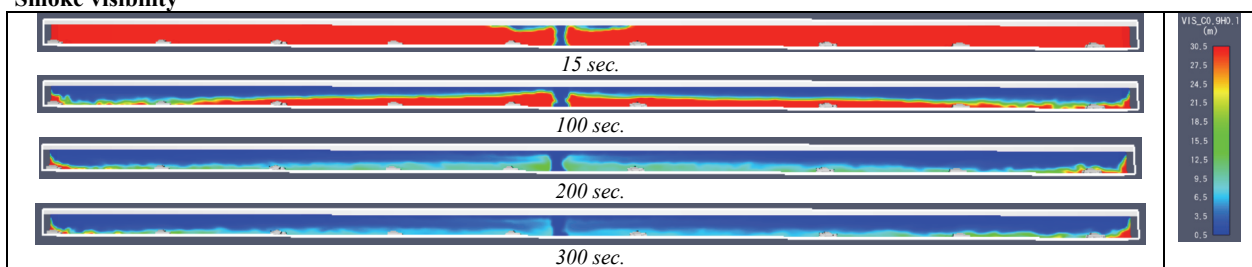
**Figure 15.** Fire and smoke development in a tunnel with 100% occupancy by passenger vehicles

**Temperature**



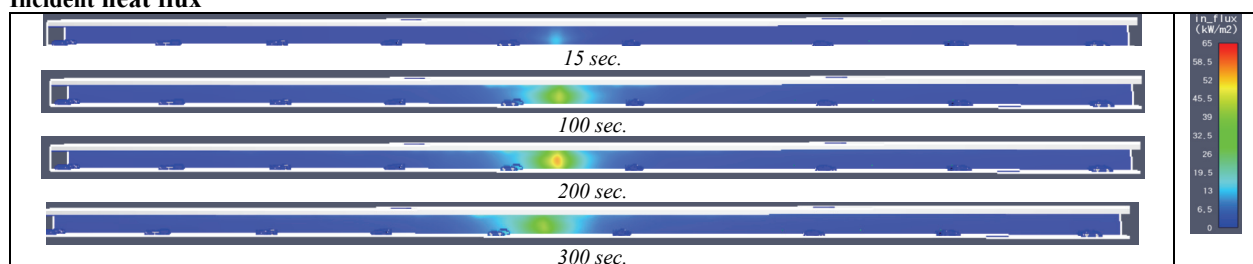
**Figure 16.** Fire temperature in the tunnel

**Smoke visibility**



**Figure 17.** Smoke visibility in the tunnel

**Incident heat flux**



**Figure 18.** The incident heat flux in the tunnel

The results of a fire simulation in a tunnel filled with passenger and cargo vehicles

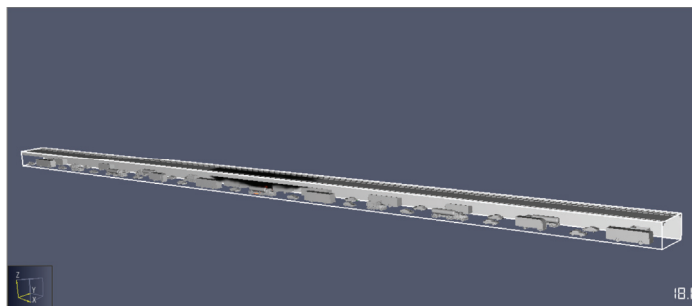


Figure 19. The layout of the 3D model of the tunnel with passenger and cargo vehicle

Fire and smoke development in a tunnel

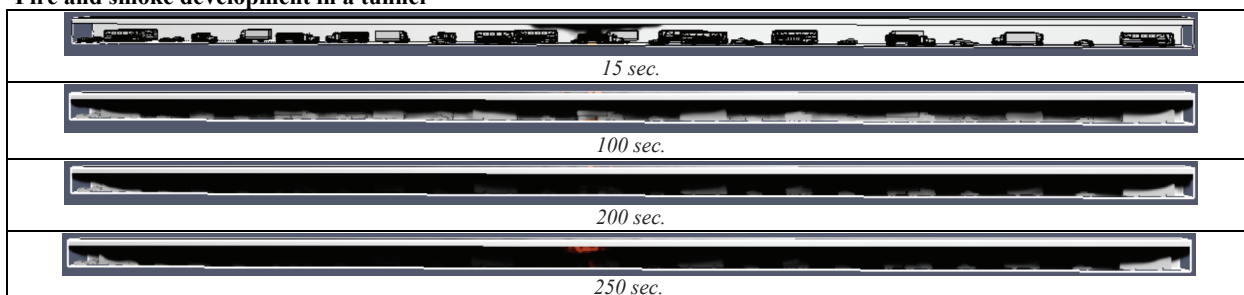


Figure 20. Fire and smoke development in a tunnel with passenger and cargo vehicle

Temperature

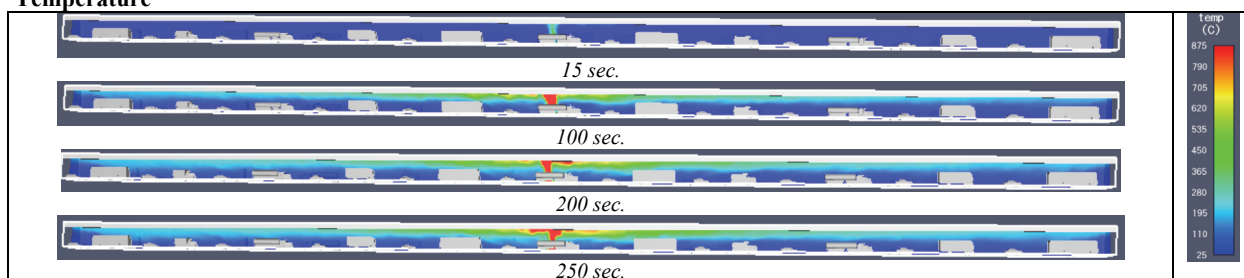


Figure 21. Fire temperature in the tunnel

Smoke visibility

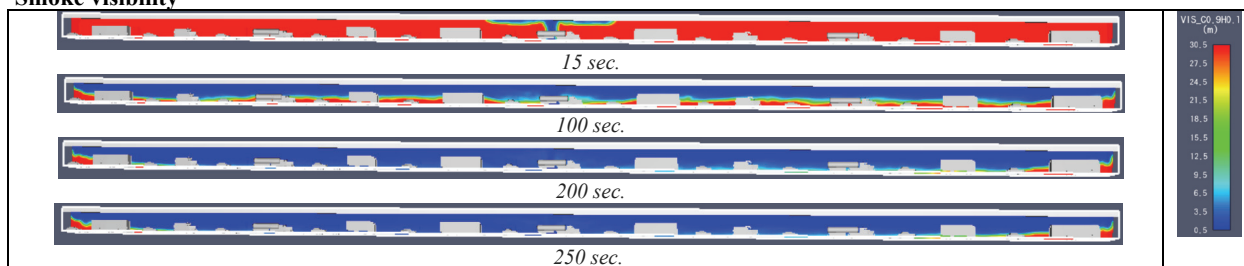


Figure 22. Smoke visibility in the tunnel

Incident heat flux

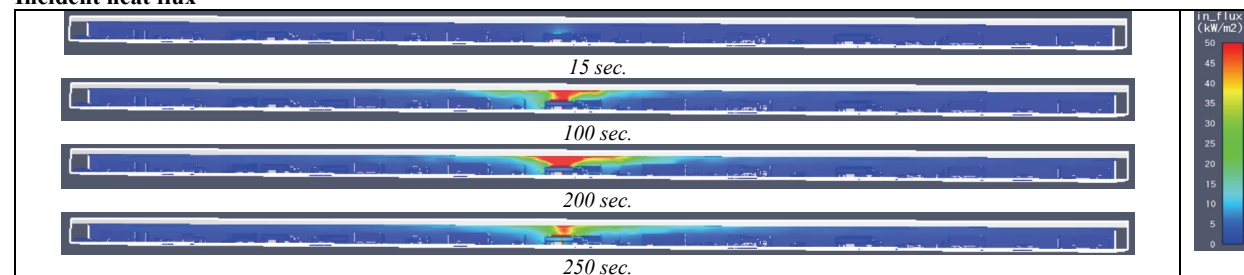


Figure 23. The incident heat flux in the tunnel

## Analysis of simulation results

**Fire development and smoke spread:** Due to the fact that the observed vehicles were all made of sheet steel and did not burn any combustible materials, the simulations did not allow for the spread of fire from the initialization point. Their role in the simulations is to evaluate the impact of the number and type of vehicles (passenger, cargo, etc.) on the movement of certain parameters, primarily the movement, speed and visibility of smoke in order to assess the possibility of eventual evacuation from the fire-affected tunnel.

The fastest smoke inhalation in the tunnel was recorded when tunnel was completely occupied by passenger vehicles and when there were also freight vehicles present. The reason for this is that the volume of space filled by combustion products is reduced. The faster the tunnel fills with smoke, the fewer vehicles there are in it. The area close to the tunnel's ceiling is fumigated the quickest, and over time the layer of smoke descends.

**Temperature in the tunnel:** The highest temperatures are recorded in the simulation when there are the most vehicles in the tunnel space. The reason for this is not only the reduction of the space that is heated but also the radiation of heat that accumulates over time on the steel sheet of the vehicle. This contributes to the further radiation of that accumulated heat, resulting in an increase in the temperature in the tunnel.

Also, a larger number of vehicles in the tunnel prevents and slows down the inflow of colder fresh air from the ends of the tunnel, necessary for the combustion process, so there is less cooling inside the tunnel.

**Smoke visibility:** The worst smoke visibility is recorded for the case with the smallest number of vehicles in the tunnel, while visibility increases as the number of vehicles in the tunnel increases. The reason for this is that, due to the reduced space in the tunnel, the speed of the combustion products near the ceiling increases, and thus a larger amount of combustion products is released.

On the other hand, the speed of the inflow of fresh air into the tunnel in the ground part increases, which contributes to better visibility at head height man. This can be crucial for evacuation from a tunnel affected by the fire. Unfortunately, in the case when we have a large number of freight vehicles in the tunnel due to their great height and volume, the entire volume of the tunnel quickly becomes smoky.

**Incident heat flux:** The lowest value of incident heat flux was recorded in the case with the largest number of passenger vehicles and the presence of freight vehicles in the tunnel, because a large part of the heat released during the fire is used to heat the metal surfaces of the vehicles. This situation will likely change if the fire burns longer than expected because those surfaces would produce more heat.

In contrast, the highest value of the incident heat flux was recorded for the case with the lowest number of vehicles.

## CONCLUSION

By analyzing the results of the numerical simulation of the fire in the tunnel in this paper, it was concluded that:

- The fastest smoke inhalation rate of the tunnel was recorded when it was completely filled with passenger vehicles and when freight vehicles were present in the tunnel. The area close to the tunnel ceiling is being fumigated the quickest, and over time the layer of smoke is descending
- The highest temperatures are recorded in the simulation when the tunnel is most densely packed with vehicles. The fastest flow of combustion products is recorded in the tunnel that is completely filled with passenger vehicles, both towards the ends of the tunnel and towards the center of the fire, whereas in other cases these velocities are lower.
- The worst smoke visibility is recorded for the case with the smallest number of vehicles in the tunnel, while visibility increases as the number of vehicles in the tunnel increases. Unfortunately, when there are a large number of freight vehicles in the tunnel, the entire volume of the tunnel quickly becomes smoky, due to their great height and volume.
- The lowest value of the incident heat flux was recorded in the case with the largest number of passenger vehicles and the presence of freight vehicles in the tunnel. This situation will most likely change if the fire burns for a longer period of time than expected because those surfaces will generate more heat. In contrast, the highest value of the incident heat flux was recorded for the case with the fewest vehicles.

Based on all this, it is possible to conclude that having a large number of motor vehicles in one tunnel has a negative impact on the rapid evacuation of people and the intervention of the fire-rescue unit.

As previously stated, this is supported by the appearance of faster smoke due to the faster flow of combustion products, as well as the accelerated increase in temperature in the tunnel.

## REFERENCES

- Ingason, H., Li, Z.,Y., and Lönnemark, A. (2015) *Tunnel Fire Dynamics*, New York, N.Y.: Springer.
- Yuen, A.C.Y., De Cachinho Cordeiro, I.M., Chen, T.B.Y., Chen, Q., Lui, H., Yeoh, G.H. (2021) Multiphase CFD modelling for enclosure fires—A review on past studies and future perspectives. *Experimental and Computational Multiphase Flow* 4 (1) available at: <https://link.springer.com/article/10.1007/s42757-021-0116-4> [accessed 14 February2011]
- (NFPA 502): *Standard for Road Tunnels, Bridges, and Other Limited Access Highways* (2020), Avon: National Fire Protection Association.



McGrattan, K., Hostikka, S., McDermott, R., Floyd, J., Weinschenk, C., Overholt K., (2018). *Fire Dynamics Simulator, Technical Reference Guide, Volume 1: Mathematical Model*, National Institute of Standards and Technology, Gaithersburg, MD.

Thunderheadeng Engenering (2021) *Pyrosim* [online], available: <https://www.thunderheadeng.com/pyrosim> [accessed 17 July 2022].

## ACKNOWLEDGEMENTS

This paper presents the results of research supported by the Ministry of Education, Science and Technological Development of the Republic of Serbia.

## BIOGRAPHY

**Darko Zigar** was born on April 16, 1973. in Pančevo, Serbia. He received a B.Sc. degree in Environmental Protection and M.Sc. degree in Occupational Safety in 2002 and 2007 respectively, from the University of Niš, Serbia. He has been with the Faculty of Occupational Safety, University of Niš, since 2008., where he is working as a researcher/assistant lecturer. In 2015, he received his doctorate and became an assistant professor at the same faculty. His areas of expertise include numerical fire simulations, as well as investigations of possible adverse effects of electromagnetic field irradiation from mobile phones and wireless systems.



NADYA KIRILOVA<sup>1</sup>

<sup>1,2</sup> Academy of the Ministry of  
Interior,  
Faculty of Fire Safety and Civil  
Protection

<sup>1</sup> nadq\_kirilova1000@abv.bg

## ANALYSIS OF THE ADMINISTRATIVE PENAL ACTIVITY OF THE RDFSCP- PLOVDIV

**Abstract:** This report presents and analyzes data on the administrative penal activity (APA) carried out for a period of 11 years at the RDFSCP-Plovdiv. Data are provided on the number of documents drawn up to establish administrative violations and the criminal decrees issued based on them, as well as the annulled criminal decrees in the judicial phase and the reasons for the annulment. The main problems and gaps in the activity of the fire safety authorities carrying out APA are shown. Conclusions and proposals for its improvement are made.

**Key words:** administrative-criminal activity, act, administrative violation, penal decree, court, inspection

### INTRODUCTION

The Regional Directorate for Fire Safety and Civil Protection Plovdiv (RDFSCP-Plovdiv) is one of the considerably overstretched regional directorates in the Republic of Bulgaria out of 28 such directorates in terms of implementation of state fire control and preventive activities – SFC and PA.

The effect of the imposition of administrative penalties and the collection of fines imposed by the fire brigade authorities in the Regional Fire Brigade of Plovdiv, as well as in the whole country, is a problem that should be discussed and workable mechanisms for its solution should be proposed. The report contains data on the number of administrative offence certificates issued, the number of penal decrees (PDs) issued on the basis of these certificates, the number of administrative criminal proceedings pending, the number of penal decrees appealed against at first instance, the number of penal decrees confirmed and annulled at first instance, the number of penal decrees annulled, the number of penal decrees confirmed at appeal, and the main reasons of the courts for the annulment of penal decrees for the period from 1 Jan 2010 to 31 Dec 2020.

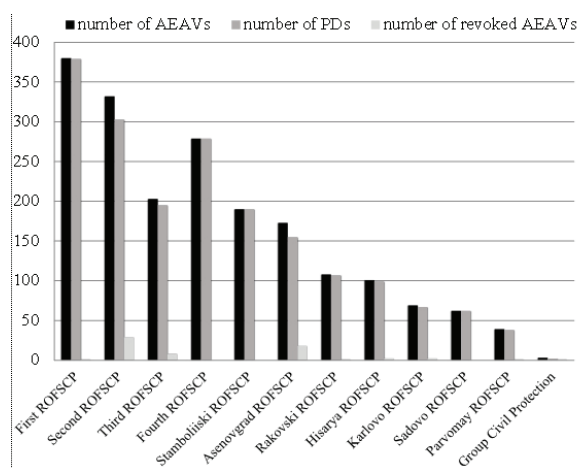
### FINDINGS

The majority of administrative penalties are imposed by the authorities for the implementation of state fire control and prevention activities. For the purpose of this study and analysis, 40 penalty decrees annulled by the courts were examined, together with their judgments, as well as 10 confirmed and one amended penalty decree. The data shown are provided by the RDFSCP-Plovdiv.

For the period from 2010 to 2020, on the territory under the jurisdiction of the RDFSCP-Plovdiv, the APA is summarized in the following data. Figure 1 illustrates the distribution of administrative penal

activities by the Regional Offices for Fire Safety and Civil Protection (ROFSCP).

**Figure 1.** Distribution of APA by the ROFSCP



According to the chart, it can be concluded that 90% of the administrative penal proceedings initiated during the period in question resulted in the issuance of a penal decree. In the remaining 53 cases, no penalty orders were issued. These are the cases in which, on the basis of objections or communications received after having been informed of the circumstances, the administrative sanctioning authority has suspended administrative penal proceedings on the basis of Article 54 of the Law on Administrative Offences and Penalties (LAOP). In the majority of the terminated proceedings (about 30) the reasons for the termination are the provisions of Article 54, paragraph 7 of the LAOP, which states that the administrative-punitive authority terminates the proceedings because at the time of drawing up the act for the establishment of an administrative violation (AEAV), significant violations were committed in the drawing up of the act, such as: incorrect description of the offence, consisting of incorrect description of the factual situation, wrongly cited normative grounds, etc. The other reason for the

termination of the administrative proceedings under the administrative procedure are the provisions of Article 43(1) of the LAOP: "The act shall be signed by the drafter and at least one of the witnesses mentioned therein and shall be presented to the offender to acquaint him with its contents and sign it with the obligation to notify the sanctioning authority when he changes his address and paragraph; (2) "Where the offender refuses to sign the report, this shall be certified by the signature of one witness, whose name and exact address shall be recorded in the report". It is important to mention that one of the major obstacles to the drawing up of a correct and complete AEAV is the lack of sufficient witnesses. In the best-case scenario, there should be two witnesses other than the compiler: an eyewitness, a witness for when the offence was detected or a witness for when the report was drawn up. Unfortunately, this is a difficult setup, given that the common practice is to appoint one inspector for a particular office in an area of operation with defined territorial boundaries, carrying out SFC and PA. The inspector alone executes the controls, which in some situations puts the inspectors at a great disadvantage, especially if a large number of administrative offences are detected and an administrative offence report has to be drawn up. In this case, the inspector tries to contact a colleague from a neighbouring district or the police authorities in order to be assisted in drawing up the report correctly. Unfortunately, the majority of people, even eyewitnesses, refuse to witness the drawing up of an AEAV for various reasons, some of which include the following: unwillingness of the witness to commit to appearing in a courtroom in a possible appeal against the penal order; relationship with or dependence on the offender; the fact that when the offender is provided with a receipt of the report, he will have access to the personal details of the witnesses, such as full name, address on identity card, and until recently the Unique Civil Number (UCN); fear of threats and self-incrimination against the witness, which is also a fairly common reason for refusal. It should be noted that in the majority of other administrations with control functions and tasked with APAs, the problematic issue is regulated much better. It should also be noted here that using an employee of an enterprise as a witness in drawing up an administrative offence report against the head or the owner of the enterprise is again not the best strategy, since, in the subsequent judicial phase, it is often the case that the witness does not remember key facts and circumstances of the factual situation described in the act, imputed as an administrative offence to the offender. For this reason, it would be advisable to consider a better distribution of the inspectorate's staff and better framing of the orders defining their territorial jurisdiction. Ideally, control checks should be performed by a minimum of two inspectors. This will facilitate their work and all the requisites of the act will be correctly and timely fulfilled.

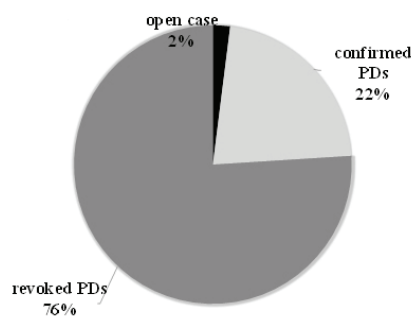
For the analyzed period, only two AEAVs were issued to legal entities, and only two financial penalties were imposed to trading companies within the meaning of Article 129 of the Ministry of Interior Act. The issued

PDs for the imposition of pecuniary sanctions were appealed before the Plovdiv District Court. Both PDs were annulled, which is sufficiently clear. One of the main reasons for not issuing an AEAV to legal entities is the amount charged by financial penalties. The higher the amount of the sanction, the greater the likelihood of its being appealed. This leads to a reluctance on the part of officials to issue AEAVs to legal persons. The number of legal advisers appointed throughout the country and the fact that very often inspectors appear alone in a courtroom, without having the necessary legal training and legal assistance provided by legal counsel, explain the massive practice of drawing up AEAVs on individuals and imposing lower fines.

In view of the above results, only three per cent of the penalty decisions for the observed period were appealed. From the point of view of the administrative-punitive activity within the RDFSCP-Plovdiv jurisdiction, this is considered a success for the employees with administrative-punitive authority and can be interpreted as a commendation of their work. Yet, this poses the question of the reason for such a high percentage of non-appeals. In practice, a large part of the administrative offence acts and the subsequent penal decrees show that the majority of the penal decrees impose a sanction on the basis of Article 265(3) of the Ministry of Interior Act. This sanction amounts to BGN 50-100 and is imposed in cases where minor offences have been committed. These penalty decrees represent one part, accounting for 60% of the total number of penalty decrees issued.

It is interesting to see what happens with these appealed penal rulings. Figure 2 illustrates the outcome of appeals against penal orders to the District Court.

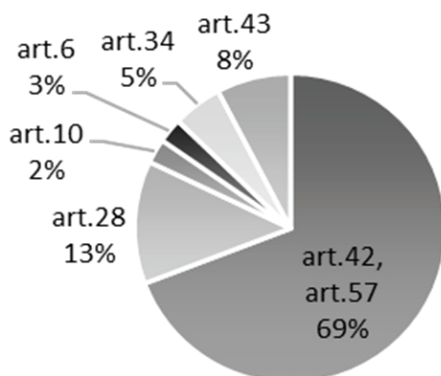
Figure 2. Results of appealed PDs to the District Court



In contrast to the low appeal rate, the picture here is quite different. Out of the total number of appealed penal decrees, only 22% were confirmed. On the basis of the number of reversed judgments, there is inconsistent case law. Different courts have interpreted the same offences differently and in a large number of cases there have been different judgments for the same content of penal rulings. After analyzing 51 judgments relating to the above-mentioned contested penal provisions, reasons for the annulment of penal provisions of a heterogeneous nature were found. In the majority of cases, the penalty decisions were annulled for infringements of Articles 42 and 57 of the Code of

Penal Procedure. Figure 3 shows the percentage of grounds for annulment:

**Figure 3.** Grounds for annulment of PDs



Several conclusions can be drawn from the above. The first is that sometimes the compilers do not respect the time limit for drawing up an AEAV, which is set out in Article 34, paragraph 1 of the LAOP, according to which no administrative proceedings shall be initiated if no AEAV is drawn up on the offender within three months of its discovery and one year from the commission of the offence. In view of the number of these AEAVs, it can be concluded that they are isolated cases.

The second conclusion that can be drawn from the diagram is that several administrative offence certificates were served without the signature of the required number of witnesses.

Another problem found in the examination of the court decisions is identical to those mentioned above and again concerns the provisions of Article 43 of the LAOP. In the judgment number 375/27.02.2018 of the Plovdiv District Court, a penal decree was annulled in which the refusal of the offender to sign the administrative offence certificate was reflected by the signature of the witness when the offence was established. The Law on Administrative Offences and Penalties, specifically Article 43, paragraph 2, states that the refusal of the offender to sign the administrative offence report shall be evidenced by the signature of a witness. Interestingly, nowhere does this provision of the LAOP state that the witnesses for the establishment of the offence and the witnesses for the refusal to sign the act must be different. The court annulled the penalty order on the ground that the rights of the defence of the penalised party had been violated. An additional problem arises when determining the degree of public danger of the infringement, given that infringements related to fire safety standards are of the formal kind, where no damage or harmful consequences have occurred. The case-law confirms the courts' interpretations of the minority of offences on the basis of paragraph 1(4) of the transitional and final provisions of the Penal Code and Article 93(9) of the LAOP, referring to the insignificance of the harmful consequences or other mitigating circumstances that constitute a lower degree of public danger. Taking the

above findings into account, it should hardly be assumed that all formal offences, as well as those in which no harmful consequences occurred, are minor, which in no way corresponds to the objective reality and to one of the main objectives of the Directorate general of FSCP, namely the prevention of any type of administrative offences which could result in a fire, accident, or property and non-property losses. Another similar example concerns the Plovdiv Regional Court annulment of a penal decree with decision No. 1431/07.08.2018, in which the punished person was sanctioned with a fine under Article 265, paragraph 2 of the Law of Ministry of Interior Act. The fine was imposed due to the established lack of fire extinguishing equipment for initial firefighting. The Court ruled that this offence was of the minor type within the meaning of Article 28 of the LAOP, due to the absence of harmful consequences. A clear legal definition of a minor case should be given in the Ministry of Interior Act or in Regulation 8121h-647/01.10.14, which should correspond to the same definition in the Penal Code, by setting criteria for determining when an offence concerning fire safety should be considered minor.

According to the mass of the examined court decisions of the PDs annulled by the courts, the main reason for the annulment of the penalties is the lack of the requisites under Article 42 and Article 57 of the LAOP. Article 42 of the LAOP provides the content of the required elements of the administrative offence certificate.

On the basis of the examined court decisions, which annul PDs under the mandatory provisions of Article 42 and Article 57 of the LAOP, the results are again mixed. In a large number of cases, the judgments reviewed annulled penal rulings on the basis of Article 42(6) and Article 57(5) of the Penal Code. These are the requisites relating to the circumstances of the offence committed and the correct description of the factual situation. Many PDs are cancelled as unlawful because the draftsman and the administrative punitive authority only mention what has been violated, without a comprehensive description of all the facts and circumstances set out in the text of the legal provision. The reasoning of the court is that it is not sufficient to describe in general terms what has been infringed, but there should be more specificity in the description of the object, whether there are exceptions if the legal provision so stipulates, as well as other facts and circumstances concerning the full coverage of the constituent elements of the administrative offence. In support of the above is the decision No. 1331/25.07.2018 of the Plovdiv District Court, where the violation is cited in the AEAV, in which a fire wall does not have the required fire resistance, as a consequence of which the court annulled the penal decree because the AEAV and the PD did not describe the minimum required fire resistance of the described wall. Another example of such a court decision is again the decision of the Plovdiv District Court No. 818/02.06.2020, in which the act drawer drew up an administrative offence certificate for an offence under



Article 34, paragraph 1 of Regulation No. 8121z-647/2014, pertaining to blocking an escape exit during the operation of a facility. The Court annulled the decree on the ground that the preparer and the administrative sanctioning body had not described how and on which basis the documents in question established that the exit was an evacuation exit.

Another significant problem concerning the mandatory requirements of the LAOP concerning the requisites in the AEA and the PA is the determination of the date of the offence and its detection, i.e. when, how and whether the person committed the offence. There are several such cases, which mainly fall under the Ordinance No. 8121z-968/10.12.2014 on the rules and norms for fire safety when carrying out activities on agricultural land. An example is the decision No. 2113/23.12.16 of the Plovdiv District Court, in which the court referred again to the fact that the evidence implicating the punished person as the perpetrator of the violation was not described.

Two other decisions of the Plovdiv District Court show the revocation of two penalty decrees – one of a natural person and one of a legal person. What is common between the two decisions is the illegality in the drawing up of the AEA of the specific persons. In the first case, an administrative offence notice was issued to a person who had been accepted as the legal successor of a legal person, but this was not established in any way. In the second case, the AEA was drawn up on a natural person who presented himself as the manager of the establishment inspected, but this was not established in any way. In the present case, the substantive law has been infringed and infringements within the meaning of Articles 6 and 7 of the LAOP have been attributed to persons who have no authority concerning fire safety. This is a serious failure in the application of administrative and penal sanctions by the authorities implementing the SFC.

Other problems that were found in the handling of the files and in court decisions were the appealability by the RDFSCP-Plovdiv and the indication of legal assistance and service of legal counsel during the court cases. Regarding the first case, the number of cases in which the Regional Directorate has appealed a decision of the courts is very small. Out of all the decisions of the regional courts, only 6 judgments have been appealed, which only happened over the last 3 years. A serious problem is the fact that the RDFSCP-Plovdiv has only one legal advisor, who does not represent the regional offices in court cases, which plays an extremely important role in the judicial process.

## CONCLUSIONS

Based on everything that has been presented so far, the following conclusions can be drawn:

1. It would facilitate the work of inspectors to introduce a legal definition regarding the cases of "minor offence" in the Law on the Ministry of Interior or in Regulation 8121h-882, whereby in the case of a minor offence, in addition to the already established

possibility in Article 28 of the LAOP, the person should be warned in writing that if he commits another administrative offence of the same type, constituting a minor case, within one year from the entry into force of the warning, an administrative penalty will be imposed for the other offence. It would also be beneficial to provide for the possibility of issuing a non-appealable slip of up to BGN 50 in minor cases, subject to the requirements of the LAOP, as is already the practice established by other administrations.

2. Increase the number of staff carrying out control and/or prevention activities. The increase in staffing will primarily reduce the amount of work for staff members and allow them to focus on quality.

3. Introduce a system of continuous training of the staff in APA, with the participation of lawyers, judges, magistrates, etc.

4. Implement a system for control and analysis of AEAVs and PDs issued. Quarterly monitoring of the APAs of the SFC and PA offices should be carried out. This analysis should be carried out by the legal adviser of the relevant directorate responsible for IDA.

5. Appoint a sufficient number of legal advisors to represent the RDFSCP in any court case and to provide necessary legal assistance and support.

## REFERENCES

The Law on Administrative Offences and Penalties, promulgated in the Official Gazette No. 92 of 28 November 1969, amended in the State Gazette No. 25 of 29 March 2022, supplemented by the State Gazette No. 51 of 1 July 2022.

The Penal Code, published in the State Gazette No. 26 of 2 April 1968, amended and supplemented in the State Gazette No. 53 of 8 July 2022.

Ministry of Interior Act, promulgated in the State Gazette No. 53 of 27 June 2014, amended and supplemented in the State Gazette No. 62 of 5 August 2022.

## BIOGRAPHY

**Nadya Kirilova** was born in Montana, Bulgaria, in 1982. She is a lawyer, with a master's degree in law, and a fire and emergency safety engineer. She works as a senior lecturer at the Bulgarian Academy of the Ministry of Interior, Faculty of Fire Safety and Civil Protection.





ANĐELA JEVIĆ<sup>1</sup>  
MILAN BLAGOJEVIĆ<sup>2</sup>  
VLADIMIR STANKOVIĆ<sup>3</sup>  
DEJAN RISTIĆ<sup>4</sup>  
IVAN GARVANOV<sup>5</sup>

<sup>1,2,3,4</sup> University of Niš,  
Faculty of Occupational Safety  
<sup>5</sup> University of Library Studies and  
Information Technologies,  
Faculty of Information Sciences

<sup>1</sup>andjela.jevtic@znrfak.ni.ac.rs  
<sup>2</sup>milan.blagojevic@znrfak.ni.ac.rs  
<sup>3</sup>vladimir.stankovic@znrfak.ni.ac.rs  
<sup>4</sup>dejan.ristic@znrfak.ni.ac.rs  
<sup>5</sup>i.garvanov@unibit.bg

## ANALYSIS OF SOFTWARE FOR THE CALCULATION OF STANDBY POWER SUPPLY FOR FIRE ALARM SYSTEMS

**Abstract:** Fire detection and alarm systems belong to the class of measurement and information systems that operate in real time, which is why it is vital to calculate the standby power supply in the event of primary power supply interruption. The focus of standby power supply calculation should be on the conditions of the system, primarily on current draw in quiescent and alarm conditions and on the required power supply time, which is defined differently in domestic and international standards. Nowadays, manufacturers of supervision and control panels and of system components (detectors, audio and visual signalling) offer software solutions that considerably facilitate calculations. This paper presents the rules and methods of calculating standby power supply and a comparative analysis of different software used for this purpose, offered by the most renowned manufacturers of fire alarm systems.

**Key words:** fire alarm systems, central unit, detector, standby power supply, loop calculators.

## INTRODUCTION

Fire detection and alarm systems operate in real time and belong to the class of measurement information systems (Blagojević, 2018). Their task is to allow fire detection as early as possible, which would ideally prevent serious losses, threats to human life, and property damage (Blagojević, 2004).

Considering that these systems need to operate constantly, they require a constant power supply. This means that the system power is supplied from a basic, primary source – the public electric power grid – and, in the event of a grid power supply interruption, from a rechargeable battery. The rechargeable battery has to ensure system operation in the absence of the primary power supply for a specified period both in quiescent condition and in alarm condition (Official Gazette of the Federal Republic of Yugoslavia, No. 87/93, 1993). Most standards require that secondary power supply sources ensure 72 hours of operation in quiescent condition and 30 minutes in alarm condition.

The required capacity of the rechargeable battery is determined through calculations that take into account the current draw of each element of the fire detection and alarm system. To simplify the calculation for the standby power supply, manufacturers of fire detection and alarm equipment commonly provide software support for their products. Based on the input data, the software applications, among other things, calculate current draw in quiescent and alarm conditions, which is an important piece of data for determining the required capacity of the rechargeable battery. These are

the so-called loop calculators, the best-known among them manufactured by the companies Hochiki and Apollo (Hochiki, 2022a, Apollo, 2022).

This paper discusses the similarities and differences between the software solutions by Hochiki and by Apollo. The discussion includes the analysis of the advantages and disadvantages of each separate loop calculator, in terms of display and visualization of the calculated data, ease of use, and differences compared to classic calculation methods.

## POWER SUPPLY OF FIRE DETECTION AND ALARM SYSTEMS

Uninterrupted power supply to fire detection and alarm systems is a crucial aspect for the operation of these systems. Accordingly, this field is covered by standards, which define the minimum requirements for power supply.

One of the basic requirements of the European standard EN 54-4: Power supply equipment (SRPS EN 54-4:2011, 2011) is to provide a secondary power supply source, in addition to the primary power grid supply, which needs to ensure system operation if the primary source is interrupted. The primary power supply from the power grid has to ensure continuous system operation but also to provide charging for the rechargeable batteries, which take over the power supply in case of primary source interruption (SRPS EN 54-4:2011, 2011).

Section 6.8.3 Standby Supply of the European standard EN 54-14 states that a standby supply should be

capable of ensuring system operation for at least 72 hours, after which it should have sufficient capacity to power the system in alarm condition for 30 minutes. If immediate notification of failure is an option and a repair service is provided with a repair period up to 24 hours, the minimum standby capacity may be reduced from 72 hours to 30 hours. This period may be further reduced to 4 hours if the spare parts, the repair personnel, and a standby supply from the power grid or a generator are available on site. In addition, battery capacity reduction due to ageing must also be considered, and the initial capacity that is 25% higher than the calculated capacity should suffice (SRPS EN 54-4:2011, 2011).

German standard VDE 0833-2 for standby power supply (DIN VDE 0833-2, 2009) lists the same requirements as EN 54-14, with duration regimes of 72 hours, 4 hours, and 30 minutes. If the 4-hour regime is utilized, the standby supply should be able to maintain system operation for at least 30 hours. The standard provides guidelines for the calculation of standby power supply and prescribes that the initial capacity be 25% higher than the calculated capacity (DIN VDE 0833-2, 2009):

$$K = 1.25(I_1 \cdot t_1 + I_2 \cdot t_2), \quad (1)$$

where:

$K$  – initial capacity [Ah];

$t_1$  – autonomy in quiescent condition [h];

$t_2$  – operation time during alarm condition [h];

$I_1$  – total system current in quiescent condition [A];

$I_2$  – total system current during alarm condition [A].

British standard BS 5839 (BS 5839, 2017) and Russian standard НПБ 88-2001 (NPB 88, 2001) list the same requirements for standby power supply as the European standard – 72 hours in quiescent and 30 minutes in alarm condition. American standard NFPA 72 requires that a primary and a secondary power supply be provided, whereby the secondary power supply has to operate the system for a minimum of 24 hours in quiescent and 15 minutes in alarm condition (Blagojević, 2018).

### Standby power supply calculation

The standby power supply calculation is shown on the example of a hypothetical addressable two-loop fire alarm system.

Loop 1 comprises ten optical smoke detectors, five heat detectors, four manual call points, and two 90 dB wall sounders. Loop 2 comprises eight combined sensors, three manual call points, and two 90 dB wall sounders. Alpha 1100 by QUADEL is the control panel used.

Detectors manufactured by Hochiki were used for the calculation, and the data on their current draw are given in Table 1 (Acorn, 2022a, Acorn, 2022b, Hochiki, 2022b, Hochiki, 2022c, Hochiki, 2022d).

**Table 1.** Current draw of used devices

Type of the fire detection device	Quiescent Current [μA]	Alarm Current [mA]
Optical smoke detector	400	17.5
Combined heat and rate of rise detector	350	19.5
Multisensor	450	19.5
Hochiki call point	220	5
Wall sounder	150	6.5

Loop 1

Quiescent current:

$$I_{p1} = 10 \cdot 400 \mu\text{A} + 5 \cdot 350 \mu\text{A} + 4 \cdot 220 \mu\text{A} + 2 \cdot 150 \mu\text{A} \quad (2)$$

$$I_{p1} = 6.930 \text{ mA}. \quad (3)$$

Total alarm current:

$$I_{p1,AL} = 10 \cdot 17.5 \text{ mA} + 5 \cdot 19.5 \text{ mA} + 4 \cdot 5 \text{ mA} + 2 \cdot 6.5 \text{ mA} \quad (4)$$

$$I_{p1,AL} = 305.5 \text{ mA}. \quad (5)$$

Loop 2

Quiescent current:

$$I_{p2} = 8 \cdot 450 \mu\text{A} + 3 \cdot 220 \mu\text{A} + 2 \cdot 150 \mu\text{A} = 4.56 \text{ mA}. \quad (6)$$

Total alarm current:

$$I_{p2,AL} = 8 \cdot 19 \text{ mA} + 3 \cdot 5 \text{ mA} + 2 \cdot 6.5 \text{ mA} = 180 \text{ mA}. \quad (7)$$

Control panel current in quiescent condition is  $I_{cen(MS)} = 70 \text{ mA}$  (Quadel, 2013).

Total system current in quiescent condition is

$$I_p = I_{p1} + I_{p2} + I_{cen(MS)} = 0.08149 \text{ A}. \quad (8)$$

The required battery capacity for operation in quiescent condition over 72 hours is

$$C_{MS} = 72 \text{ h} \cdot I_p = 5.8673 \text{ Ah}. \quad (9)$$

In alarm condition, the control panel current is  $I_{cen(AL)} = 90 \text{ mA}$  (Quadel, 2013).

Total system current in alarm condition is

$$I_A = I_{p1,AL} + I_{p2,AL} + I_{cen(AL)} = 0.5755 \text{ A}. \quad (10)$$

The required battery capacity for operation in alarm condition over 30 minutes is

$$C_{AL} = 0.5 \text{ h} \cdot I_A = 0.28775 \text{ Ah}. \quad (11)$$

The total standby supply capacity for operation over 72 hours in quiescent and 30 minutes in alarm condition is

$$C = 1.25(C_{MS} + C_{AL}) = 7.694 \text{ Ah}. \quad (12)$$

The available battery capacities (2·12 V) for placement inside the control panel are 7 and 12 Ah.

According to the calculations, the battery capacity of 12 Ah is selected.

All the necessary parameters for the calculation of standby power supply can be obtained in a simpler manner using different software applications designed for this purpose. The following sections focus on the calculation of standby power supply using two different software applications – the Hochiki Loop Calculator and the Apollo Loop Calculator.

### Hochiki Loop Calculator

The Hochiki Loop Calculator allows users to select the control panel, cable type, and fire detection device, and then make various calculations, such as Total Alarm Current, Quiescent Current, Total Current (low power mode), and Maximum length of cable. The first step is to select the control panel, which is done in the Panel Editor, and the type of installation cable, which is done in the Cable Editor. It is possible to select only one of the available options, but there is also the option for users to customize the control panel and the cable type.

Based on the number of loops supported by the selected control panel, predicted elements for each loop are input. The main window contains the list of all fire detection devices (sensors, call points, sounders), the field to input the number of loop elements, and the quantities obtained by the calculation.

Figure 1 shows the report for Loop 1 obtained from a calculation in the Hochiki Loop Calculator.

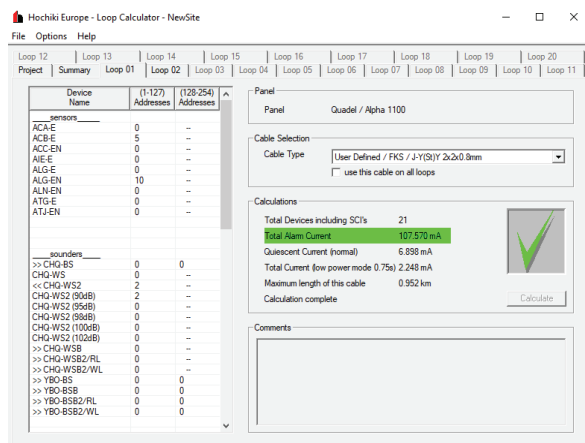


Figure 1. Loop 1

Comparison of the values obtained from the above calculation suggests that the current in quiescent condition (Quiescent Current) in the Loop Calculator has an almost identical value to the current obtained from the classic calculation method. Nevertheless, the values obtained for the current in alarm condition (Total Alarm Current) differ significantly. Loop Calculator calculation yielded a considerably lower current value than the classic calculation.

Namely, calculation of alarm current was made under the assumption that all detectors in the loop will be in alarm condition, so a higher value of the current in

alarm condition was obtained, which was also expected for the Loop Calculator calculation. However, based on multiple calculations made in the Loop Calculator, it was established that, when calculating the alarm current, it does not assume that all detectors in the loop are in alarm condition but that their number should not exceed five.

Under the assumption that a total of three detectors will be in alarm condition, two optical smoke detectors and one heat detector, the calculation is as follows:

Quiescent Current:

$$I_p = 2 \cdot 400 \mu A + 1 \cdot 350 \mu A = 1.15 \text{ mA} \quad (13)$$

Total Alarm Current:

$$I_{pAL} = 2 \cdot 17.5 \text{ mA} + 1 \cdot 19.5 \text{ mA} = 54.5 \text{ mA} \quad (14)$$

The Loop Calculator calculation for the given setup is shown in Figure 2.

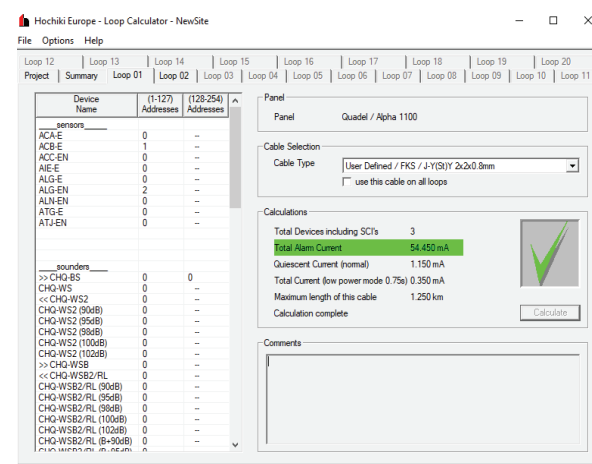


Figure 2. Current in alarm condition

It is evident that the three detectors yield the same current value in alarm condition, both from the classic and the Loop Calculator calculation.

For any number of detectors in the alarm over 5, the current value in alarm condition in the Loop Calculator is lower than with classic calculation, as shown in the following example. Let us assume that the alarm contains three optical smoke detectors and three heat detectors.

Quiescent Current:

$$I_p = 3 \cdot 400 \mu A + 3 \cdot 350 \mu A = 2.25 \text{ mA} \quad (15)$$

Total Alarm Current:

$$I_{pAL} = 3 \cdot 17.5 \text{ mA} + 3 \cdot 19.5 \text{ mA} = 111 \text{ mA} \quad (16)$$

The Loop Calculator calculation for this example is shown in Figure 3.

The difference in current value in alarm condition can be explained by the fact that it is practically impossible for all detectors to be in alarm condition simultaneously. However, the absence of user instructions could be considered the main disadvantage

of this type of calculator when solving problems similar to this one.

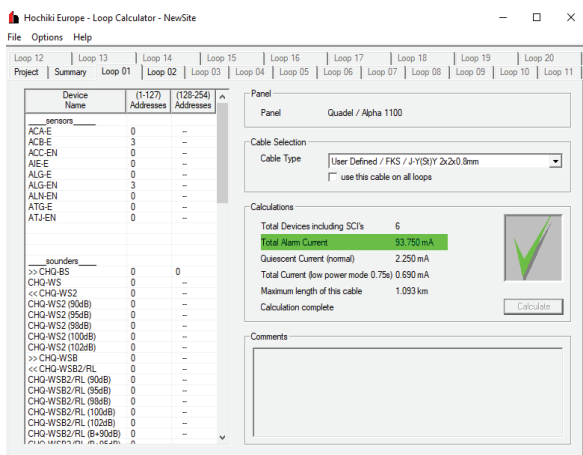


Figure 3. Calculation example

Naturally, the number of detectors in alarm condition will depend on the topology of the building under protection, so any considerations regarding the number of detectors in alarm condition are purely general. One of the advantages of the Hochiki Loop Calculator is its ease of use and good data visualization.

### Apollo Loop Calculator

The Apollo Loop Calculator is another loop calculator with similar features as the Hochiki Loop Calculator. This calculator is used to calculate voltage drop for a given loop, maximum cable runs, or minimum cable sizes. The calculation considers the properties of the control panel and the cable, which is why, as in the case of the previous calculator, it is first necessary to select the control panel.

Based on the number of loops designated for the selected control panel, there is an option to input data for each loop. Figure 4 shows the appearance of the Apollo Loop Calculator user interface with the Elite RS control panel by Kentec Electronics. This control panel can be configured for up to two detection loops.

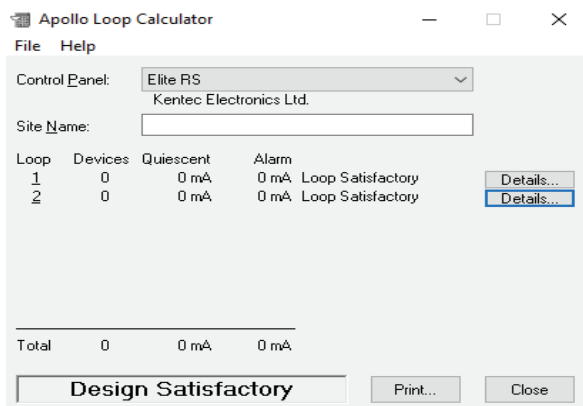


Figure 4. Appearance of the user interface

The main window of the Apollo Loop Calculator is used for the input of loop elements. The quiescent and

alarm currents are displayed for the selected number of detectors. It is also possible to view the current draw for each selected detector separately as well as the total current. This calculator requires users to select the type of calculation to be made (Max Volt Drop, Max Cable Run, or Min Cable Size), based on which the necessary parameters are assigned.

Such an approach may be at a disadvantage compared with the Hochiki Loop Calculator, in which the calculation is triggered by detector selection. In addition, calculation results in the Hochiki Loop Calculator have superior visualization.

The appearance of Loop Data window is shown in Figure 5.

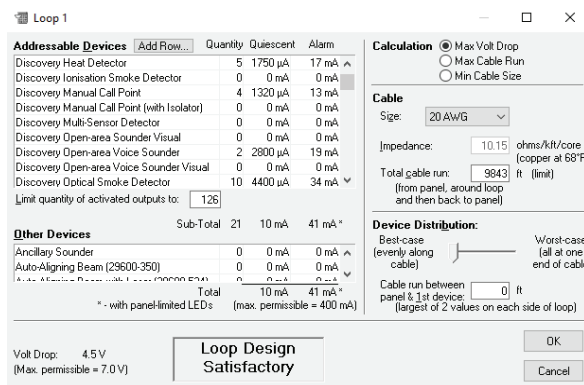


Figure 5. Loop Data window

After all the loop elements have been selected, the main window displays quiescent and alarm currents for each separate loop as well as the total current (Figure 6).

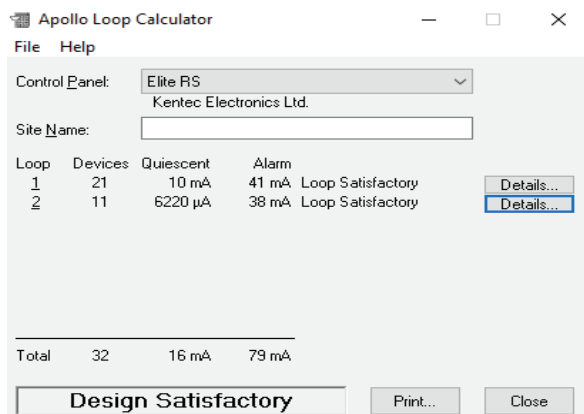


Figure 6. Current in quiescent and alarm condition

The chief advantage of the Apollo calculator over the Hochiki one is the detailed user instructions. It is particularly significant that it provides explanations for the predefined parameters the calculator uses to make calculations, considering the fact that if any of the parameters for a calculated loop are inadequate, the calculation will be incorrect.

## CONCLUSION

A comparative analysis of the Hochiki Loop Calculator and the Apollo Loop Calculator software showed that both applications operate similarly, with slight differences in the manner of data display. How the software will be used depends on the type of fire detection devices used, since device specifications vary among different manufacturers.

The Hochiki Loop Calculator has a slight advantage in terms of data visualization. Nevertheless, even though it is fairly easy to use, users still need to become thoroughly familiar with its usage without any usage instructions.

On the other hand, the Apollo Loop Calculator has a slightly more complicated user interface but provides users with detailed usage instructions.

Generally, use of software for standby supply calculations has many advantages over the classic calculation method. The main advantage is the reliability of software calculation, as the probability of an error is much higher in classic calculation. Likewise, using software will considerably reduce the time required for calculation compared to the classic approach, especially for systems with a large number of loops.

## REFERENCES

- Acorn. (2022a). *Optical Smoke Detector, Specifications*, [online], available at: <https://www.acornfiresecurity.com/pdf/data/ALG-EN.pdf>.
- Acorn. (2022b). *Combined Heat and Rate of Rise Sensor, Specifications*, [online], available at: <https://www.acornfiresecurity.com/pdf/data/Hochiki/Hochiki%20-%20ACB-E%20Multi-heat%20sensor%20Datashet.pdf>.
- Apollo. (2022). *Apollo Loop Calculator*, [online], available at: <https://www.apollo-fire.co.uk/training-support/tools/loop-calculator/loop-calculator-thank-you/>.
- Blagojević, M. (2018). *Projektovanje sistema za dojavu požara*, Belgrade: AGM knjiga.
- Blagojević, M., Ristić, J., Simić, Đ. (2004). *Sistemi za otkrivanje i dojavu požara*, Niš: Faculty of Occupational Safety in Niš.
- BS 5839. (2017). *Fire detection & alarm systems for buildings*, [online], available at: <https://www.fia.uk.com/resources/british-standards/bs-5839-series.html>.
- DIN VDE 0833-2. (2009). *Alarm systems for fire, intrusion and hold up – Part 2: Requirements for fire alarm systems*, [online], available at: <https://www.vde-verlag.de/standards/0833013/din-vde-0833-2-vde-0833-2-2009-06.html>.

Hochiki. (2022a). *Hochiki Europe Loop Calculator*, [online], available at: <https://www.hochikieurope.com/software>.

Hochiki. (2022b). *Multisensor, Specifications*, [online], available at: [http://www.hochikiaustralia.com/media/uploads/documentdownloads/ACA-E\\_SpecificationHAUv2.pdf](http://www.hochikiaustralia.com/media/uploads/documentdownloads/ACA-E_SpecificationHAUv2.pdf).

Hochiki. (2022c). *Hochiki Callpoint, Specifications*, [online], available at: [http://www.hochikiaustralia.com/media/uploads/documentdownloads/HCP-E\\_Specification.pdf](http://www.hochikiaustralia.com/media/uploads/documentdownloads/HCP-E_Specification.pdf).

Hochiki. (2022d). *Wall Sounder, Specifications*, [online], available at: [https://hochiki.chorus.thirdlight.com/link/CHQ-WS2\\_Specification.pdf/@/preview/1?o](https://hochiki.chorus.thirdlight.com/link/CHQ-WS2_Specification.pdf/@/preview/1?o).

NPB 88. (2001). *Fire-extinguishing and alarm systems*, [online], available at: <https://www.russiangost.com/p-19278-npb-88-2001.aspx>.

Quadel. (2013). *Uputstvo za projektovanje, Analogni adresibilni sistemi za dojavu požara*, [online], available at: [http://www.quadel.rs/media/pdf/Uputstvo\\_za\\_adresibilne.pdf](http://www.quadel.rs/media/pdf/Uputstvo_za_adresibilne.pdf).

Official Gazette of the Federal Republic of Yugoslavia, No. 87/93. (1993). *Pravilnik o tehničkim normativima za stabine instalacije za dojavu požara*, available at: [https://www.pravno-informacioni-sistem.rs/SIGlasnikPortal/eli/rep/slsrj/drugidrzavniorga nizacije/pravilnik/1993/87/1/reg](https://www.pravno-informacioni-sistem.rs/SIGlasnikPortal/eli/rep/slsrj/drugidrzavniorganiorga nizacije/pravilnik/1993/87/1/reg).

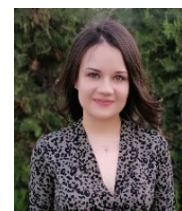
SRPS EN 54-4:2011. (2011). *Sistemi za detekciju požara i požarni alarmni sistemi – Deo 4: Oprema za napajanje*, [online], available at: [https://iss.rs/sr\\_Cyrl/project/show/iss:proj:22980](https://iss.rs/sr_Cyrl/project/show/iss:proj:22980).

## ACKNOWLEDGEMENTS

This research was supported by the Ministry of Education, Science and Technological Development of the Republic of Serbia.

## BIOGRAPHY of the first author

**Andela Z. Jevtić** Andela Z. Jevtić was born in Prokuplje, Serbia, in 1998. She received her bachelor's degree in occupational safety at the Faculty of Occupational Safety in Niš. She also finished master's degree on Faculty of Occupational Safety in Niš, in study programme Fire Safety Engineering. She is currently a PhD student at the same faculty.







KIRIL HRISTOV<sup>1</sup>  
RADOSLAV KURTOV<sup>1</sup>  
VERONIKA KARADJOVA<sup>2</sup>

<sup>1</sup>Academy of Ministry of Interior,  
Faculty of Fire safety and civil  
protection

<sup>2</sup>University of Chemical Technology  
and Metallurgy, Sofia, Bulgaria

kiko\_h@abv.bg  
r\_kurtov@abv.bg  
vkaradjova@uctm.edu

## ANALYSIS OF LAMINATED PVB GLASSES APPLIED IN THE CONSTRUCTION INDUSTRY

**Abstract: Introduction:** Many glass-based materials are nowadays used in the construction industry thus allowing an increase in the energy efficiency of buildings and reduction of maintenance costs, as well as minimization of toxic products released under fire. This communication addresses the basic characteristics of laminate glasses using a layer of polyvinyl butyral (PVB) and their applicability as elements in building constructions. The existing situation considering the fire safety at the building design level and consequent construction work applying laminated PVB glasses and the EU regulatory requirements has been analyzed.

**Key words:** laminated glass, polyvinyl butyral (PVB) layer, fire safety, fire

### INTRODUCTION

Glass finds an ever-greater application and a leading position as a construction product in modern architecture. It gains a central position as a structural element – non-carrying walls, fences, facades, roof covers, doors, linings, etc.

Glass is an ecological and recyclable material, economically expedient, classified as a product, which is non-burning and non-spreading the burning. At the same time, the glass elements in every project have two important characteristics – the level of light transmission and weight. The innovations in glass production are focused on increasing energy efficiency via the practical and aesthetic qualities of glass products. They create the impression of lightness, freedom, luxury, and richness of space, due to which it is used more and more when designing the interior of both residential, as well as public buildings.

It is very important to point out that the use of glass as a construction product must be in accordance with the requirements of fire safety in residential, public, and industrial buildings.

In its structure, as it is known, glass is an amorphous solid body, which is pliable, but in its final form it has weak impact resistance, in other words, it is a fragile material, and it breaks into large, serrated pieces with sharp edges. Nowadays, in order to prevent the spreading of dangerous pieces in the occasion of an impact and in the occasion of reaction to a fire, laminated glass is produced, one which results from the combining of two or more layers of regular float glass with a plastic inner layer (fig. 1), usually made of PVB.

Depending on the structure (the number of glass sheets and transitional layers), different levels of safety and isolation can be guaranteed. Laminated (coated) glass can be used as monolith glass or in double glazing.

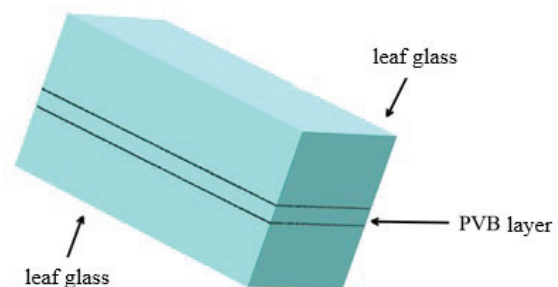


Fig. 1 Structure of coated, multi-layer glass with a PVB layer

The main advantage of coated glass is to do with its safety. Normal glass is fragile and it is shattered into long sharp pieces which cause serious and sometimes fatal injuries, especially in the case of fire. The main function of the coated glass is that its medium layer absorbs the energy of the heat and in this way, the layers of the glass stay connected to one another thus lowering the risk of injuries to a minimum.

Other advantages to the multi-layer glass with a PVB layer are security (prevents breaking and entering), control of discoloration (absorbs the ultraviolet rays of the sun while at the same time it allows for the visible light to go through it), climate control (for heat isolation and lowering of heating expenses), exterior and interior application (it can be produced with a wide array of colored folio in order to glaze floors, staircases, balconies, balustrades, interior and exterior linings, doors and windows), etc.

All these advantages predetermine the wide application of multi-layer glass with a PVB layer - For glazed entryways and interior doors, protective glazing for

museums banks prisons shops and others; for the production of skylights, solar panels, for the production of smoke and other partitions; for the cover glazing of office buildings, Shopping centers, hotels, etc; for noise isolated spaces, for fire safety purposes.

### ANALYSIS OF THE NORMATIVE DOCUMENTS REGULATING THE USE OF COATED PVB GLASS IN THE REPUBLIC OF BULGARIA AND OTHER COUNTRIES

When designing buildings architects are faced with a variety of challenges - ensuring the mechanical resistance of the building; restrictions for construction on the land; Ensuring accessibility and safety during exploitation; ensuring noise protection; saving energy and heat. An additional challenge is generated by the constant opposition between compliance with the normative requirements for fire safety and satisfying the Investment intentions of the contractor. This enormously difficult task is impossible without the intervention of specialists, who have the knowledge of the types of construction materials and their condition during a fire, The condition of the building structures under fire pressure, the characteristics of the different types of fires, behavior of thermodynamic and convective flow, and last but not least, the state requirements in the area of fire safety.

The main requirements in Bulgaria to ensure fire safety are outlined in Ordinance № Iz-1971 for construction and technical rules and norms to ensure fire safety during a fire. The ordinance is applied simultaneously with the requirements of normative acts For the volume and consistency of the structural schemes and plans, the rules and regulations for the development of the territory, the norms rules and technical specifications for designing and execution of the buildings, as well as the normative requirements for coordination, approval, permission and initiating the buildings in exploitation.

In order to ensure safety during a fire, the building needs to be designed and executed in such a way that: the resistance of the construction is insured for a certain period of time; measures are taken to limit the occurrence and spreading of fire and smoke in the building; measures are taken against its spreading towards neighbouring buildings; conditions are ensured for the residents to be able to leave the building or to be saved via other means; conditions for the safety of the rescue teams to be created.

The building structures and elements of the buildings are designed with fire resistance, which satisfies the applicable criteria for - Carrying capacity (R), Impenetrability (E), and Isolating capacity (I). Building elements and constructions are classified in terms of their fire resistance in accordance with the standard Bulgarian National Standard (BNS) EN 13501-2:2016 [2] and the Decisions of the European Commission on fire resistance classification, published in the "Official Journal" of the European Union.

According to the requirements for minimum fire resistance of the structural elements for buildings from I to IV degree, there is a set criterion for the structural elements - for columns, frames, platforms and arms of stairs from R 15 to R 180; for external and internal non-bearing walls, walls of staircases and walls of evacuation corridors and lobbies from EI 15 to EI 120 and respectively for inter-floor partition structures, external and internal load-bearing walls from REI 15 to REI 180.

For Grade V buildings, according to Ordinance № Iz-1971 [1], fire resistance of its structural elements is not required, therefore it is permissible to implement non-load-bearing walls, partitions, facades, roof coverings from laminated multilayer glass with a PVB layer. In order to make possible the wider application of building structures and elements made of PVB glasses, it is essential to determine a criterion for fire resistance only by testing in accordance with European standards.

Another main indicator for assessing the degree and contribution to the spread of fire and for classifying construction products is the class of reaction to fire, which is determined on the basis of test results. Construction products are classified according to their reaction to fire in accordance with BNS EN 13501-1:2019 [3].

The building glass products are a class of reaction to fire (CRF) A1, which is a non-combustible product that does not contribute to the development of uncontrolled combustion, such as laminated multi-layer glass with a PVB layer, and for them, no testing is required.

According to Ordinance № Iz -1971 [1], glazings (except for those in external facade walls) are provided with a class of reaction to fire not lower than that required for the products for covering the corresponding internal surfaces, and glazings in fire protection partitions - with fire reaction class not lower than A2, in which case PVB glasses fully meet the above requirements.

When designing glazed areas along the entire height of the facade (double facade), it is appropriate to use laminated glass with a PVB layer, but provided that horizontal and vertical protection is provided according to fig. 2.

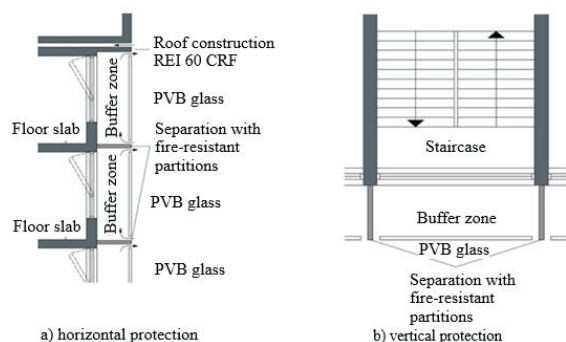


Fig. 2. Horizontal (a) and vertical (b) protection in the use of laminated glass for a double facade

Another key point in securing buildings is ensuring safe evacuation in case of fire. In Ordinance № Iz -1971 [1], evacuation through an adjacent room is permissible, if an evacuation exit(s) is provided from the interior room to only one adjacent room when the interior room is intended for no more than 50 people, and the length of the evacuation route from the farthest point in the interior room to a final evacuation exit is no more than 20 m and for the rooms, glazing with an area of at least 0,1 m<sup>2</sup> is provided in the door(s) or the wall between the two rooms, which provides a direct view of the occupants from the interior to the adjacent room. The use of laminated multi-layer glass with a PVB layer in this case is an appropriate architectural solution.

It is allowed to design doors between evacuation staircases and corridors (floor lobbies) with reinforced or plain glass with a thickness of not less than 5 mm or with double-glazed windows, and when glazing the doors with plain glass in constructions for public service in the field of education and in constructions for public service in the field of culture and art, glasses must be secured against disintegration when broken. The provision of glazing with PVB glasses will fully satisfy the above requirements to ensure the safety of the residents.

The use of laminated glass is also suitable when separating the evacuation stairs into stairwells, through glass walls and doors when accessing from lobbies, corridors and terraces, and in tall buildings with a height of 28 to 75 m, when access is only to corridors, vestibules and vestibule. The evacuation stairs must be naturally lit by means of facade glazing with an area not less than 5% of the built-up area of the stairwell. When it is not possible to design facade glazing for the evacuation staircase, it is accepted as internal according to Ordinance № Iz -1971 [1], then direct overhead lighting with an area of at least 4 m<sup>2</sup> is allowed for some types of buildings. Since the staircase is an escape route from the building, it is recommended to use laminated glass with a PVB layer to prevent sharp pieces from falling on the occupants in case of glass breakage.

The next elements of the escape routes are the corridors, which must be filled with walls with certain fire resistance. Provided that the corridor is glazed with PVB glasses and the same is without the necessary fire resistance, the glazed section must be between two final evacuation exits and the evacuation route from the stairs should not pass through it, and for the floors without direct exits on the elevated terrain - glazing a section of the corridor must be between two escape staircases separated from the floor level by firewalls.

In buildings with an atrium, the glazing and other transparent coverings in the roof part of the atrium are provided with a CRF not lower than A2, and as already said laminated multi-layer glass with a PVB layer is classified as a product with CRF A1 and fully fulfills the intended requirement.

From what has been presented so far, the possibility of wide application of laminated multi-layer glass with a PVB layer in Bulgaria is clearly visible, as a construction product fully covering the clearly regulated requirements for ensuring the fire safety of buildings. The scope of use can of course be extended, but after carrying out research and tests to carry out a classification of the relevant types of PVB glasses in terms of their fire resistance in case of fire.

The main normative document in Poland, which lays down rules for ensuring fire safety in the design and construction of buildings, is the Ordinance of the Minister of Infrastructure of April 12, 2002, on the technical conditions to which buildings must comply and their location [4]. The projects that are necessarily subject to coordination with the competent authorities for fire protection are regulated in the Ordinance of the Minister of the Interior and Administration of September 17, 2021, for the coordination of a project for the development of a plot or land, architectural and construction project, technical project and design of a fire-fighting facility, regarding compliance with fire protection requirements [5] issued on the basis of the Fire Protection Act [6].

The Law on Fire Protection defines the procedure for evaluating the installed products, which must meet the standards in force in Poland, and the specific requirements for CRF of the same in the additions to the Ordinance of the Minister of Infrastructure dated April 12, 2002 [4].

Every building and its associated equipment must be designed and executed so that the following conditions are met: Retention of load-bearing capacity of the structure in case of fire, for the time specified in the ordinance; Limiting the spread of fire and smoke in the building; Limiting the spread of fire to neighboring buildings; Ensuring the safe evacuation of people. In the Ordinance of April 12, 2002 [4], five classes of fire resistance of the building are defined - A, B, C, D and E, with a criterion for fire resistance of the structural elements of the building from R 15 to R 240, from REI 30 to REI 120, from EI 15 to EI 120, and the fire resistance criteria for the roof covering are defined from RE 15 to RE 30, respectively.

According to the requirements for the minimum fire resistance of structural elements of buildings, only for buildings of fire resistance class D and E it is permissible to perform internal non-load-bearing walls, partitions and roof coverings of laminated multi-layer glass with a PVB layer, and for buildings of class E it is allowed and for exterior non-bearing walls and facades.

The requirements for the fire-resistance criteria of structural elements, on the basis of which the class of buildings is determined, do not apply to roof glazing, skylights, skylights and lattice windows, if the openings in the slope of the roof do not cover more than 20% of its surface, i. e. these glazings are not required to meet the given fire-resistance criterion, but

they must be of increased impact resistance. This allows the use of PVB glasses in the execution of roof glazing, skylights, skylights and lattice windows.

According to the standard PN-EN 13501-1: 2019 [7] in the Ordinance of April 12, 2002 [3] classes of reaction to fire of the construction products are also defined, which are A1, A2, B, C, D, E and F.

In the case of some public and residential buildings, it is allowed to reduce the fire resistance class by one compared to the legally required one, if they are equipped with stationary fire extinguishing systems. For a one-story production building with a combustible load of more than 500 MJ/m<sup>2</sup>, which is made of building products with CFR A1 or A2 and for which a smoke and heat exhaust ventilation system (SHEVS) is built, it is allowed to be of fire resistance class E. These exceptions in the design of the buildings give freedom to the designers to bet on the use of laminated glass in the construction.

The implementation of glass facades with multi-layered glass is allowed for buildings over 25 m high, as glass is a non-combustible product and has increased impact resistance, but on the condition that the fastening elements are also non-combustible.

Another possible application of laminated multi-layer glass with a PVB layer is for the glazing of door wings, but when using transparent and semi-transparent glasses, they must also be visibly marked. In the construction of glass railing elements, according to the Ordinance of April 12, 2002 [4], they must be made of glass with high resistance to impact and breakage, where it is appropriate to use laminated glass with a PVB layer.

Normative requirements in Poland largely limit the possibility of wide application of the considered laminated glasses. There are requirements for fire resistance of the elements of evacuation routes in residential and some public buildings - walls and partitions, but nevertheless, it is possible to reduce the fire resistance class of certain buildings when designing active fire safety measures, which in turn is a compensatory measure. Such measures, which permit the reduction of passive fire safety requirements, at the expense of anticipating active measures, enable architects to apply different engineering approaches in the design process.

The study of the regulations regarding the provision of fire safety in the design of buildings in Greece showed a limited application of the use of construction products and in particular of laminated glass. The main regulatory document defining the requirements and measures for fire safety is the Ordinance on Fire Protection of Buildings, promulgated by Presidential Decree 41/2018 [8].

The Ordinance on Fire Protection of Buildings [8] regulates the requirements and measures that must be taken in buildings in order to: protect the life and health

of the people who are in them in the event of a fire; prevent the spread of fire from the place where it originated to other parts of the building; prevent the spread of fire from the place of origin to neighboring buildings; protect the buildings themselves and their equipment.

The main criterion is the fire resistance of the building, which refers to load-bearing and non-load-bearing structural elements, walls of evacuation routes, as well as fire barriers that are expected to be exposed to fire during the stage of a fully developed fire. In this case, the main purpose of fire protection is to limit the fire to the area (or building) from which it started, as well as to prevent damage to the structure.

Despite the trends for the entry of glass products in construction, the Ordinance on Fire Protection of Buildings [8] largely limits their use. According to their purpose, the buildings must be designed to cover the required minimum fire resistance index for the whole building - from 30 to 240 minutes, as well as the required fire resistance indicators of the structural elements - REI, R and EI.

The fire resistance index of a structural element is determined in accordance with the fire resistance tests according to standard EN 13501-2:2016 9 and refers to multiple criteria. Generally, however, the term fire resistance means satisfying the following three criteria: stability (R), integrity (E) and resistance to heat transfer (I). The necessary criteria - indicators of fire resistance of the structural elements that must be observed are: For load-bearing masonry (external and internal), dividing structural elements of floors - fire barriers (plates and beams) and self-supporting roof coverings (panels, etc.) - REI; For supporting vertical elements (columns, walls, frames, etc.) and supporting elements of stairs - R; For external non-load-bearing masonry, fire doors, windows, showcases, fire escape walls, fire compartment walls and staircase walls - EI.

From what has been analyzed so far, it is clear that the Ordinance on Fire Protection of Buildings [8] does not set requirements for fire resistance criteria for internal non-bearing walls, internal partitions, railings, balconies, windows and doors of premises for which fire resistance is not required, as and for glass facade cladding. This makes it possible to use laminated glass with a PVB layer in the construction of buildings in Greece.

## CONCLUSIONS

And give an assessment of the main requirements for ensuring fire safety during the designing and execution of buildings with the use of coated glass with an intermediary PVB layer in compliance with the normative requirements, the following conclusions can be drawn:

- In Bulgaria and in other countries Regulations for ensuring the resistance of the buildings during a fire



and criteria for a level of the burning of their constructive elements are submitted, from which requirements it can clearly be seen how widespread the possibilities for application of coated glass is when designing buildings - for dinner non-carrying walls, internal partitions, railings, balconies, glass ceilings, room doors, glass facades, etc.

- The provision of active measures to ensure fire safety (automatic fire alarm systems, smoke and heat exhaust ventilation systems, automatic fire extinguishing systems, or combinations thereof) in order to reduce the requirements for passive protection is an approach that can be applied as a compensatory a measure in the building design process to ensure their fire safety. This would lead to the wider application of PVB-coated glass in construction.
- The accurate assessment of the burning pressure of the buildings by the engineers has to be given as an important criterion during the assessment of the capabilities of the partitions to prevent the spreading of burn waste along the way for evacuation, as well as the possibility to use coated glass with an intermediary PVB layer in this case.
- In the designing process the participation of specialists in fire safety, who can skillfully assess and assist the investors in their choice and type of undertaking of construction products of PVB glass is evermore necessary.

With regard to the drawn conclusions, it is necessary to undertake steps in the direction of the continued research with PVB glass in order to achieve the criteria for fire resistance, as well as perfect the thermic resistance of the transitional layer, which would allow to spread the application of this type of glass with the goal of fire safety.

## REFERENCES

Наредба №Из-1971 за строително-технически правила и норми за осигуряване на безопасност при пожар от 29.X.2009 г. [Ordinance № Iz-1971 for construction and technical rules and norms to ensure fire safety during a fire from 29.X.2009].

БДС EN 13501-2:2016 Класификация на строителни продукти и елементи по отношение на реакцията им на огън. Част 2: Класификация въз основа на резултати от изпитвания на устойчивост на огън с изключение на вентилационни инсталации [BNS EN 13501-2:2016 Fire classification of construction products and building elements - Part 2: Classification using data from fire resistance tests, excluding ventilation services].

БДС EN 13501-1:2019 Класификация на строителни продукти и елементи по отношение на реакцията им на огън. Част 1: Класификация въз основа на резултати от изпитвания на реакция на огън [BNS EN 13501-1:2019 Fire classification of construction products and building elements - Part 1: Classification using data from reaction to fire tests].

Dz.U. 2002 nr 75 poz. 690 Rozporządzenie Ministra Infrastruktury z dnia 12 kwietnia 2002 r. w sprawie warunków technicznych, jakim powinny odpowiadać budynki i ich usytuowanie [Journal of Laws 2002 No.75, item. 690 Regulation of the Minister of Infrastructure of 12 April 2002 on technical conditions to be met by buildings and their location].

Dz.U. 2021 poz. 1722 Rozporządzenie Ministra Spraw Wewnętrznych i Administracji z dnia 17 września 2021 r. w sprawie uzgadniania projektu zagospodarowania działki lub terenu, projektu architektoniczno-budowlanego, projektu technicznego oraz projektu urządzenia przeciwpożarowego pod względem zgodności z wymaganiami ochrony przeciwpożarowej [Journal of Laws 2021 item 1722 Regulation of the Minister of the Interior and Administration of September 17, 2021 on the reconciliation of the plot or land development design, architectural and construction design, technical design and design of a fire protection device in terms of compliance with fire protection requirements].

Dz. U. 1991 Nr 81 poz. 351 USTAWA z dnia 24 sierpnia 1991 r. o ochronie przeciwpożarowej, Opracowano na podstawie: t.j. Dz. U. z 2021 r. poz. 869, 2490 [Journal Of Laws 1991 No. 81, item 351 ACT of August 24, 1991 on fire protection, Prepared on the basis of: i.e. Journal Of Laws of 2021, item 869, 2490].

PN-EN 13501-1:2019 Klasyfikacja ogniowa wyrobów budowlanych i elementów budynków – Część 1: Klasyfikacja na podstawie badań reakcji na ogień [PN-EN 13501-1: 2019 Fire classification of construction products and building elements - Part 1: Classification based on reaction to fire tests].

Π.Δ. 41/2018 Κανονισμός Πυροπροστασίας Κτιρίων [P.D. 41/2018 Building Fire Protection Regulation].

ISO 12543-1:2021 Glass in building — Laminated glass and laminated safety glass — Part 1: Vocabulary and description of component parts.

EN 13501-2:2016 Fire classification of construction products and building elements - Part 2: Classification using data from fire resistance tests, excluding ventilation services.

EN 13501-1:2018. Fire classification of construction products and building elements - Part 1: Classification using data from reaction to fire tests.

## BIOGRAPHY of the first author

**Kiril Hristov** was born in Samokov, Bulgaria, in 1982.

He is an assistant in the Academy of the Ministry of Interior, Faculty of Fire safety and civil protection. His research interests are in the field of ventilation and fire safety in buildings.





VASIL TSANOV<sup>1</sup>  
RADOSLAV KURTOV<sup>2</sup>

<sup>1,2</sup> Academy of the Ministry of  
Interior,  
Faculty of Fire Safety and Civil  
Protection,  
Sofia, Bulgaria

<sup>1</sup>vasil.tsanoff@tsanoff-classic.com  
<sup>2</sup>r\_kurtov@abv.bg

## SEMI-EMPIRICAL METHODS FOR DETERMINING CRITICAL TEMPERATURE

**Abstract:** *This report presents an adapted methodological scheme for theoretical determination of critical temperature. It is based on redefined Lydersen's thermodynamic method (1955) and its subsequent adaptations by Ambrose (1978), Klineciewicz (1984), Joback (often named the Joback-Reid method) (1987) and Gani-Constantinou (1994). Assuming that the critical temperature for a pure substance is the temperature above which the gas cannot become liquid, regardless of the applied pressure, the implication is that some of the calculated thermodynamic quantities can be used (after their didactic research and proof) and/or be replaced with empirical ones. The algorithm of each of the studied methods passes through a numerical value of the boiling point. It is this value that can be replaced by an empirically measured one. In addition to the final result of the critical temperature, the already predefined variables are checked, such as ionization potential, LogP, Gibbs free energy, heat of formation, ideal gas thermal capacity and molar refractivity. This is done by analyzing the values of entropy, enthalpy, and energy of absolute zero. The experiment was conducted in an environment of GAMESS US and MOPAC using their scripting languages. The analysis of the results is performed using OriginLab and R. Conclusions: The studied values in the adapted semi-empirical methodological schemes reach the accuracy of  $R^2 \approx 0.94$ .*

**Key words:** critical temperature, semiempirical methods, statistical thermodynamics

## INTRODUCTION

Measuring critical values (Stanley, 1947) for volume, pressure and temperature is a slow, complex and expensive process. At the same time, the repeatability of the results is not always good (Berche, 2009), due to the sensitivity of the methodologies to individual factors – purity of the compounds, isolation of the environment, processes of intermolecular interactions, etc.

In the modern technological world, thousands of new substances and materials are created every year. Molecular design, in turn, has developed to the point of producing materials with precisely defined, predetermined properties. This also applies to flame retardant materials. By means of algorithms, a number of out-of-laboratory experiments can be conducted to provide the main guidelines in the synthesis of substances and/or to be used for comparative analysis of similar ones.

This report presents the authors' methodological scheme, in a form that avoids heavy mathematization, but presents complete results of the previous work. All

calculations are based on fundamental laws and published data (El-Banbi, 2018; Ahmed, 2019; Landau, 1984; Pawliszyn, 2012; Emsley, 1991; Critical Temperature and Pressure, 2006; Cengel, 2002), which were scientifically edited, with some of them already applied in practice.

## OBJECTIVE STATUS OF THE SCIENTIFIC TASK

The first theoretical derivation of a thermodynamic dependence related to the boiling temperature was presented in 1884 by the Norwegian mathematician and chemist Cato Maximilian Guldberg (Abrash, 1986; Bowden, 1954). There he presented the idea of the relationship of molecular mass with thermodynamic quantities (entropy, enthalpy, internal energy, etc.) and linked them with the possibility of empirical correction, namely measurement of the boiling temperature. By itself, this gives only a partial result – emphasis is placed on weight analysis, eliminating structural theory.

In 1955, Lydersen (Estimation of critical properties of organic compounds by the method of group

contributions, 1955) presented the possibility of calculating critical values by means of a group assessment contribution, i.e. how each functional chemical group burdens the values.

In the case of critical temperature, Lydersen's method is based on Guldberg's rule (roughly estimating, the normal boiling point  $T_b$ , when expressed in kelvins (i.e. as an absolute temperature), is approximately two-thirds of the critical temperature  $T_c$ ), which establishes a relationship between the normal boiling point and the critical boiling point.

The final theoretical results overlap with empirical ones only for individual nonpolar substances.

Lydersen's method is the prototype and predecessor of many new models such as Joback, Klincewicz (Klincewicz, 1984), Ambrose (Ambrose, 1978), Gani-Constantinou (Constantinou, 1984) and others.

In 1984, Joback (Joback, 1987) proposed a mathematical modification of Lydersen's formulas based on the idea that each  $G_i$  group differently affects the way it binds and, above all, the total number of unit groups in the molecule. For example, the number of chemical groups of one type and their topological location are important. Thus, the results for  $T_c$ ,  $P_c$  and  $V_c$  are very close to the empirical ones.

On the other hand, there are also semi-empirical methods – those in which individual calculated values can be replaced by measured ones. During the many years in the development of professional firefighting, a number of timeless experiments have been carried out. It is the integration of these data that is the basis of the presented methodology.

The title of the scientific research by the authors of the report is Applied Adaptation of Structural-Theoretical to Semi-Empirical Methods for Determining Critical Temperature, Pressure and Volume.

## METHODOLOGY

$T_c$ ,  $V_c$  and  $P_c$  are values subject to empirical confirmation. The study critical indicators are calculated from the molecular mass (Figure 1) by means of the Joback method with fragmentation of S. E. Stein (Stein, 1994). In turn, through several mathematical transformations, by means of basic laws in thermodynamics, the final values are obtained for: melting temperature, boiling temperature, free Gibbs energy, thermal capacity of the ideal gas, Heat of formation and the distribution coefficient  $\text{LogP}$ . A cross-check is also carried out precisely on the value of  $\text{LogP}$ .

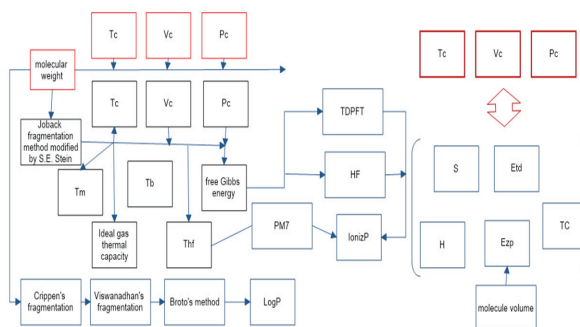


Figure 1. Methodological scheme for the analysis

From the molecular mass, through the so-called Ghose/Crippen's fragmentation (Souza, 2011), followed by Viswanadhan's fragmentation (Cabalo, 2014), and by applying Broto's method (Govers, 1992), a  $\text{LogP}$  value is obtained – directly independent of melting and boiling point (basic for the Joback method). The final results are expected to be similar. In case of a large deviation, both algorithms are meticulously checked.

Proceeding from the *OBJECTIVE STATUS OF THE SCIENTIFIC TASK* and applying minimization of the discrepancy between empirical and theoretical results, the value of  $T_{hf}$  (obtained theoretically) is taken and, knowing the molecular topology of the analyzed substance, semi-empirical quantum mechanical calculations of the type PM7 (Stewart, 2013) and the environment from MOPAC (MOPAC, 2022) are applied. This yields an independent value for the ionization potential (measurable quantity). The same transformation for the Gibbs free energy is repeated, but with the application of density-functional methods of TDDFT type (Medvedev, 2017) and wave-functional methods of HF type (Fischer, 1987) in a GAMESS US (GAMESS, 2022) medium.

At this point, individual values in the fundamental thermodynamic equations can be corrected and, by introducing the indicator "molecular volume", the values for entropy, enthalpy, heat capacity, absolute zero energy, and thermodynamic energy are obtained, as are the new values of the critical indicators.

The results are presented in a comparative illustration in Table 1. Their interpretation follows below.

Computations are performed in Octave GNU (GNU Octave, 2022) medium with standard and available GNU scripts (GNU General Public License, 2022).

## CONDUCTING THE EXPERIMENT

Table 1 contains data on the methodology for applied adaptation of structural-theoretical to semi-empirical methods for determining critical temperature, pressure and volume of selected chemical compounds.

**Table 1.** Values of empirical and calculated critical temperatures, pressures and volumes of selected chemical compounds

	Empirical value			Calculated value		
	T <sub>c</sub> , K	P <sub>c</sub> , MPa	V <sub>c</sub> , cm <sup>3</sup> /mol	T <sub>c</sub> , K	P <sub>c</sub> , MPa	V <sub>c</sub> , cm <sup>3</sup> /mol
Acetylene	309	6.1	95.6	341	6.2	109.5
Ethylene	383	5.1	104.7	373	5.3	129.5
Ethane	305	4.9	119.8	317	5.1	147.5
Propene	370	4.3	122.5	401	4.7	184.5
Propane	425	3.8	218.0	423	4.4	203.5
<i>n</i> -Butane	408	3.6	224.6	417	3.8	259.5
Isobutene	469	3.4	229.8	464	4.1	241.5
<i>n</i> -Pentane	460	3.4	261.5	451	3.5	309.5
Isopentane	434	3.2	379.3	439	3.4	315.5
Neopentane	507	3.0	398.5	498	3.5	304.5
<i>n</i> -Hexane	497	3.0	362.3	504	3.1	371.5

2-Methylpentane	504	3.1	351.2	493	3.1	365.5
3-Methylpentane	489	3.1	351.3	493	3.1	365.5
Neohexane (2,2-Dimethylbutane)	450	3.1	344.7	460	3.1	360.5
2,3-Dimethylbutane	540	2.7	338.2	529	3.1	359.5
<i>n</i> -Heptane	530	2.7	397.5	517	2.7	427.5
2-Methylhexane	535	2.8	402.7	528	2.8	421.5
3-Methylhexane	541	2.9	402.7	538	2.8	421.5
3-Ethylpentane	520	2.8	402.7	519	2.8	421.5
2,2-Dimethylpentane	519	2.7	396.8	513	2.8	416.5
2,4-Dimethylpentane	536	2.9	396.8	522	2.8	415.5
3,3-Dimethylpentane	531	2.9	396.8	530	2.8	416.5
Triptane	569	2.5	385.4	571	2.8	410.5
<i>n</i> -Octane	550	2.5	441.2	553	2.5	483.5
Diisobutyl	544	2.5	428.9	540	2.5	471.5
Isooctane	595	2.3	428.9	587	2.5	477.5
<i>n</i> -Nonane	617	2.1	497.2	613	2.3	539.5
<i>n</i> -Decane	670	3.2	515.3	663	2.9	595.5
Benzene	562	4.9	223.6	566	4.7	263.5
Toluene	592	4.1	301.8	593	4.1	319.5
Chlorotrifluoromethane	303	3.9	155.7	306	4.2	183.5
Trichlorofluoromethane	470	4.4	210.6	472	4.7	245.5
1,1,1,2-Tetrafluoroethane [Freon R-134a]	374	4.1	196.2	376	4.0	208.5
Ethanol	514	6.3	133.2	512	5.9	166.5

## CONCLUSIONS

- The determination of critical temperature by the proposed algorithm is sufficiently accurate ( $R^2=0.91\div 0.94$ ) for compounds with a molecular weight in the range of 80-460 g/mol. At lower values it does not differ significantly from the Joback method ( $R^2=0.88\div 0.90$ ), and for larger ones the accuracy is satisfactory ( $R^2=0.82\div 0.88$ );
- The theoretical calculation of critical volume is inaccurate ( $R^2=0.62\div 0.65$ ). For new substances, it can only be applied to conduct a comparative analysis of structurally similar ones.

## AUTHOR'S NOTES

The presented algorithm applies only to chemically pure substances. For those with technical frequency and material mixtures, it is applied in matrix form. Each cell represents a solution of a separate substance, which is also a matrix related to the purity of the compound and the total number of molecules in the entire system. For example, for a standard polyurethane by an industry-leading company, 162 thousand combinations were obtained. However, the final result is again close to the empirical measurement. Further research is required.

## REFERENCES

- Abrash, Henry I.; Gulberg, C. M. (1986). "Studies Concerning Affinity". Journal of Chemical Education. 63 (12): 1044–1047.
- Ahmed El-Banbi, Ahmed Alzahabi and Ahmed El-Maraghi, PVT Property Correlations, ISBN 978-0-12-812572-4, DOI: 10.1016/C2016-0-01806-5, 2018, Cairo.
- Ambrose, D. (1978). Correlation and Estimation of Vapour-Liquid Critical Properties. I. Critical Temperatures of Organic Compounds. National Physical Laboratory Reports Chemistry. Vol. 92. p. 1-35.
- Berche, B., Henkel, M., Kenna, R (2009) Critical phenomena: 150 years since Cagniard de la Tour. Journal of Physical Studies 13 (3), pp. 3001-1–3001-4.
- Bowden, S. T. (1954). "A Corrected Guldberg Rule". Nature. 174 (4430): 613–614. Bibcode:1954Natur.174..613B. doi:10.1038/174613b0. S2CID 4214592.
- Cengel, Yunus A.; Boles, Michael A. (2002). Thermodynamics: An Engineering Approach (Fourth ed.). McGraw-Hill. pp. 824. ISBN 978-0-07-238332-4.
- Constantinou, Leonidas; Gani, Rafiqul (1994). "New group contribution method for estimating properties of pure compounds". AIChE Journal. Wiley. 40 (10): 1697–1710. doi:10.1002/aic.690401011. ISSN 0001-1541.
- Critical Temperature and Pressure. Purdue University. <https://www.chem.purdue.edu/gchelp/liquids/critical.html> Retrieved 2006-12-19.
- Emsley, John (1991). The Elements (Second ed.). Oxford University Press. ISBN 978-0-19-855818-7.
- Estimation of critical properties of organic compounds by the method of group contributions, Madison University of Wisconsin, 1955.
- Froese Fischer, Charlotte (1987). "General Hartree-Fock program". Computer Physics Communications. 43 (3): 355–365. Bibcode:1987CoPhC..43..355F. doi:10.1016/0010-4655(87)90053-1.
- General Atomic and Molecular Electronic Structure System (GAMESS) is a general ab initio quantum chemistry package. - <https://www.msg.chem.iastate.edu/gamess>.
- GNU General Public License – <https://www.gnu.org/licenses/gpl-3.0.html>.
- GNU Octave – Scientific Programming Language – <https://octave.org>.



H.A.J. Govers, E.H.G. Evers (1992). Prediction of distribution properties by solubility parameters: Description of the method and application to methylbenzenes, *Chemosphere*, Volume 24, Issue 4, Pages 453-464, ISSN 0045-6535, [https://doi.org/10.1016/0045-6535\(92\)90420-V](https://doi.org/10.1016/0045-6535(92)90420-V).

Janusz Pawliszyn (2012) *Comprehensive Sampling and Sample Preparation*, ISBN: 9780123813749, Academic Press, London.

Jerry B. Cabalo. (2014) A comparison of QSAR based thermo and water solvation property prediction tools and experimental data for selected traditional chemical warfare agents and simulants, <https://apps.dtic.mil/sti/pdfs/ADA603243.pdf>.

Joback, K.G.; Reid, R.C. (1987). "Estimation of pure-component properties from group-contributions". *Chemical Engineering Communications*. Informa UK Limited. 57 (1–6): 233–243. doi:10.1080/00986448708960487. ISSN 0098-6445.

Klincewicz, K. M.; Reid, R. C. (1984). "Estimation of critical properties with group contribution methods". *AIChE Journal*. Wiley. 30 (1): 137–142. doi:10.1002/aic.690300119. ISSN 0001-1541.

Landau, Lifshitz (1984) *Theoretical Physics*, Vol. V: *Statistical Physics*, Ch. 83.

Medvedev, Michael G.; Bushmarinov, Ivan S.; Sun, Jianwei; Perdew, John P.; Lyssenko, Konstantin A. (2017-01-05). "Density functional theory is straying from the path toward the exact functional". *Science*. 355 (6320): 49–52. Bibcode:2017Sci...355...49M. doi:10.1126/science.aah5975. ISSN 0036-8075. PMID 28059761. S2CID 206652408.

MOPAC (Molecular Orbital PACKage), <http://openmopac.net>.

Souza, E. S., Zaramello, L., Kuhnen, C. A., Junkes, B., Yunes, R. A., & Heinzen, V. E. (2011). Estimating the octanol/water partition coefficient for aliphatic organic

compounds using semi-empirical electrotopological index. *International journal of molecular sciences*, 12(10), 7250–7264. <https://doi.org/10.3390/ijms12107250>.

Stanley, H. Eugene (1987). *Introduction to phase transitions and critical phenomena*. New York: Oxford University Press. ISBN 0-19-505316-8. OCLC 15696711.

Stein S. E., Brown R. L., "Estimation of Normal Boiling Points from Group Contributions", *J. Chem. Inf. Comput. Sci.* 34, 581–587 (1994).

Stewart J. J. (2013). Optimization of parameters for semiempirical methods VI: more modifications to the NDDO approximations and re-optimization of parameters. *Journal of molecular modeling*, 19(1), 1–32. <https://doi.org/10.1007/s00894-012-1667-x>.

Tarek Ahmed, *Reservoir Engineering Handbook*, Fifth Edition, ISBN978-0-12-813649-2 DOI: 10.1016/C2016-0-04718-6, 2019, Cairo.

## **BIOGRAPHY of the first author**

**Vasil Tsanov** was born in Sofia, Bulgaria, in 1982.

He is an associate professor of Occurrence and Cessation of Combustion and Chemistry at the Bulgarian Academy of the Ministry of Interior, Faculty of Fire Safety and Civil Protection.

His research interests are in the fields of molecular thermodynamics, mathematics, object-oriented programming and statistics.

DETELIN SPASOV<sup>1</sup>  
IVAN TODOROV<sup>2</sup>

<sup>1,2</sup>Academy of the Ministry of  
Interior,  
Faculty of Fire Safety and Civil  
Protection

<sup>1</sup>spasov@fplus-eu.com

<sup>2</sup>itodorov6@gmail.com

## EXPERIMENTAL DETERMINATION OF FIRE RESISTANCE OF SUSPENDED CEILINGS

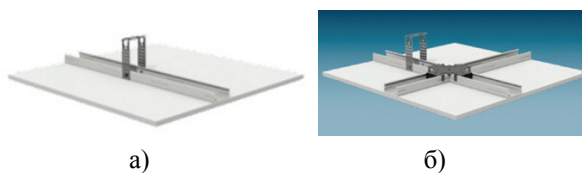
**Abstract:** This report presents and analyses data from fire resistance tests of suspended ceilings constructed using a load-bearing steel construction and a lining consisting of two layers of gypsum fibreboard. The obtained results for the variation of the temperature field are presented in graphical form. The fire resistance characteristics were determined for suspended ceilings.

**Key words:** fire resistance, suspended ceiling, methods for fire testing, gypsum fibreboard.

### INTRODUCTION

Suspended ceilings made of plasterboard are the most widely used ceiling structures in practice. Different types of plasterboards allow the ceilings to be installed in dry or wet rooms and in those with increased requirements for fire resistance. That is why the fire protection of steel structures is often achieved with the so-called smooth suspended ceilings. They are called 'smooth' because their underside is continuous and smooth.

Usually, manufacturers of plasterboard and gypsum fibreboards also offer developed systems for suspended ceilings. They are a system of steel supporting structure with metal hangers and plasterboards or gypsum fiberboards. The load-bearing structure can be on one level or on two levels (depending on the geometric dimensions of the room in which they are installed and the number and thickness of the boards from which the ceiling will be built (Spasov, 2022) (Figure 1).



**Figure 1.** Constructions of smooth ceilings with single and double load-bearing structures on a metal base

a) single metal structure; b) double metal structure

### PURPOSE

The purpose of this report is to present the results of preliminary fire resistance tests of suspended ceilings according to the methodology specified in BDS EN 13381-1.

### EXPOSITION

The tests are part of a large-scale research of the behavior of suspended ceilings made of a load-bearing steel structure and lining of several layers of gypsum fiberboard. The report will present the results obtained for a ceiling protected with two layers of gypsum fiberboard.

#### Test specimens

The test specimens include a horizontal structure that consists of the following, elements presented in Figure 2:

- **supporting steel (a)** structure- is a grid of supporting and mounting 60 mm x 27 mm CD-profiles by the company Knauf made of a galvanized steel sheet with a thickness of 0.6 mm, clamped together by means of connections for CD-profiles. The mounting profiles are 4-piece at a distance of 400 mm from each other, attached to the supporting structure of 2-piece profiles, at a distance of 800 mm. The supporting profiles are mounted to the supporting reference structure made of 3- piece steel 2T-shaped profiles IPE 160x82 mm, by means of 4 hangers type Nonius;
- **reference steel structure (b)**– consists of 5-piece steel beams with IPE 160 profile;
- **2 layers of gypsum fibreboards Vidiwall (c)**, with a thickness of 12.5 mm (total of 25 mm). They are mounted on mounting profiles of the supporting steel structure, by means of rapid screws, the distance between them being 150 mm;
- **200 mm thick air gap.** This is the distance between the gypsum fiberboards and the insulating reinforced concrete slab. The mounting and supporting steel profiles, as well as the reference steel structure, are located in it.
- **Insulating reinforced concrete slab with a thickness of 100 mm;**
- **The tested specimen** has the heated surface dimensions of 3000 mm x 4000 mm.

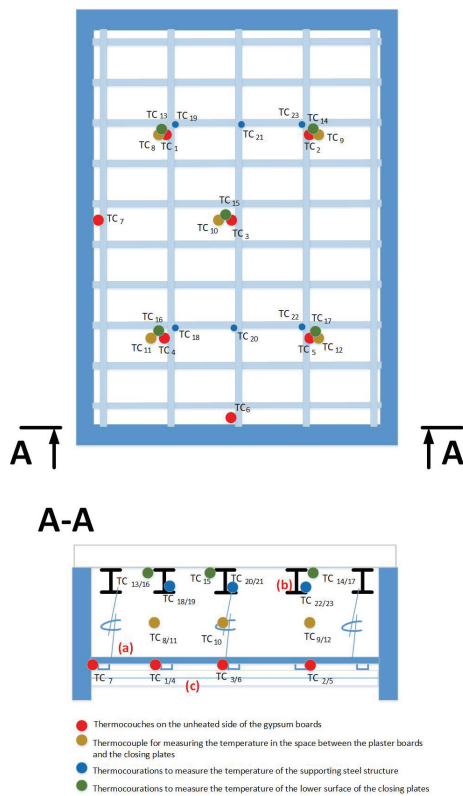


Figure 2. Temperature measurement scheme

**Temperature impact**

The temperature impact according to BDS EN 1363-1 is by dependence (1):

$$\theta_g = 20 + 345 \cdot \log_{10}(8t + 1), \quad (1)$$

where  $\theta_g$  is the temperature of the gases in °C and  $t$  is the time in minutes.

**Measured parameters**

Temperature in the furnace

The temperature in the furnace was measured by 8 thermocouples during the experiment. The average value of them for each moment of time is compared with its theoretical value obtained by dependence (1), and the permissible tolerance is determined.

Furnace pressure

A pressure of 12 Pa ± 2 Pa above the atmospheric pressure in the laboratory is maintained in the furnace space. It is measured at a distance of 100 mm below the lower surface of the test specimens.

Test specimen temperature

Figure 2 shows a scheme of the suspended ceiling, the location of the thermocouples, and their number.

**Test conditions and criteria**

The specimens were tested under one-sided fire impact from below the suspended ceiling. A standard temperature regime and test procedure described in BDS EN 1364-2 was used.

To assess the fire resistance of the ceiling, the limit temperature method described in detail in BDS EN 13381-1 was used.

Several limit temperatures at which the load bearing capacity of the ceiling is lost have been defined for different types of materials, namely:

- by measuring the temperature in the cavity of building elements containing steel beams or reinforced concrete slabs - 530 °C;
- by measuring the temperature of the surface of the steel beams - 510 °C.

**Test results**

**First test**

Figure 3 shows the obtained results for the change of the temperature field in the section of the ceiling during test 1.

It is observed that until the twelfth minute the temperature in the measured points of the cavity slowly increases and reaches 60 °C, which is due to the evaporation of moisture from layer 1 and partially from layer 2, as well as the thermal resistance of the protection of 2 layers of gypsum fibreboards (0,22÷0,24 m<sup>2</sup> °C/W). After that, the temperature rises slowly to 100 °C (at 31-33 min) according to a linear law, and in some places it plateaus and becomes parallel to the asymptote – axis X (see curve 5).

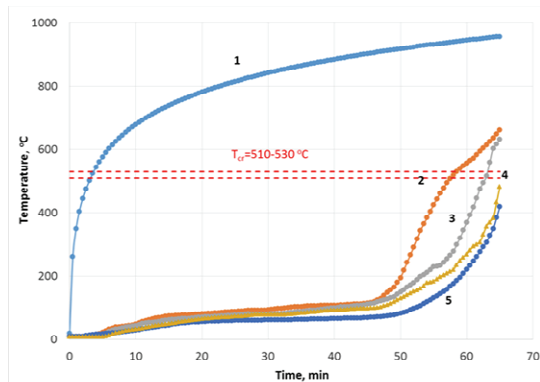


Figure 3. Change of the temperature field in the suspended ceiling during test 1

1 – standard temperature curve; 2 – temperature of the unheated surface of the gypsum fibreboard; 3 – air temperature in the gap; 4 – temperature of the reinforced concrete slab; 5 – temperature of the steel structure

Up to 46 min, the increase in temperature in the cavity continues to be linear at a rate of 1 °C/min-1.5 °C/min. After 46 min, and in the case of steel beams a little later at minute 50, a rapid and steep change in temperature curves 2-5 begins. This testifies to the complete destruction of one layer of gypsum fiberboard and the partial destruction of two layers. After that, within 10-12 min, the protection from gypsum plasterboards is completely destroyed and the temperature in the cavity quickly reaches critical values, leading to the loss of fire resistance.

A critical temperature of 510 °C is not reached in the steel beam in 65 min, and the critical temperature of 530 °C in the cavity is reached in 63.5 min. However, we must note that in one of the TDs, located on the surface of the steel beams, the value of 510 °C was reached. If we extrapolate the average temperature in the steel elements in Figure 3 we will find that the critical temperature of 510 °C will be reached after 2 min, i.e. at minute 67-68.

If there is a wooden structure in the ceiling- the prediction based on the test is related to reaching a critical temperature of 300 °C in the cavity, which is reached in 58 min.

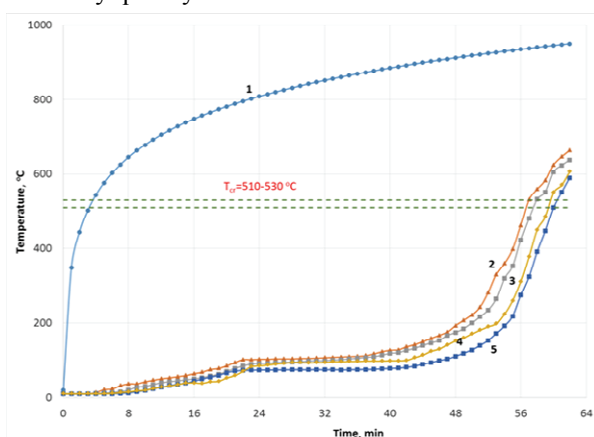
The following phenomena were observed during the test:

- 31<sup>st</sup> min - opening of the joint of the gypsum fiberboard of the first /lower/ layer;
- 38<sup>th</sup> min - destruction of the gypsum fiberboard of the first layer;
- 50<sup>th</sup> min - opening of the joint of the gypsum fiberboard of the second layer;
- 61<sup>st</sup> min - destruction of part of the gypsum fiberboard;
- 65<sup>th</sup> min - end of the test.

### Second test

Figure 4 shows the obtained results for the change of the temperature field in the section of the ceiling during test 2.

A significant similarity was observed in the variation of the temperature field during tests 1 and 2 up to 50 min, after which, as a result of faster destruction of the protection of the gypsum fibreboard, the temperature in the cavity quickly reaches critical values.



**Figure 4.** Change of the temperature field in the suspended ceiling during test 2

- 1 – standard temperature curve; 2 – temperature of the unheated surface of the gypsum fibreboard; 3 - air temperature in the gap; 4 – temperature of the reinforced concrete slab; 5 - temperature of the steel structure

The critical temperature of 510 °C is reached in the steel beam in 60 min, and the critical temperature of 530 °C in the cavity is reached in 58 min.

If there is a wooden structure in the ceiling- the prediction based on the test is related to reaching a critical temperature in the cavity of 300 °C, which is reached in 53.5 min.

The following phenomena were observed during the test:

- 38<sup>th</sup> min - opening of the joint of the gypsum fibreboard of the first/lower layer;
- 43<sup>rd</sup> min - destruction of the gypsum fiberboard of the first layer;
- 52<sup>nd</sup> min - opening of a joint between the fiberboards of the second layer;
- 56<sup>th</sup> min - destruction of part of the gypsum fibreboard;
- 62<sup>nd</sup> min - end of test.

### Fire resistance classification of the suspended ceiling

Fire resistance of the suspended ceiling is mainly classified according to the criterion of reaching a temperature increase of 180 °C above the initial temperature. If the initial temperature is assumed to be 20 °C, then the ceiling is classified as fire resistance class EI 45. This is based on the fact that the first thermocouple reaches 200 °C after 48 min (curve 2 in Figure 4). At the same time, the temperature of 510 °C measured on the steel beams was not reached in test 1, and was reached in test 2 at minute 60. For the benefit of security, we accept the results of test 2 as reliable. Therefore, the load-bearing steel profiles protected by the suspended ceiling are classified as R60.

The system- load-bearing steel beams under which the ceiling is installed can be classified as total fire resistance REI 45. The classification can be made on the basis of a test carried out according to BDS EN 1364-2, after changes have been made to the texts of the standard.

### INFERENCES

Based on the behavior of the suspended ceilings protected with two layers of gypsum fibreboard and the obtained results from fire resistance tests, the following conclusions can be drawn:

- (1) The destruction of gypsum fiberboards has a serious effect on the fire resistance performance. The destruction of the gypsum fibreboard protection occurs as a result of the temperature deformations and the opening of the joints between the individual pieces of gypsum fiberboard of each layer, and also as a result of the burning of the paper threads in the structure of the gypsum fiberboard and the sharp decrease in its strength. The error for the fire resistance between test 1 and test 2 is 12.5%.

- (2) The presence of moisture in the gypsum fibreboard leads to the retention of temperature of the unheated surface of the gypsum fiberboard up to 100 °C for 40 min;
- (3) The results obtained for the change in temperature and fire resistance in test 2 are weaker than those in test 1. The error in terms of temperature change after 50 min is significant, but it results in a 12.5% difference in fire resistance.
- (4) The fire resistance classification of ceilings, according to BDS EN 1364-2, leads to the conclusion that the load-bearing members located above it will retain the same classification in terms of load-bearing capacity, depending on the critical temperatures characteristic of the material from which they are made, based on the possibilities described in BDS EN 13381-1.

## CONCLUSION

It is necessary to make a proposal to add texts to item 13 of BDS EN 1364-2 related to the direct application of test results. The texts should allow the classification of load-bearing building members located above the ceiling to load-bearing capacity R. This is guaranteed on the basis of the fact that the load-bearing capacity of the building elements is lost at temperatures above 200 °C, which value is not reached until measuring the limit temperatures of 200 °C on the unheated side of the gypsum fiberboards.

## REFERENCES

- BDS EN 1363-1:2020 Fire resistance tests - Part 1: General requirements.
- BDS EN 1364-2:2018. Fire resistance tests for non-loadbearing elements - Part 2: Ceilings
- BDS EN 13381-1:2014. Test methods for determining the contribution to the fire resistance of structural members - Part 1: Horizontal protective membranes.
- Spasov, D. (2022), Fire-resistant horizontal fire protection partitions, ISBN 978-619-90328-9-3, Fplus.

## BIOGRAPHY of the first author

**Detelin Spasov** was born in Etropole, Bulgaria, in 1971.

He received a master's degree on the topic Automatics Control from the Technical University in Sofia and a Ph.D. degree on the topic Fire Technic and Emergency Safety



at the Academy of the Ministry of Interior, Sofia, Bulgaria, Faculty of Fire Safety and Civil Protection. He currently works at the Faculty of Fire Safety and Civil Protection, teaching the courses Production Automation and Control; Fire Automation; and Electrical and Explosive Protection of Electrical Devices and Installations.



NENAD KOMAZEC<sup>1</sup>  
KATARINA JANKOVIĆ<sup>2</sup>

<sup>1</sup> University of Defence, Military  
Academy

<sup>2</sup> General Staff of the Serbian Armed  
Forces, Technical Test Centre

<sup>1</sup>nenadkomazec@yahoo.com

<sup>2</sup>jankovickatarina95@gmail.com

## MANAGING DISASTER RISK BY DEVELOPING THE RESILIENCE OF LOCAL SELF-GOVERNMENT UNITS

**Abstract:** *The local level of administration represents the first line of responsibility and the degree of protection against disasters is directly dependent on its capacities. Although appropriate policies and an institutional framework are prerequisites for successful disaster risk management, building resilient communities has become one of the main tasks of local governments. Local authorities have an institutional and political responsibility to protect their citizens and are the first level of governance to undertake disaster risk reduction measures, prepare responses to future risks and respond to disasters. Weak governance, informal settlements on unsafe land, endangered ecosystems and rural environments are the main drivers of risk that need to be addressed in order to build more resilient local self-government units. The priority action in risk prevention is the assessment of the risks that exist in a certain area and the planning of measures for timely response in situations before the occurrence of natural disasters and other accidents.*

**Key words:** risk, disaster, resilience, local self-government unit

### INTRODUCTION

Local self-government units face serious consequences of natural disasters and they must become aware of the need for a comprehensive assessment of the risk to which they are exposed and accordingly develop the ability to adapt to changes and enable further progress. Problems such as poor infrastructure and public utility services, as well as illegally built settlements in risk zones, lead to extreme sensitivity of local self-government units and increase exposure to hazards.

The hazards that cause the most damage are hydro-meteorological and climatological hazards, i.e. droughts, earthquakes, blizzards, drifts and ice, stormy winds, and floods. These are some of the biggest challenges that local self-government units face. The risks of natural disasters are reflected in the potential loss of human lives, sources of income, property, services, etc.

The concept of a resilient system implies a set of available resources and capacities as a response to disturbances in the form of developing and implementing effective adaptation strategies that enable the system to cope with current and future events (UNISDR, 2012). Strengthening the resilience of local self-government units primarily refers to the establishment of effective disaster risk management. In a general sense, disaster risk management involves the implementation of activities before, during and after disasters in order to avoid or mitigate the consequences. The priority action in risk management is the assessment of the risks that exist in a certain area and the planning of measures for a timely response.

### RESILIENT SYSTEM CONCEPT AND DISASTER RISK MANAGEMENT

The role of local authorities is seen as crucial in dealing with disaster risk reduction and developing resilient communities (Maruna et al., 2018). Local authorities should be given the responsibility for managing disaster risk reduction by providing them with access to the necessary information and resources and authorizing them to implement actions.

#### The concept of a resilient system

After many natural disasters with catastrophic consequences, which affected settlements around the world, resilience emerged as a 'saviour' term that quickly replaced the term sustainability, which seemed to receive much of the blame for insufficient preparedness to resist disaster (Čolić et al., 2015). It has become a priority for local governments, non-governmental organizations, planners, managers, architects, designers, sociologists, ecologists, and engineers who are now pushing for a resilience agenda. Resilience, according to the definition by the United Nations, represents the ability of a system, community or society exposed to danger to resist, absorb, adapt and recover in a timely and efficient manner from the consequences of catastrophic events through the preservation and re-establishment of essential basic structures and functions (UNISDR, 2012).

However, there are also different interpretations. The text *The End of Sustainability* (Benson & Craig, 2017) states: "[...] resilience and sustainability are not the same. The pursuit of sustainability presupposes that: a)

we know what can be sustained and b) have the ability to maintain stationarity (i.e., keep the system functioning within an unchanging set of variability).” In contrast, resilience thinking acknowledges non-equilibrium and non-linear, continuous change, often as a result of crossing a ‘critical point’ and offers a means of assessing the dynamic relationships between systems. The goals of sustainability and resilience can be in serious conflict if they are not carefully agreed upon beforehand (Stupar and Simic, 2018). Local government disaster risk planning and management for both goals, resilience and a sustainable future, ensure that resilience goals overlap with and reinforce sustainability goals. Resilience, therefore, needs to be used for the purpose of strengthening sustainable development and should be seen as a supplement to sustainability, not as its replacement (Stupar and Simic, 2018).

### **Disaster risk management**

Reduction of the risk of disasters is directly conditioned by appropriate risk management. According to the Law on Disaster Risk Reduction and Emergency Management (Official Gazette of the RS 87/2018), risk management is a set of measures and activities that are implemented with the aim of implementing disaster risk reduction policies, as well as administrative, operational, and organizational skills and capacities for their implementation. Disaster risk management is based on mutual coordination and harmonized procedures and action plans of all institutions and entities and is carried out with intersectoral cooperation and partnership. Local self-government units have a primary role in disaster risk management and this role is supported by all competent state and provincial institutions.

Risk assessment is a prerequisite for decision-making, selection of priority projects and planning of risk reduction measures and recognition of high, medium, and low risk areas in risk management activities (UNISDR, 2012). The basis for risk assessment is the database of previous disasters, mapping of affected areas in GIS and assessment of the degree of vulnerability and exposure of people and property (UNISDR, 2012). Most often, the element that limits a precise risk assessment is the absence of or an incomplete database of previous disasters. This is supported by the fact that many hydrometeorological institutes, even in the most developed countries, do not have in their archives data on disasters older than 100 years, which therefore leaves room for certain inaccuracies in risk assessment (Ceres, 2013).

## **THE IMPORTANCE OF THE LOCAL LEVEL OF DISASTER RISK MANAGEMENT FOR INCREASING THE RESILIENCE OF LOCAL SELF-GOVERNMENT UNITS**

Effective disaster risk reduction requires a strong institutional foundation, which can be ensured through capacity building, good governance, promotion of appropriate policies and legislation, provision of information and effective coordination mechanisms. The local level of administration represents the first line of responsibility and the degree of protection against disasters is directly dependent on its capacities. Although appropriate policies and institutional framework are prerequisites for successful risk management, building resilient communities has become one of the main tasks of local government.

The local level of governance is of key importance for solving climate-generated challenges. Local authorities have an institutional and political responsibility to protect their citizens and are the first level of governance to undertake disaster risk reduction measures, prepare responses to future risks and respond to natural disasters (UNISDR, 2012).

Local self-government is responsible for providing services in the fields of health, education, traffic, and water supply, issuing building permits, managing public works, and controlling urban development, all of which provide an opportunity to achieve safer development and reduce the community's sensitivity to disasters. In order to fulfil their obligation to protect life, property, the economy and the environment, they need knowledge, instruments, capacities and resources.

Some of the important issues for increasing resilience, which concern local self-government, are the following:

- local self-government capacity (knowledge, experience, authorizations) for disaster risk reduction;
- the degree of cooperation between citizens, the private sector and local authorities in disaster risk reduction activities;
- the degree of inclusion of vulnerable groups of citizens (women, the elderly, the sick, children, etc.) in decision-making activities, the formation of management policies and the process of their implementation in order to reduce the risk of disasters;
- the degree of local self-government participation in disaster risk reduction and prevention planning at the national level (UNISDR, 2012).

### **Sendai framework at the local level**

In order to implement the Sendai Framework for disaster risk reduction at the local level, ten basic priority themes for developing resilience were developed (UNISDR, 2015). Each theme addresses one strategic area of intervention and identifies corresponding key activities (Table 1).

**Table 1.** Ten key themes of the operational framework of the Sendai Framework for disaster risk reduction (according to: UNISDR, 2015)

(1) Organize for disaster resilience	(6) Strengthen institutional capacities for resilience
(2) Strengthen the financial capacity for resilience	(7) Understand and strengthen social capacities for resilience
(3) Identify, understand and use scenarios to assess current and future risk	(8) Ensure effective response to disaster
(4) Continue resilient urban development and design	(9) Increase infrastructure resilience
(5) Protect natural cushioning zones for improving the protective functions of the ecosystem	(10) Speed up recovery and rebuilding

**Framework for Resilient Cities – 100 Resilient Cities Project**

The framework for resilient cities was developed by the ARUP organization, with the support of the Rockefeller Foundation (100 resilient cities, 2015). The Resilient Cities Framework is founded on four basic dimensions of urban resilience: (1) health and well-being; (2) economy and society; (3) infrastructure and environment and (4) leadership and strategies (Table 2).

**Table 2.** Framework for resilient cities (according to: 100 resilient cities, 2015)

Health and well-being	Meeting basic needs: providing key resources to meet basic physiological needs; Daily life support and employment: livelihood opportunities and support that enable the provision of basic needs; Provision of public health services: integrated health facilities and services and appropriate emergency services. It includes physical and mental health, health monitoring and developing awareness of healthy living.
Economy and society	Promoting cohesive and engaged communities: community engagement, social networks, and integration. They strengthen collective capacities for community improvement and require processes that encourage citizen engagement in planning and decision-making. Ensuring social stability, security and justice: law promotion, crime prevention, judiciary and emergency management; Supporting economic prosperity: supporting economic development in a broader sense. Important economic factors include: contingency planning, good management of city finances, ability to attract business investment, development of diverse economic profiles and expansion of networks.

Infrastructure and environment	Enhancement and protection of natural and created assets: environmental management, appropriate infrastructure, effective land use planning and enforcement of regulations; Ensuring continuity of services for critical situations: diversity of services, redundancy, active management and maintenance of ecosystems and infrastructure, and contingency planning. Ensuring reliable communications and mobility: a diverse and accessible multimodal transport network (roads, railways, road signs, signalling, etc.), public transport options and logistics (ports, airports, freight lines, etc.).
Leadership and strategies	Promoting leadership and effective management: applies to public administration, business sector and civil society. It involves trusted persons, multi-stakeholder consultations and evidence-based decision-making. Empowering a wide range of stakeholders: education for all, access to up-to-date data and provision of knowledge that enables people and organizations to take appropriate action; Supporting long-term and integrated planning: a holistic vision, supported by data. Strategies/plans must integrate different sectors, land use must include different departments, users and uses. Building regulations must ensure safety and reduce negative impacts.

**OECD Framework for Policies Development**

In June 2016, the Organization for Economic Cooperation and Development, OECD, adopted the preliminary version of the report on resilient systems (OECD, 2016). The report highlights the main approaches to the development of resilience policies that emphasize the importance of cooperation with other actors, such as the national level of government, neighbouring municipalities, non-governmental organizations, citizens and the private sector (Table 3) (Čolić et al., 2018).

**Table 3.** The development of resilience policies from the OECD report (according to: OECD, 2016 and Čolić et al., 2018).

(1) Adaptive – they are able to act based on past experience	Encouraging individuals and companies to develop innovation
(2) Strong – they have a well-formed system for accepting shocks	Support for new competitive industries to encourage industrial diversification Development of strategies for investment in reliable infrastructure
(3) Redundant – they have capacity saved for unexpected needs	Investing in infrastructure to create additional capacities for dealing with critical situations
(4) Flexible – they react to changed circumstances in plans	A long-term vision provides guidance in changing circumstances

(5) Surprising – they have ways to find resources to meet critical needs	Specialized administrative units for resilience strengthen public sector resources
(6) Inclusive – they bring together different perspectives	Involving stakeholders can improve the quality of policies and strengthen local communities Ensure access to opportunities for all citizens
(7) Integral – they work together beyond borders	Multi-level governance promotes better policy coordination Universities can become the centres of the alliance Alliances with other cities enable action at the level of the metropolitan area

## CONCLUSION

The improvement of disaster risk management at the local level poses a special problem in the case of developing countries, including the Republic of Serbia, where, in addition to the economic problems, insufficient development of professional capacities at the level of local government units, the absence of strategic urban development, low level of construction control and provision of services and the absence of citizen participation in decision-making are pronounced. The management of resilient systems is based on the position that solving the problem of disaster risk reduction should be directed towards strengthening the resilience of local self-government units by increasing the ability to resist, absorb, adapt, and recover from the consequences of natural or man-made disasters in a timely and efficient manner, while preserving and re-establishing of essential basic structures and functions.

The common content of the approaches mentioned in this paper (Sendai, the framework for resilient cities and the OECD framework for policies development) for the formation of management policies of resilient local self-government units consists of seven qualities that resilient local self-government units should contain: (1) the ability to learn from past events, (2) security of resources, (3) resistance to shocks, (4) ability to find alternative strategies, (5) flexibility in action, (6) inclusiveness and openness to different participants, and (7) integration of people, resources and institutions.

## REFERENCES

100 resilient cities (2015). *City Resilience Framework*. The Rockefeller Foundation & ARUP, available at: <https://www.rockefellerfoundation.org/report/city-resilience-framework/> [Accessed 1 July 2022]

Benson, M., Craig, R., (2017). *The End of Sustainability*, University Press of Kansas.

Cares, T. N. (2013). *Building Resilient Cities, from Risk Assessment to Redevelopment*. available at: <http://www.icleiusa.org/library/documents/building-climate-resilient-cities/> [Accessed 1 August 2022]

Čolić, R., Maruna, M., Milovanović Rodić, D., Lalović, K. (2015). *Integralni urbani projekti za upravljanje rizikom od poplava na primeru Obrenovca* katalog izložbe završnih radova generacije studenata 2013/14 Beograd: Univerzitet u Beogradu, Arhitektonski fakultet.

Maruna, M., Čolić, R., Milovanović Rodić, D. (2018). *Upravljanje razvojem rezilijentnih gradova: Primer Obrenovca*. [https://doi.org/10.18485/fb\\_ubur.2018.1.ch2](https://doi.org/10.18485/fb_ubur.2018.1.ch2). [Accessed 25 June 2022]

OECD (2016). *Resilient Cities: Policy Highlights of the OECD Report (Preliminary version)*. available at: <http://www.oecd.org/cfe/regional-policy/resilientcities-policy-highlights-preliminary.pdf> [Accessed 21 August 2022]

Official Gazette of the RS 87/2018, Law on Disaster Risk Reduction and Emergency Management.

Sendai Framework for Disaster Risk Reduction 2015–2030, [www.wcdrr.org](http://www.wcdrr.org). [Accessed 3 August 2022]

Stupar, A., Simic, I., (2018). *Rezilijentnost i(li) održivost? klimatska neizvesnost kao faktor u planiranju gradova*, [https://doi.org/10.18485/fb\\_ubur.2018.1.ch14](https://doi.org/10.18485/fb_ubur.2018.1.ch14). [Accessed 1<sup>st</sup> September 2022]

UNDP (2012). *United Nations Development Programme. Annual report 2011–2012: The sustainable future we want*

UNISDR (2012). *How To Make Cities More Resilient: A Handbook for Local Government Leaders*. Geneva.

## BIOGRAPHY of the first author

**Nenad Komazec** gained many years of experience in the field of protection and rescue through the development of various projects in the protection and rescue system of the Republic of Serbia. He is an active member of the commission A223 Safety and resilience of society at the Institute for Standardization of Serbia.



He was a member of program committees in the organization of several scientific and professional conferences and published papers in the field of protection and rescue, and disaster risk assessment. His areas of research include protection and rescue, risk management, civil defence, civil protection, organizational systems, and corporate security.

TIJANA IVANIŠEVIĆ<sup>1</sup>  
ALEKSANDAR TRIFUNOVIĆ<sup>2</sup>  
SVETLANA ČIČEVIĆ<sup>3</sup>  
ALEKSANDAR ŽUNJIĆ<sup>4</sup>  
VEDRAN VUKŠIĆ<sup>5</sup>  
SLOBODAN MITROVIĆ<sup>6</sup>

<sup>1</sup>Academy of Professional Studies  
Šumadija, Department in Kragujevac

<sup>2,3,6</sup>University of Belgrade,  
Faculty of Transport and Traffic  
Engineering

<sup>4</sup>University of Belgrade,  
Faculty of Mechanical Engineering

<sup>5</sup>P.E. "GSP Belgrade", Belgrade,  
Republic of Serbia

<sup>1</sup>tijana.ivanisevic@mail.com

<sup>2</sup>a.trifunovic@sf.bg.ac.rs

<sup>3</sup>s.cicevic@sf.bg.ac.rs

<sup>4</sup>azunjic@mas.bg.ac.rs

<sup>5</sup>vedran.vuksic@gsp.co.rs

<sup>6</sup>cobaja@sf.bg.ac.rs

## ROAD SAFETY IN ROADWORK ZONES

**Abstract:** *The number of zones where roadworks are carried out is continuously increasing, so the number of risky situations in which drivers can find themselves is also increasing. Roadwork zones represent high-risk conditions in traffic, both for road users and construction workers. This paper presents and analyses data on road crashes and their consequences in roadwork zones, including the analysis of four typical roadwork situations that could pose a risk for traffic participants.*

**Key words:** road construction zones, road maintenance, injury prevention, safety measures.

## INTRODUCTION

Traffic in Serbia, as well as in the whole world, records a constant increase, which results in an increase in the intensity of traffic, an increase in the degree of motorisation and an increase in travel time, which will initiate the construction, maintenance and rehabilitation of roads in the coming period. With such an expectation, it is not acceptable that there is a deterioration in safety and a reduction in traffic flow in the zones where roadworks are carried out.

Roadwork zones constitute traffic situations that are unexpected and unusual for most road users. The number of zones where roadworks are carried out is continuously increasing, so the number of high-risk situations, in terms of road safety, in which road users and construction workers can find themselves is also increasing (Cvetanović, 2008).

Road crashes that occur in roadwork zones are accompanied by property damage, fatalities and injured road users, as well as construction workers, so it is necessary that the zones where roadworks are carried out be equipped with appropriate traffic signs, devices and equipment for traffic regulation and provision of information for safer traffic.

## ROAD SAFETY INDICATORS IN ROADWORK ZONES

The data on road crashes in Serbia are collected by the Ministry of Internal Affairs (MIA), but monitored and analysed by the Road Safety Agency. In the integrated

database on the characteristics of road crashes, there are no data on the number of road crashes that occurred in roadwork zones. The reason why this type of road crashes is not registered can be found in the Road Crash Investigation Report itself. Namely, in the listed types of road crashes found in the Report, there is no 'checkbox' or any other option to record road crashes that occurred in roadwork zones.

While most high-income countries have teams of experts for road crashes, many countries, such as Serbia, rely on investigations carried out by the members of the traffic police. Improving the Report, and thus the database would enable the analysis of data related to identification as well as management of the number and consequences of road crashes that occurred in roadwork zones.

Bearing in mind the presented problem, this paper analyses and presents the indicators and characteristics of road crashes that occurred in roadwork zones in Virginia in the period from 1996 to 1999. Research has shown that the number of road crashes during roadworks increases by an average of 26% compared to the same section of the road in the same period of the previous year when the roadworks were not carried out. Also, the number of road crashes increases by 88% during long-term periods of roadwork compared to the period when they were not carried out (Garber & Zhao, 2002).

In the total number of road crashes that occurred in roadwork zones, road crashes with property damage



(61%), with casualties (38%) and with fatalities (1%) are the most common.

The most common types of road crashes in roadwork zones are collisions with a vehicle (52%), collisions with a stationary object on the road (13%), collisions with a stationary object off the road (12%), side collisions while moving (11%), collisions at an angle (4%) and other (8%).

The temporal distribution of road crashes that occurred in roadwork zones indicates that the largest number of road crashes (213) occurred in the period from 1 p.m. to 4 p.m., the highest percentage of fatalities (1.8%) was recorded in the period from 10 p.m. to 6 a.m., the highest percentage of injured road users (44.1%) was recorded between 10 a.m. and 1 p.m., while the highest percentage of property damage (68.9%) was recorded between 4 p.m. and 7 p.m.

## LEGISLATION FOR ROADWORK ZONES

Serbian legislation prescribes a framework for safe traffic in roadwork zones. The legal framework consists of the Rulebook on Traffic Signs, Signals and Road Markings, the Law on Public Roads and the Law on Road Safety, which define responsibilities and measures for safe traffic in roadwork zones (Technical recommendation for roadworks markings, 1992).

The Law on Public Roads defines the liability of companies that manage roads that may arise as a result of untimely roadworks, i.e. due to the performance of roadworks contrary to the prescribed technical conditions and method of performance (Law on Public Roads, 2007).

If the obstacles and the damage cannot be cleared immediately, the company that manages the road has to set up appropriate traffic signs and secure the location where the roadworks are carried out, which will enable the safe and smooth flow of traffic without time losses caused by traffic jams, as defined in the Law on Road Safety (Law on Road Safety, 2020).

According to the Law on Road Safety, the Technical Traffic Regulation project must be prepared for the installation of temporary traffic signs, except in cases of emergency roadworks that do not last longer than 24 hours, which would fully define the temporary traffic signs that would be installed in roadwork zones, so that road users are not misled and that there are no time losses, but also so as not to endanger the safe and smooth flow of traffic (Law on Road Safety, 2020).

During maintenance works or other construction works that do not last longer than 24 hours, certain measures should be taken immediately to eliminate disturbances and ensure the safe flow of traffic. Such measures do not require a Technical Traffic Regulation project (Law on Road Safety, 2020).

Temporary traffic signs that are used to mark roadworks are defined by the Rulebook on Traffic Signs, Signals and Road Markings, and must be implemented in the right places – around, in front of, and behind the place where the roadworks are carried out. Temporary traffic signs serve the purpose of timely warning drivers of the danger, providing the necessary information about the danger, directing the flow of traffic, and protecting road users and construction workers at the location of the roadwork, all to ensure safe traffic (Rulebook on Traffic Signs, Signals and Road Markings, 2021).

Traffic signs, markings and equipment in the roadwork zones are installed based on the traffic flow plan, which is approved by the authorized body. The traffic flow plan is designed by qualified and authorized designers, which is defined in the Law on Road Safety (Rulebook on Traffic Signs, Signals and Road Markings, 2021).

## EMERGENCE OF A DANGEROUS SITUATION IN ROADWORK ZONES

A large number of road crashes that occurred in roadwork zones were caused by inadequate safety of the roadwork zone, bad traffic routing, poorly conveyed messages and information to road users through temporary traffic signs in the work zone.



**Figure 1.** An example of poor regulation and direction of traffic in the roadwork zone

Although a legal framework has been defined in Serbia, ensuring the safe flow of traffic in roadwork zones, the reality on the roads indicates a significant problem with the correct installation of temporary traffic signs and, therefore, with the regulation and direction of traffic in the roadwork zones.

The procedure for issuing approval for the installation of temporary traffic signs in roadwork zones requires a Technical Traffic Regulation project, which is in accordance with the current Rulebook on Traffic Signs, Signals and Road Markings.

Namely, even if the Technical Traffic Regulation project has to be in accordance with the Rulebook on Traffic Signs, Signals and Road Markings, large differences were observed during the installation and,

therefore, during the project design by the designers. The designers sometimes use too many and sometimes too few traffic signs. Traffic signs that do not meet the criteria defined by the current Serbian legislation in terms of shape, dimensions, colour and method of placement are often placed in roadwork zones. Namely, traffic signs that are supposed to inform and warn road users that they are approaching a place where roadworks are carried out are often placed directly in front of the work site, on the dirt or road surface, simply leaning on another object or placed down on the road.

Bearing in mind all of the above, the problem of installing temporary traffic signs on the road can be solved by applying the Standard Solutions for traffic regulation.

The Standard Solutions for traffic regulation in the roadwork zones define the traffic signs as well as the distance at which they are placed in relation to the place where the roadworks are carried out.

**Example no. 1.** The plan for marking and securing the roadwork zone in a built-up area (50 km/h) when two-way traffic is not possible is presented. This is a typical solution for cases when the length of the roadwork zone is small, i.e. up to 50 meters, and traffic flows in one traffic lane. The first traffic signs are placed at a distance of 50 to 100 meters from the place where the roadworks are carried out, whereby the traffic participant is timely and adequately informed about the speed limit, about the roadworks, the narrowing of the roadway, the right of way, etc.

Bearing in mind that traffic signs I-19 *roadworks* and the II-30 *speed limit* are placed at a distance of 50 to 100 meters from the place where the roadworks are carried out, the stopping distance of vehicles at a speed of 50 km/h would be 76.01 m. In the street where the roadworks are carried out, traffic signs intended to warn and notify road users must be placed at a distance of at least 76.01 m. In the event that *roadworks* and *speed limit* traffic signs are placed at a distance greater than 76.01 m, drivers would be able to stop their vehicle by normal deceleration, that is, to adjust their driving to the traffic conditions. In this case, if a road crash were to occur on the part of the road managed by the roadwork company, the company would not be held accountable for the creation of a dangerous situation and the occurrence of the crash.

If the first traffic signs intended to warn and inform road users about a change in the traffic regime were placed at a distance of less than 76.01 m, drivers would be forced to adjust their driving to the traffic conditions by forced braking, thus becoming exposed to a dangerous situation by forced braking, because there is a possibility that the vehicle moving behind them will catch up with them, which can lead to a road crash. If, in this case, a road crash was to occur on the part of the road managed by the roadwork company, the company would be held accountable for the creation of a dangerous situation and the occurrence of the crash.

The stopping distance of the vehicle at a speed of 50 km/h, at a normal deceleration of 2 m/s<sup>2</sup> and with a reaction time of 2 s, would be

$$S = 13.89 \cdot 2 + 13.89^2 : 2 : 2$$

$$S = 27.78 + 48.23 = 76.01 \text{ m.}$$

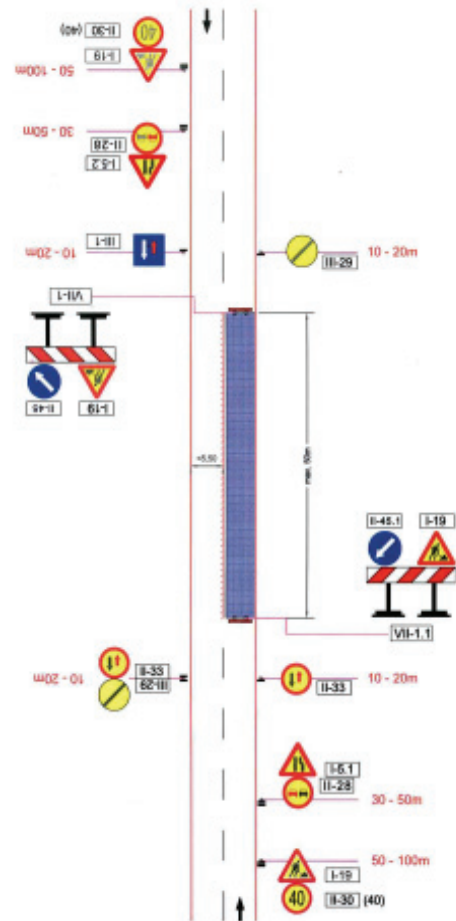


Figure 2. Example no. 1

**Example no. 2.** The plan for marking and securing the roadwork zone outside a built-up area, on a road with two traffic lanes, where the speed of 80-100 km/h is allowed (with alternating traffic management using traffic signs) is presented. This is an example of a typical solution for the case when the roadwork zone is longer than 50 meters. Traffic flows in one traffic lane, as regulated by traffic signs. The first traffic sign is placed at a distance of 400 meters from the place where the roadworks are carried out, whereby the road users are timely and adequately informed that they are approaching the roadwork zone, after which they receive information through traffic signs about speed limits, overtaking prohibitions, traffic lights, etc.

Bearing in mind the vehicle's stopping distance of 167.87 m at a speed of 80 km/h, as well as the fact that the traffic sign I-19 *roadworks* is located at a distance of 400 meters from the place where the roadworks are carried out, road users have time to adapt their driving to the conditions of safe traffic in the roadwork zone, and in the event of a road crash, the company that

manages the road would not be held responsible for the creation of a dangerous situation and the occurrence of the crash.

The stopping distance of the vehicle at a speed of 80 km/h, at a normal deceleration of 2 m/s<sup>2</sup> and with a reaction time of 2 s, would be

$$S = 22.22 \cdot 2 + 22.22^2 : 2 : 2$$

$$S = 44.44 + 123.43 = 167.87 \text{ m.}$$

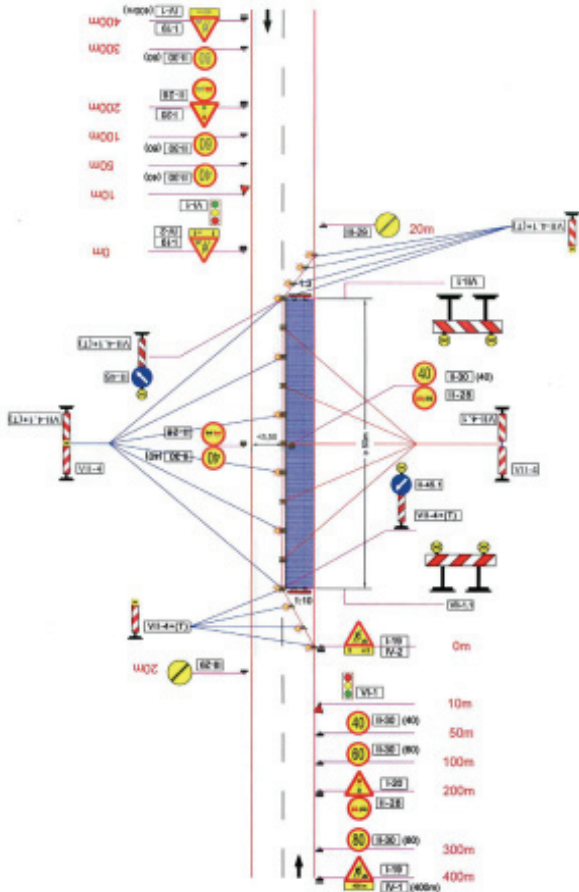


Figure 3. Example no. 2

**Example no. 3.** The plan for marking and securing the roadwork zone outside a built-up area, on a road with two traffic lanes, where the speed of 80-100 km/h is allowed (with alternating manual traffic management with flags) is presented. This is an example of a typical solution for the case when the roadwork zone is longer than 50 meters. The traffic flows in one traffic lane, and the construction workers who regulate the traffic in daytime conditions must be properly marked for better visibility on the road and be equipped with a radio connection, considering that the length of the roadwork zone is more than 50 meters. With the traffic sign I-19 *roadworks* placed at 400 meters, road users receive the information that they are switching from the normal traffic regime to the traffic regime in the roadwork zone.

Bearing in mind that the stopping distance of the vehicle at a speed of 100 km/h is 248.5 m and that the traffic sign I-19 *roadworks* is located at a distance of

400 meters from the place where the roadworks are carried out, road users have time to adjust their driving to the conditions of safe traffic in the roadwork zone, and in the event of a road crash, the company that manages the road would not be held accountable for the creation of a dangerous situation and the occurrence of the crash.

The stopping distance of the vehicle at a speed of 100 km/h, at a normal deceleration of 2 m/s<sup>2</sup> and with a reaction time of 2 s, would be

$$S = 27.78 \cdot 2 + 27.78^2 : 2 : 2$$

$$S = 55.56 + 192.93 = 248.5 \text{ m.}$$

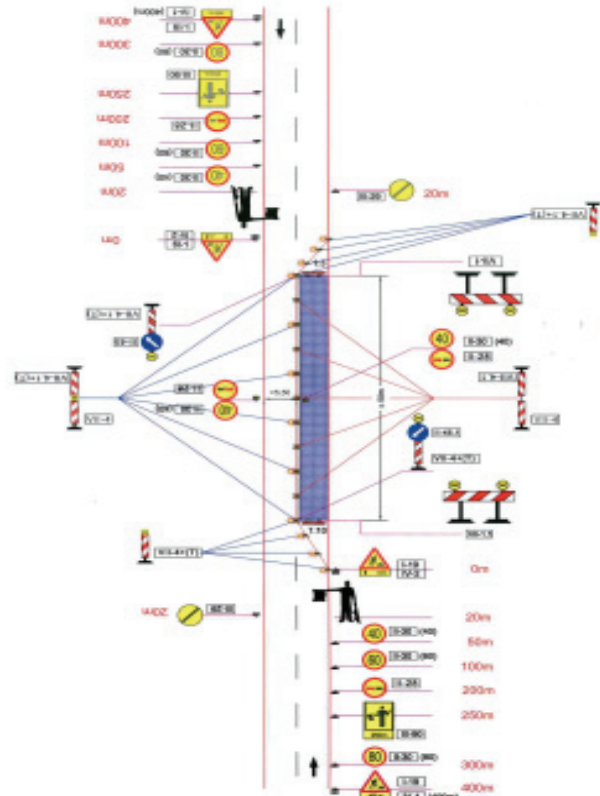


Figure 4. Example no. 3

**Example no. 4.** The plan for marking and securing the roadwork zone on a highway, with complete closure of the highway lanes and with traffic flowing on the opposite roadway, is presented. This is an example of a typical solution for the case when the roadwork zone is longer than 50 meters. At a distance of 800 meters, road users receive information through the traffic sign I-19 *roadworks* that they are approaching a roadwork zone, after which they receive information about the speed limit (60 km/h), overtaking prohibition, and information on the flow of traffic in the roadwork zone.

The stopping distance of the vehicle at a speed of 120 km/h would be 344.4 m, and bearing in mind that the traffic sign I-19 *roadworks* is located at a distance of 800 meters from the place where the roadworks are carried out, road users have time to adapt their driving to the conditions of safe traffic in the roadwork zone and in the event of a crash, the company that manages the road would not be held accountable for the creation



of a dangerous situation and the occurrence of the crash.

The stopping distance of the vehicle at a speed of 120 km/h, at a normal deceleration of  $2 \text{ m/s}^2$  and with a reaction time of 2 s, would be

$$S = 33.33 \cdot 2 + 33.33^2 : 2 : 2$$

$$S = 66.66 + 277.7 = 344.4 \text{ m.}$$

No marking or inadequate marking of the roadwork zones on the road constitutes an imperceptible, sudden, dangerous and unexpected obstacle for road users in the road lane, which may result in a dangerous situation as well as a road crash.

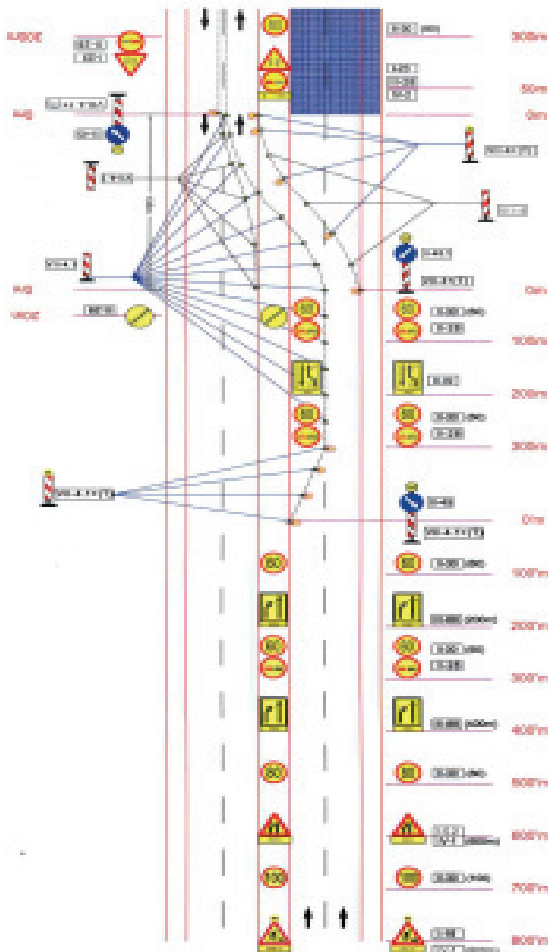


Figure 5. Example no. 4

The analysis of road crashes that occurred in the roadwork zones due to a suddenly arising dangerous situation, which drivers could not avoid in time, predict, or have a reason to expect, indicates that the circumstance that created the dangerous situation is the cause of the road crash. Namely, if a road crash occurred as a result of a dangerous situation in which drivers were placed due to poor traffic management and poorly transmitted messages and information through temporary traffic signs in the roadwork zone, any fault related to the creation of a dangerous situation and the occurrence of the crash lies on the company that manages the road and the responsible Technical Traffic Regulation project designer.

The Law on Public Roads defines the liability of a company that manages the road for damage caused to public road users due to the failure to perform specific works, i.e. due to the performance of those works contrary to the prescribed technical conditions and method of their performance.

Considering all of the above, the company that manages the road is obliged to ensure the safe and smooth flow of traffic for road users, whereas drivers, i.e. road users, have no reason to expect unmarked or inadequately marked roadwork zones. In the event of a road crash, any breach of the legal regulations by the company that manages the road will make the company and its responsible persons accountable for the creation of a dangerous situation and the occurrence of the crash.

## CONCLUSION

Roadwork zones constitute traffic situations that are unexpected but fairly common for most road users. A large number of road crashes that occurred in roadwork zones were caused by inadequate safety in the roadwork zone, bad traffic routing, and poorly conveyed messages and information to road users through temporary traffic signs in the work zone.

The legal regulations of the Republic of Serbia define the rights, obligations, duties, responsibilities and activities of companies that manage roads, traffic designers, and contractors. Namely, the company that manages the road is obliged to ensure the safe and smooth flow of traffic for road users, while drivers, that is, road users, have no reason to expect unmarked or inadequately marked roadwork zones.

Identifying the causes of road crashes is one of the most important steps in defining the problem, taking specific measures and identifying priorities, all with the aim of increasing road safety in roadwork zones.

## REFERENCES

- Cvetanović, A., & Banić, B. (2008). *Handbook for road workers*, Academic thought, Belgrade.
- Garber, N., & Zhao, M. (2002). *Crash Characteristics at Work Zones*, Virginia Transportation Research Council.
- Road crashes expertise, Institute of Faculty of Transport and Traffic Engineering in Belgrade.
- Rulebook on Traffic Signs, Signals and Road Markings, "Official Gazette of RS", number 85/17 and 14/2021.
- Technical recommendation for roadworks markings (1992), Federal Institute for Standardization.
- Law on Road Safety, "Official Gazette of RS", no. 41/2009, 53/2010, 101/2011, 32/2013, 55/2014, 96/2015, 9/2016, 24/2018, 41/2018, 41/2018, 87/2018, 23/2019 and 128/2020.
- Law on Public Roads, "Official Gazette of RS", number 101/2005, 123/2007.

## **ACKNOWLEDGEMENTS**

The authors acknowledge the constructive comments of two anonymous reviewers, which have significantly helped to improve this paper. This study was supported by The Ministry of Education, Science and Technological Development of Serbia (project 36027, 36022, and 36006).

## **BIOGRAPHY of the first author**

Tijana Ivanišević was born in Kragujevac, Serbia, in 1990.

She earned a degree in traffic engineering.

Her main research areas are traffic safety, new technologies, transport, etc.

She currently works as an assistant at the Academy of Professional Studies Šumadija, Department in Kragujevac.





ALEKSANDAR TRIFUNOVIĆ<sup>1</sup>  
SVETLANA ČIČEVIĆ<sup>2</sup>  
ALEKSANDAR ŽUNJIĆ<sup>3</sup>  
TIJANA IVANIŠEVIĆ<sup>4</sup>  
SLOBODAN MITROVIĆ<sup>5</sup>

<sup>1,2,5</sup> University of Belgrade,  
Faculty of Transport and Traffic  
Engineering

<sup>3</sup> University of Belgrade,  
Faculty of Mechanical Engineering

<sup>4</sup> Academy of Professional Studies  
Šumadija, Department in Kragujevac

<sup>1</sup>a.trifunovic@sf.bg.ac.rs

<sup>2</sup>s.cicevic@sf.bg.ac.rs

<sup>3</sup>azunjic@mas.bg.ac.rs

<sup>4</sup>tijana.ivanisevic@mail.com

<sup>5</sup>cobaja@sf.bg.ac.rs

## USE OF THE REAR-VIEW MIRROR IN THE VEHICLE FOR DISTANCE PERCEPTION: TRAFFIC SAFETY

**Abstract:** *It is generally recognized that sight is the most important sensory perception used to collect information while driving, comprising up to 90% of the total information collected. It is essential that the objects and stimuli that must be perceived to drive safely be the ones that drivers will observe and locate first. This is especially demanding when objects are perceived using mirrors in the vehicle. For the above reasons, an experimental study was carried out, which includes the evaluation of the distance with/without rear-view mirrors in the vehicle. The results show the difference in the estimation of distances when a rear-view mirror is and is not used. The test objects were of various colours, so the results also involve colour perception. The above results play an important role in improving the safety of all road users.*

**Key words:** rear-view mirror, traffic safety, perception, distance.

### INTRODUCTION

It is generally acknowledged that eyesight is the most important sensory perception used in gathering information during driving, comprising up to 90% of the total gathered information. It is very important that the objects and stimuli that must be perceived to maintain road traffic safety while driving be the ones that are perceived and located by the driver first (CIE Publication, 137-2000). As visibility is the ability of distinguishing particular situations conditioned by light, its determinants during driving could be expressed in the form of visibility distance and visibility rate, which are dependent on road and weather conditions. The visibility distance is the minimum distance at which an object cannot be clearly distinguished from its surroundings when viewed in 3D space. The visibility rate is the ability to distinguish an object's characteristics: its colour, shape, etc. (Škerović et al., 2011).

In the study conducted by Gudžulić and Baroš (2008), it is observed that the change in body position affects distance perception at distances longer than 1m, i.e. 3m and 5m. The basis of visual system function is the projection of light rays that carry information about the object on the retina and projects on it a two-dimensional picture. As a consequence of the retinal projection of a picture, the third dimension, or depth, is lost. The distance is reconstructed further during the perception process with the help of the so-called depth cues. According to Palmer (1999), distance cues can be categorized in different ways. The most commonly used terms are binocular/monocular cues and relative/absolute distance cues. Binocular cues are available from both eyes, whereas monocular cues are available from only one eye. Relative/absolute distance

cues provide information about relative distance and absolute distance, respectively. It is also very important to note that some cues provide numerical information about distance (quantitative), while others only indicate whether objects are closer or farther away (qualitative). Some of them provide absolute information, whereas others provide only relative information. Gogel (1978) distinguished between two kinds of distance cues. Egocentric cues determine the perceived distance of a point or object from the observer, providing perceived egocentric distances. For researchers, perceived egocentric distance (or simply perceived distance, absolute distance) is a representation of the distance between oneself and an object (Woods et al., 2009). Exocentric cues indicate the perceived, or the distance between points or objects, providing perceived exocentric distances (Gogel, 1978). The type of information a cue can provide is also worth mentioning. According to Sweet and Kaiser (2011), some cues provide only ordinal information (e.g. "Object B is behind Object A"), others provide relative information (e.g. "Object B is twice as far away as Object A"), while still others may provide absolute information (e.g. "Object B is 2 units away and Object A is 1"). Visual information can provide a numerical value of distance (quantitative information) or just the relation of distances of two objects – near-far (qualitative information) (Palmer, 1999). Man's visual system makes mistakes in distance assessment in some cases even though there are depth cues present (so-called optical illusions) (Ross and Plug, 2002). In the earlier studies it has been concluded that the position of the body, head and eyes affects spatial perception (Kaufman and Rok, 1962), so that the perception while driving with and without the rear-view mirror may result in different distance assessments, which can be a relevant result for traffic safety.

In the study conducted by Roy in France in 2011 it was determined that 20% of the drivers drive with the eyesight weaker than 0.8 (80%), and that in France 8 million drivers in total with the eyesight weaker than 50% participate in traffic. At the same time, 29% of the drivers do not use any optical aid although it is recommended that they do. The research conducted in the UK determined that a third of the drivers do not check their vision regularly. According to the World Health Organization, 285 million people have some type of visual impairment (including 19 million children), whereby 80% of visual impairment is preventable, and, crucially, 90% of the visually impaired live in developing countries (WHO, 2014).

In a study conducted in the Netherlands in 2010, 1.5% of the drivers older than 75 drove with visual acuity below the statutory minimum (50%). In Italy, a study was conducted by the University of Milan in 2009, by which it was established that as many as 32.17% of the tested drivers did not meet any of the criteria for obtaining or renewing a driver's license, while 16.67% of them had visual acuity of less than 50% (Maffioletti, 2009).

A study conducted in Croatia (Petriček, 2011) showed that in 2011, 27% of the drivers did not have optimal vision (100% correct vision), which is nearly a third more than in 2010 (20%). The average in European countries is 23%. In Croatia, among drivers over 40 years, 11% of them drive with visual acuity below the statutory minimum (80% correct vision). The same survey showed that 46% of the drivers who wear glasses have not checked them in the last 2 years, and 2% never have. Thirteen percent of the drivers who do not wear glasses have never undergone an eye exam, while 58% of the drivers surveyed said that they had problems with driving at night (56% of men and 63% of women).

Interestingly, more men do not want to acknowledge the problem with driving at night, though vision control shows extremely poor eyesight (20%). Data from the United Kingdom for 2012 show that over 2,000 traffic accidents were due to inadequate vision, resulting in damage of 33 million pounds and 3,000 injured persons (IRTAD, 2013). In contrast, the study conducted by Charman in 1997 did not find any association between lower colour vision and traffic accidents (Charman, 1997). In a number of countries (USA, Canada, United Kingdom), when a person takes the driving test, the examiner checks the visual acuity of the candidates simply by asking them to read a license plate at a distance of 20 meters.

Blind spots in passenger vehicles are very often considered as a problem in the literature (Chun et al., 2013; Vincent, 2013; Pitchipoo, 2014). A common way to reduce blind spots is to use rear-view mirrors in the vehicle. The study conducted by O'Brien in 2004 shows the costs and benefits of proper use of rear-view mirrors in the vehicle and it justified the introduction of additional rear-view mirrors in large freight vehicles (O'Brien 2004). The above-mentioned problem is much more pronounced in trucks, especially when it

comes to freight vehicles with a trailer. The new directive on rear-view mirrors in vehicles 2003/97/EC (European Commission, 2004) aims to increase the field of view around the trucks. New commercial vehicles in Europe are equipped with rear-view mirrors that have to meet the new regulations. According to previous European directive on rear-view mirrors in motor vehicles (71/127/EEC (European Commission, 1971)) trucks weighing more than 8 tonnes were equipped with at least three rear-view mirrors on the passenger side and one on the driver's side. The new directive 2003/97/EC requires an additional rear-view mirror for the driver's side and one at the front of the vehicle. It is also allowed to use a surveillance system with a camera instead of a frontal rear-view mirror. A study conducted in 2011 states that countries have focused transportation policy towards the implementation of this directive. The cited study does not mention that the directive has been implemented in Serbia as well (McGrath, 2011).

Within its vehicle safety check activities, the DEKRA company performs studies analysing the visual field in passenger vehicles (DEKRA, 2022). There are two categories of research results, those obtained using rear-view mirror settings in the vehicle according to the old directive (71/127/EC) and those obtained from the use of rear-view mirrors settings according to the new directive (2003/97/EC). The results showed that the wide-angle rear-view mirrors in the vehicle, which are set by the old legislation, have medium values that are very close to the target (desired) value. Using wide-angle rear-view mirrors in the vehicle, set according to the new regulations, did not produce the expected results. Consequently, this means that in many cases advantages of the new rear-view mirrors in the vehicle cannot be fully exploited, because the rear-view mirrors are more helpful in noticing details at the side of the truck and/or trailer while other angles are neglected.

Blind spots in passenger cars are also of great importance for road safety. They are mainly caused by the presence of A, B and C pillars. The problem is limited to a two-dimensional plane and is thus much smaller than in commercial vehicles: trucks have a third dimension as far as blind spots are concerned. This problem is a consequence of the height difference between the truck driver's eyes and the eyes of other road users (e.g. pedestrians or drivers of passenger cars). The eyes of truck drivers are approximately at a height of 2.5 m for most European trucks (weighing more than 8 tonnes), while the eyes of pedestrians are at a height of 1.6 m (for an average person). In addition to the height of the driver's eye, there are three important influential factors that determine the size of the blind spot. One is the height of the lower edge of the windscreen and the second is the side windows' shape. The third is the horizontal distance between the driver and the window. These three factors influence the way that blind spots outside the truck will be visible (Niewoehner, 2009).

The distribution of visual attention while driving is a key element to prevent traffic accidents (Ciceri and Ruscio, 2014), and the less blind spots the driver has

around his vehicles, the safer the driving will be. A study by Kidd and Brethwaite (2014) shows that smaller vehicles have a lower area of blind spots, while larger vehicles (SUVs) have a larger area of blind spots, particularly at the rear of the vehicle. Proper use of rear-view mirrors in the vehicle reduces the number and area of blind spots.

In addition to practical experiments for analysing the use of rear-view mirrors in the vehicle, there are a variety of computer simulations. Such simulations are applied to a wide range of vehicles, which are currently used by car manufacturers. In addition to the tests that are conducted prescribed by applicable international standards, specific procedures are aimed to optimize and test visibility using rear-view mirrors in the vehicle (Carfagna and Landi, 2002).

Contribution of the rear-view mirrors in the vehicle is evident, as they are technical resources for the improvement of traffic safety providing considerable help to drivers of motor vehicles for safe participation in traffic. The studies mentioned in this paper mostly focus on the use of rear-view mirrors in the vehicle in order to reduce blind spots (blind zones) and on their importance for certain categories of motor vehicles. The aim of this study is to investigate how rear-view mirrors affect distance estimation by drivers.

## METHODOLOGY

The experiment was performed in a closed laboratory, which is illuminated by natural light. A rear-view mirror and four boxes were placed in the laboratory, identical in shape and size, only in different colours (Figure 1).



**Figure 1.** Environment and facilities used in the experiment

### Description of boxes used in the experiment

Four identically shaped boxes, 25 cm high, 36 cm long, and 26 cm wide were used in the experiment. The boxes were wrapped in different colours:

- Box 1: A coated yellow reflective foil;
- Box 2: A coated blue reflective foil;
- Box 3: A coated red paper wrap, without reflection;
- Box 4: A coated green paper wrap, without reflection.

The choice of colour boxes was made on the basis of colours predominantly used in traffic signs. The light signals on traffic lights include red and green. All traffic warning signs and some signs of explicit orders are also lined with red (e.g. the no pedestrians sign (II-17) denoting a road or road section where access is prohibited for pedestrians).

Some mandatory and information traffic signs are blue. Pedestrian crossing traffic sign, for example, consist mainly of a blue colour, as do some mandatory traffic signs (the pedestrian path sign (II-41), which indicates a path that pedestrians must use, and other road users are not permitted to use).

Yellow, as the brightest, most visible and most vocal colour, which is used on all the signs related to roadworks, on certain notification signs, on traffic lights for cars and cyclists, as well as on individual elements of horizontal signalization, was the colour on the fourth coloured box. The men at work sign (I-19) denoting the place where roadworks are performed, has a base of yellow (Rules on traffic signs, 2021).

### The position of the rear-view mirror

In the experiment, the rear-view mirror was placed at a height of 1.2 m from floor level. The first box was set 4.5 m from the place where the test subject was sitting, the second at 5.5 m, and the third and fourth 6 m and 7 m from the test subject, respectively. The task was to first adjust the rear-view mirror so that the subject can see all the boxes behind it and then to estimate the distance from the box (Figure 2). The second part of the task involved the subject standing up from where he sat, looking at the box in front of him and estimating the distance without the rear-view mirror. After that the test subject completed a demographic survey and answered questions related to the driving test and the frequency of driving motor vehicles (Trifunović et al., 2022; Trifunović et al., 2017).



**Figure 2.** View of the boxes with the aid of the rear-view mirror during the experiment

## Data analysis

The survey was placed on the Google Drive platform to facilitate data collection and processing. Normality of distribution was tested by inspection of the histogram and the Kolmogorov-Smirnov test. Since the distribution of all interval variables significantly deviated from the normal distribution, we used the nonparametric method. To assess the significance of differences we used the Kruskal-Wallis test, the Mann-Whitney U-test, and the Wilcoxon matched-pairs test. The following null hypothesis was set ( $H_0$ ): There is no statistically significant difference between the groups; and the following alternative hypothesis ( $H_a$ ): There is a statistically significant difference between the groups. The threshold of statistical significance ( $\alpha$ ) was set at 5%. Therefore, if  $p \leq 0.05$ ,  $H_0$  is rejected and  $H_a$  accepted, and if  $p > 0.05$ ,  $H_0$  is accepted (Pešić et al., 2019).

## RESULTS

### Descriptive statistics

The experiment involved 16 participants, aged from 19 to 22. A larger number of the test subjects were males (9) while 7 test subjects were females. Of all the test subjects, 68.75% had a category B driver's licence, 12.5% had a category B and E licence, 6.25% had a category B and A licence, while the remaining subjects (12.5%) were still in driving school. Of the subjects with a licence, 6.25% had it for less than a year, 75% between one and three years, and 6.25% between three and five years; additionally, 37.5% drove every day, 12.5% between three and five times a week, 25% fewer than three times a week, 6.25% fewer than three times a month, and 6.25% fewer than three times a year. Since the topic of study is distance perception using rear-view mirrors, test subjects provided data on the use of spectacles or contact lenses. Specifically, 62.5% of the respondents did not use eyeglasses or contact lenses, while 37.5% did.

### Distance perception

The first analysis of the data relates to the influence of colour on the estimation of distances with and without a rear-view mirror. Based on the results of descriptive statistics (Figure 3), it can be concluded that the average distance for the colours yellow and blue is shorter when the test subjects estimate distance using rear-view mirrors, while the standard deviation is higher for any colour when the assessment is performed with the aid of rear-view mirrors (except for blue for equidistance). It can also be concluded that yellow is perceived as the closest when using a mirror, followed by blue and red, and green as the furthest, whereas green is perceived as the closest without a mirror, followed by blue and yellow, and red as the furthest.

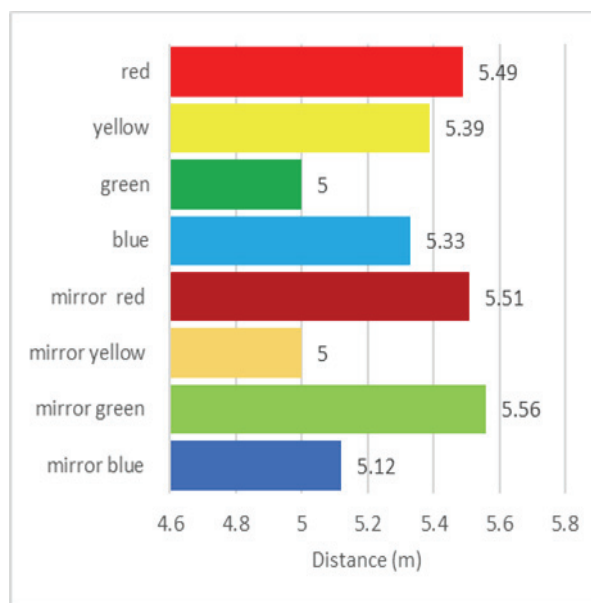
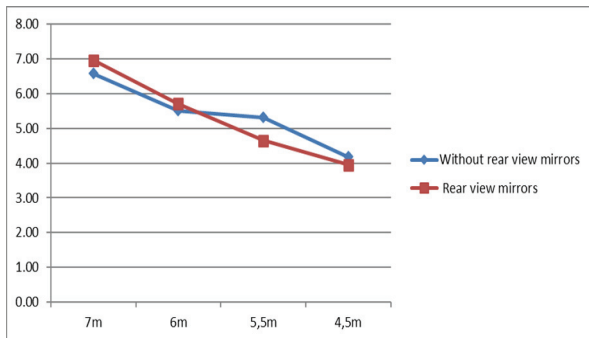


Figure 3. Results of distance estimations based on the colours

Based on the Pearson correlation, we found a statistically significant relationship and a highly significant positive correlation between the colours of the boxes in the estimation of the distance with and without mirrors, i.e. based on the estimation of the distance of one colour, we can predict the estimation of the distance of any of the other colours (with or without mirrors). Based on the results of normality distribution, we used nonparametric tests, Mann Whitney and Kruskal Wallis, to analyse the results, which showed statistically significant differences. In addition to this statistical analysis, based on the recommendations of the textbook *SPSS survival manual* (Pallant, 2011), the Wilcoxon matched-pairs test showed a statistically significant difference in the estimated distances with and without rear-view mirrors for colour blue ( $z = -3.025$ ;  $p = 0.003$ ) and red ( $z = 2.684$ ,  $p = 0.009$ ). Based on the results of the sum of the ranks for the colour blue with and without rear-view mirrors, it can be concluded that the estimated distance is shorter with the rear-view mirror. Regarding the red-coloured box, the sum of ranks with a rear-view mirror is greater than the sum of ranks without a rear-view mirror, so it can be concluded that the distance at which the red box is estimated is greater if a rear-view mirror is used.

Based on Table 1 and Figure 4 it can be concluded that for smaller values of the distance (4.5 m and 5.5 m) the distance using a rear-view mirror is underestimated, whereas for higher values (6 m and 7 m) the distance is overestimated. If this trend of distance estimation using rear-view mirrors is also valid for distances greater than 7 m, a big problem arises, because the drivers think they have a greater distance available, so they behave accordingly (e.g., assessment of vehicle distance using rear-view mirrors, when the driver decides to brake, thinking that the car behind is further than it actually is).





**Figure 4.** The average value of the distance estimation with and without a rear-view mirror for various distances

**Table 1.** Descriptive statistics of the results of estimation of distances for different estimated distances

		Rvm 7m	Rvm 6m	Rvm 5.5m	Rvm 4.5m	7m	6m	5.5 m	4.5 m
N	Valid	82	82	82	82	82	82	82	82
	Miss.	0	0	0	0	0	0	0	0
Mean		6.96	5.71	4.65	3.95	6.5	5.5	5.32	4.18
Std. Error of Mean		.2092	.1686	.1360	.1354	.16	.14	.119	.112
Median		6.150	5.500	4.500	4.000	6.0	5.1	4.50	4.00
Mode		7.00	5.00	4.00	3.00	7.0	5.0	4.50	4.00
Std. Deviation		1.99	1.71	1.13	1.30	1.3	1.4	1.03	0.99
Variance		3.591	2.332	1.518	1.504	2.1	1.6	1.18	1.03
Minimum		4.00	2.00	3.00	2.00	4.0	3.0	4.00	2.00
Maximum		14.00	11.00	8.00	8.00	10.	9.0	8.00	7.00
Sum		531.9	459.3	371.2	315.5	500	449	379	338
P e r c e n t	25	5.00	4.50	3.675	3.00	5.0	4.5	4.00	3.50
	50	6.150	5.500	4.500	4.000	6.0	5.1	4.50	4.00
	75	7.00	6.50	5.050	4.500	7.0	6.5	5.50	5.00

\* Rvm = Rear-view mirror

## CONCLUSION

The most significant findings of the experiment analysed and explained in this paper are the following:

- Using rear-view mirrors, yellow can be perceived as the closest, followed by blue and red, and green is perceived as the farthest colour;
- Green is perceived as the closest without rear-view mirrors, followed by blue, and yellow, and red is perceived as the farthest;
- Standard deviation has a greater value when estimating distances with a rear-view mirror for all colours except for blue (for equidistance);
- There is a statistically significant difference in the assessment of distance with and without rear-view mirrors for blue and red;

- For blue, the estimated distance is smaller when using a rear-view mirror compared to the assessment without a rear-view mirror, while the reverse is true for red (distance from the red box is estimated as larger when using a rear-view mirror);
- Warm colours (yellow and red) are seen as being further if using a rear-view mirror, as opposed to cold colours (blue and green), which are perceived as closer if using a rear-view mirror to estimate distances;
- When the value of the distance is lower (4.5 m and 5.5 m), the distance is underestimated when using rear-view mirrors, and at the same time overestimated for higher values (when an object is located at distances of 6 m and 7 m).

These results are of great importance for road safety, especially the overestimation of distance for more than 6 m. Also, it has been shown that different colours are perceived differently when using rear-view mirrors in terms of distance estimation, which can be used primarily for the analysis of accidents that occurred when the vehicle was backing up. Future studies should confirm the results and strengthen the interpretation of the research presented in this paper. In addition, future research should be directed toward increasing distances from the rear-view mirror, introducing new facilities and different colours, sizes and shapes of the stimulus, and conducting experiments under various visibility conditions (morning, noon, evening, night, foggy conditions). Future research could also include rear-view mirror variations (different sizes and shapes of rear-view mirrors, as well as different types and forms of glass).

## REFERENCES

Charman, W. N. (1997). Vision and driving – a literature review and commentary. *Ophthalmic and Physiological Optics*, 17(5), 371-391.

Chun, J., Lee, I., Park, G., Seo, J., Choi, S., & Han, S. H. (2013). Efficacy of haptic blind spot warnings applied through a steering wheel or a seatbelt. *Transportation research part F: traffic psychology and behaviour*, 21, 231-241.

Ciceri, M. R., & Ruscio, D. (2014). Does driving experience in video games count? Hazard anticipation and visual exploration of male gamers as function of driving experience. *Transportation research part F: traffic psychology and behaviour*, 22, 76-85.

DEKRA. (2022). Safety Check. <https://www.dekraauto.co.za/safety-check>

Passenger Transportation, Accident Prevention Strategies on Europe’s Roads.

European Commission – Enterprise and Industry. Directive 2003/97/EC. 29.01.2004.

European Commission – Enterprise and Industry. Directive 71/127/EWG. 22.03.1971.



- Gudzulić, V., Baroš, M. (2008). Upside-down world – importance of vestibular information in distance perception, *Psychology*, 22, 81-95.
- Kaufman, L., & Rok, I. (1962). The Moon Illusion. In Held R. Richards (Ed.), *Perception: Mechanisms and Models*. San Francisco: W. H. Freeman and Company, pp. 260-268.
- Kidd, D. G., & Brethwaite, A. (2014). Visibility of children behind 2010–2013 model year passenger vehicles using glances, mirrors, and backup cameras and parking sensors. *Accident Analysis & Prevention*, 66, 158-167.
- Law on Road Traffic Safety. (2020). *Official Gazette of the RS*, No. 41/2009, 128/2020.
- Maffioletti, S., Pocaterra, R., & Tavazzi, S. (2009). The importance of precise sight correction for safe driving. *Undergraduate Degree Course in Optics and Optometry*.
- McGrath, M. (2011). Published Project Report PPR588, A study of the implementation of Directive 2007/38/EC on the retrofitting of blind spot mirrors to HGVs. *Transport Research Laboratory*.
- Niewoehner, W. (2009). How to Use Mirrors. In *Proceedings of the 21st (Esv) International Technical Conference on the Enhanced Safety of Vehicles*, Held June 2009, Stuttgart, Germany.
- O'Brien. (2004). Cost benefit analysis on blind spot mirrors – final report. *Jacobs consultancy*.
- Palmer, S. E. (1999). *Vision science: Photons to phenomenology*. MIT press.
- Pešić, D., Trifunović, A., Ivković, I., Čičević, S., & Žunjić, A. (2019). Evaluation of the effects of daytime running lights for passenger cars. *Transportation research part F: traffic psychology and behaviour*, 66, 252-261.
- Petriček, I. (2012). How our drivers see – the results of vision tests among our drivers. *Clinic for eye diseases KBC Zagreb, Zagreb*.
- Pitchipoo, P., Vincent, D. S., Rajini, N., & Rajakarunakaran, S. (2014). COPRAS decision model to optimize blind spot in heavy vehicles: A comparative perspective. *Procedia Engineering*, 97, 1049-1059.
- Rules on traffic signs (2021). *Official Gazette of the Republic of Serbia*, 14/2021.
- Ross, H., & Plug, C. (2002). The Mystery of The Moon Illusion-Exploring Size Perception. *The Mystery of The Moon Illusion-Exploring Size Perception*, 288.
- Roy, B. Baromètre 2011 de la santé visuelle des Français. 2011.
- Škerović, V., Gordić, M., Galović, N., Djuretić, A. (2011). Visibility parameters as a key aspect of pedestrian crossing safety. *9<sup>th</sup> International Conference Traffic Safety in the Local Community*, Divčibare.
- Trifunović, A., Pešić, D., & Čičević, S. (2022). Experimental Study: Children's Perceptions Expressed Through Drawings and Coloring. *Perceptual and Motor Skills*, 00315125221104780.
- Trifunović, A., Pešić, D., Čičević, S., & Antić, B. (2017). The importance of spatial orientation and knowledge of traffic signs for children's traffic safety. *Accident Analysis & Prevention*, 102, 81-92.
- Vincent, D. S., Pitchipoo, P., & Rajakarunakaran, S. (2013). Elimination of blind spots for heavy transport vehicles by driver seat design. In *Int Conf Adv Manuf Auto, Kalasalingam University, India*.
- World Health Organization. (2014). Visual impairment and blindness, *WHO*.

## ACKNOWLEDGEMENTS

The authors acknowledge the constructive comments of two anonymous reviewers, which have helped to significantly improve this paper. This study was supported by the Ministry of Education, Science and Technological Development of Serbia (projects 36027, 36022 and 36006).

## BIOGRAPHY

**Aleksandar Trifunović** was born in Kragujevac, Serbia, in 1990.

He received a B.Sc. in traffic engineering and a Ph.D. degree in traffic safety from the University of Belgrade, Faculty of Transport and Traffic Engineering.

His main areas of research include traffic safety, new technologies, geometric modelling, etc.

He is currently working as an assistant professor at the University of Belgrade, Faculty of Transport and Traffic Engineering.



# OESEM

19<sup>th</sup> INTERNATIONAL CONFERENCE  
"MAN AND WORKING ENVIRONMENT"

OCCUPATIONAL AND ENVIRONMENTAL SAFETY  
ENGINEERING & MANAGEMENT

## *Safety Management and Sustainable Development*





IVANA BOGDANOVIĆ  
PROTIĆ<sup>1</sup>  
LJILJANA VASILEVSKA<sup>2</sup>

<sup>1,2</sup>University of Niš,  
Faculty of Civil  
Engineering  
and Architecture

<sup>1</sup>ivana.bogdanovic  
@gaf.ni.ac.rs

<sup>2</sup>ljiljana.vasilevska  
@gaf.ni.ac.rs

## SUSTAINABLE URBAN AGRICULTURE PRACTICE AND POSSIBILITIES OF ITS APPLICATION IN THE CITY OF NIŠ

**Abstract:** *Climate change, rapid urbanization, and the increase in pollution caused by decades of industrial production and industrial agriculture pose serious threats to cities around the world. Current urban theory and practice suggest that sustainable agricultural practices are a convenient and effective mode of overcoming these problems, which provides cities and their population with various benefits and contributes to sustainability. Types of urban agriculture are diverse and have a wide range of applications. The most significant benefits of their implementation are the following: contribution to the economy of food production, an increase of available food in urban areas, provision of local food production and reduction of distribution costs, prevention of extensive land degradation, reduction of harmful gas emissions and soil and air pollution, air temperature regulation, higher employment of citizens, contribution to social inclusion, reduction of health problems resulting from environmental pollution, creation of places for citizen interaction, encouraged social inclusion, interaction with nature, etc. This paper aims to investigate the possibilities of applying different types of urban agriculture, both in inherited large housing estates from the socialist era and those built in the post-socialist period in the city of Niš. For this purpose, in the theoretical part of the paper, foreign examples of good practices of urban agriculture are analyzed. The application of urban agriculture in selected areas is investigated and recommended in various types of urban agriculture: urban farms on balconies, rooftop gardens, green walls, and community gardens. This research is especially important in the context of comparing the spectrum of possible types of urban agriculture in the large housing estates from the socialist and post-socialist periods. The results of this research may be important for promoting the application of sustainable agricultural practices in our urban theory and practice in both the existing and the newly planned residential areas.*

**Key words:** urban agriculture, sustainability, large housing estate

### INTRODUCTION

The trend of a considerable increase in the world's population has been evident in recent decades, and it is especially pronounced in cities around the world (United Nations, 2018). Namely, only 14% of the population lived in cities 100 years ago, while today almost 50% of the world's population lives in urban areas. The UN predicts that the global degree of urbanization will continue to rise rapidly. According to their predictions, it is expected that as much as 70% of the world's population will live in cities by the middle of this century. In current conditions, cities around the world are already facing numerous problems such as poverty, environmental degradation, poor living conditions (access to safely managed drinking water, lack of durable housing, lack of secure tenure,

unemployment, etc.), and food insecurity. Food insecurity in urban areas is constantly increasing, as indicated by the fact that the percentage of the global population affected by food insecurity has increased from 22.4% in 2014 to 25.9% in 2019 (Ricardo, O. 2022). In many countries, in response to the problem of food insecurity, and to ensure adequate food supply and distribution systems to deal with rapid urbanization, urban policies and strategies are aimed at encouraging the development and application of urban agriculture (hereinafter UA). This is indicated in several researches, studies, and strategies (Kennard and Bamford, 2020; Lohrberg et al., 2016).

This research investigates the key characteristics of the UA concept and explores the potential for its implementation on the neighbourhood level in the case

of the city of Niš. In the first part of the paper, the emerging need for UA is discussed through examination of issues related to food security and urban population growth. In this part of the research, the benefits of UA application are also considered. In order to more comprehensively understand the wide range of types of sustainable urban agriculture (hereinafter SUA), this paper discusses examples of good practice in countries where SUA is represented through many years of practice and in which their further, more intensive application, is encouraged.

Despite the rich international as well as domestic practice of applying various types of UA, in the case of the city of Niš, the application of UA is absent. Accordingly, the final part of the paper focuses on exploring the possibilities of SUA implementation in large housing estates (hereinafter LHE) in the city of Niš, in the context of quality-of-life improvement and sustainability. The investigation is conducted in two selected LHE neighbourhoods: (1) Krive Livade, part of LHE Boulevard Nemanjića, built in the socialist era; and (2) the western part of LHE Somborska-Studenička, built in the post-socialist period. The level of neighbourhood is chosen as a research unit because the literature recognizes it as important for studying social and physical changes, as well as for investigating residents' use and perception of the urban environment and their participation in urban life, which is also important for SUA implementation. It serves as a basic element in the development of urban structure, provides for basic human needs, and helps strengthen local community ties. After a comparative analysis of the physical and functional characteristics of the selected neighbourhoods, their physical capacity for the SUA application was considered. The paper concludes with the comparison of the possibilities of applying SUA in different urban fabric conditions, which arose as a consequence of two different developmental, institutional and planning concepts – past (socialist) and present (post-socialist). The results of this research may be important for promoting the application of SUA practices in our urban theory and practice in both the existing and the newly planned residential areas.

## **URBAN AGRICULTURE – CONCEPT, BENEFITS AND TYPES**

Climate change, the need to save on classic fossil fuels, the ever-increasing world's population and the increase in demand for food, the reduction of the total area of agricultural land and the decrease in yields as a result of the expansion of cities, hyper-urbanization and the accelerated growth of urban population with a simultaneous economic and social crisis, the increase in pollution caused by decades of industrial production and industrial agriculture, a series of environmental problems in cities, as well as an increase in unemployment and demand for new types of occupations, pose serious threats to cities around the world. In the strategic and planning approaches and

practices of many countries, UA is often seen as an appropriate and effective mode of overcoming these problems (Kennard and Bamford, 2020; Lohrberg et al., 2016; Ackerman, 2011; Tillie, 2014). UA provides various benefits to the urban population, such as: contribution to the economy of food production, an increase of available food in urban areas, provision of local food production and reduction of distribution costs, prevention of extensive land degradation, reduction of harmful gas emissions and soil and air pollution, regulation of air temperature and prevention of heat islands (Tidball and Krasny, 2007). It also enables higher employment of citizens, contributes to social inclusion, reduces health problems resulting from environmental pollution, creates a place for citizens to interact, encourages social inclusion and interaction with nature, etc. These benefits are particularly recognizable and important for the sustainable development of residential areas.

In general, UA implies the practice of growing, processing, and distributing food within the cores of metropolitan areas and at their edges (van Venhuizen and Danso, 2007), and it can also include aquaculture, agroforestry, and horticulture. UA has emerged as one approach that effectively contributes to production, availability, and access to food in urban areas in the last decade, and it implies innovative food-production methods that maximize production in a small area, community-supported agriculture based in urban areas, and family farms located in metropolitan greenbelts (Kimberley, Campbell and Bailkey, 2011). The special importance of UA is reflected in the production of fresh and healthy food, as opposed to the increasing production and supply of GM food, unfavourable for human health. The multiple benefits of UA application can be seen in the socio-economic, scientific, environmental, educational, and cultural fields. UA can help the cities to improve the urban environment and become more resilient. SUA is conceptually different from classic agriculture, which is responsible for up to 30% of the world's greenhouse emissions, pollution of land, use of non-renewable energy sources, loss of land fertility, and increase in pesticide usage, which contributes to extensive land devastation. Furthermore, various studies have proven that UA contributes to urban poverty reduction, social inclusion and inclusion of marginalized communities (Kennard and Bamford, 2020). Some of the types of UA are being built on vacant, neglected, and previously devastated land. By creating UA on them, productive green areas are created, which enhances the vegetation cover in the city with important adaptive benefits. They significantly contribute to the reduction of pollution and air temperature regulation, without neglecting the primary benefit of locally produced food. Furthermore, UA can be used as a response to climate change (flooding, landslides). As UA is located in or near cities, the time and length of food transportation to the consumers is significantly reduced, and so is the emission of harmful gases. The technologies used by UA can reduce energy



consumption and waste deposits (de Zeeuw, van Veenhuizen and Dubbeling, 2011), as well as water consumption because the wastewater for irrigation is reused. By developing urban farms, creative places are made for citizen interaction that can contribute to encouraging social inclusion, reducing the vulnerability of specific urban groups and strengthening community-based adaptive management, enabling interaction with nature and encouraging self-expression, as opposed to imposed digitization, mass media, etc., which produce alienation from one's family and friends, and the weakening of social connections. The special importance of urban farms lies in the increased income of low-income households which want to engage in UA, and in a broader sense, it contributes to a more productive urban economy. Involvement in UA may lead to better nutrition, more physical exercise, an increase in self-esteem (de Zeeuw, van Veenhuizen and Dubbeling, 2011), and educational, youth development, and employment opportunities. Considering the aforementioned multiple benefits of UA, UA has a high potential to build more resilient cities and overall quality of life in urban areas.

In many countries, urban policy and development of urban farms have been developed and effectively implemented. The general typology of urban farms based on access includes private, community/public, and commercial urban farms (Kennard and Bamford, 2020). Subtypes within the above categories are given in table 1.

**Table 1.** *Types of urban farms*

Personal (private)	Community (public)	Commercial
Household gardens (backyard, balcony, indoor)	Community gardens (including gardens at places like schools, senior citizen homes)	Small urban farms (vacant lots, rooftops)
Subsistence growing (mini-farm)	Allotments	Indoor farms (inside buildings, shipping containers, warehouses)
	Easement / Right-of-way gardens	Vertical farms (visionary)
	Rooftop garden/ greenhouse	
	Urban foraging	
	Guerrilla gardening	
	Public food forests	

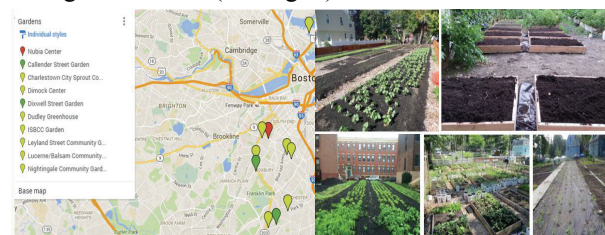
This paper focuses on non-commercial, private, and public UA types, such as: (1) micro-agriculture on balconies, roof terraces, gardens, and windows; (2) community gardens; (3) rooftop gardens; (4) green walls; (5) greenhouses; and (6) vertical farms

## URBAN AGRICULTURE – BEST PRACTICE EXAMPLES

In cities all over the world, there is an increasing trend of investment in building urban farms. In underdeveloped countries, where the problem of food demand is the most pronounced, initiatives for UA are directed towards the production of food for the growing population, while in developed countries the application of UA is more oriented towards social, economic, and ecological benefits (related to lifestyle, health, community development, and reduction of pollution). In order to include a variety of examples of good practice, the following text presents different types of urban farms, and some of the examples represent the synergy of the types from Table 1.

### NUBIA urban gardens in Boston

Nubian United Benevolent International Association (NUBIA) is a non-profit urban development located in Boston. It was founded in 2008 to reduce the impact of food insecurity in the Boston Metropolitan area and create an environment where families are able to learn how to be self-sufficient (<https://www.nubianet.net/>). In addition to producing locally grown food at affordable prices in the community, the goals of this organization are: training different age categories of residents to work in community gardens, involving children and teenagers, and creating a strong community in which young people are active leaders. NUBI's scope includes the development and promotion of SUA as a commercial sector that creates green jobs for residents. Involved local communities are also turning neglected public open spaces into successful urban farms, revitalizing city landscapes. In addition to UA on the ground floor, numerous rooftop gardens were built throughout Boston (see Fig. 1).



**Figure 1.** *Nubia urban gardens*  
Source: <https://www.nubianet.net/>

### Agricultural district Sunqiao in Shanghai

Shanghai, one of Asia's megacities with a high degree of hyper urbanization, greatly encourages innovative solutions to provide food for the region's growing population. Sunqiao Agricultural District is located between Shanghai's main international airport and the city centre (<https://worldlandscapearchitect.com/sunqiao-urban-agricultural-district-shanghai-china-sasaki/>). Spread over a 250-acre area, it represents an innovative type of vertical farm that produces leafy greens that form the primary type of diet for the people of China. In addition to food production in vertical farms, in this district high-rise housing, spacious public open spaces, commercial spaces restaurants,

greenhouses, and a science museum are planned, which are mutually integrated and encouraging for social engagement in the direction of affirming healthy food as the most important aspect of quality of life (see Fig. 2).



**Figure 2. Vertical urban farm in Shanghai**

Source: [https://worldlandscapearchitect.com/sunqiao-urban-agricultural-district-shanghai-china-sasaki/#.X4B94edS\\_cs](https://worldlandscapearchitect.com/sunqiao-urban-agricultural-district-shanghai-china-sasaki/#.X4B94edS_cs)

### Spark Centre in Singapore

Spark Centre is an environmentally friendly housing complex for elderly residents in Singapore, whose number is increasing (<https://sparkarchitects.com>). It is based on the concept of integrated vertical urban farming and retirement living facilities (see Fig. 3). Within the framework of vertical urban farms – residential buildings, it is planned to grow food products, and some residents of the complex are offered employment in them. In addition to growing healthy food, both on the green walls and the balconies of apartments, as well as in community gardens, it is particularly important that this complex offers a stay in a natural environment and can extend the life of senior citizens by improving their health and quality of life. In particular, the environmental benefits of applying green design and technologies that will reduce energy consumption, as well as the social nature of the socializing of tenants during collective gardening in community gardens, should be highlighted. The complex can be considered self-sustainable in terms of the production of most of the food needed by the residents of both this complex and those in the immediate surroundings, as well as in terms of the income of the tenants who would be employed in food production.



**Figure 3. Spark centre in Singapore**

Source: [http://www.sparkarchitects.com/portfolio\\_page/homefarm/](http://www.sparkarchitects.com/portfolio_page/homefarm/)

### Urban farm *Nature Urbaine* in Paris

Nature Urbaine (NU) is the largest urban farm in Paris. It is located in the city centre only 15 minutes from the Eiffel Tower. NU is planned as an aeroponic farm so that the plants absorb water and nutrients via a mist,

which reduced the use of water to 10% compared to classical agriculture .

(<https://www.lonelyplanet.com/articles/agropolis-urban-farm-paris>).

The cultivation of more than 30 types of vegetables and fruits with a yield of 2,000 pounds a day is planned on the 14,000 m<sup>2</sup> area of the rooftop garden on the roof of the six-story pavilion (see Fig. 4). In addition, 20 market gardens are producing more than 2,000 pounds of fruit and vegetables a day in season. Apart from the production of food for commercial purposes, the importance of this urban farm also lies in educational tours and team-building workshops for companies. The content of NU is of particular importance, specifically beehives, educational spaces and workshops, spaces for social events, a bar and a restaurant. Finally, within this farm, local residents are allowed to grow vegetables on 140 plots. A special benefit of this urban farm is its contribution to reducing pollution in the city centre of Paris, as well as fostering environmental and economic resilience.



**Figure 4. Nature Urbaine in Paris**

Source: <https://www.inexhibit.com/wp-content/uploads/2021/07/NU-Paris-worlds-largest-rooftop-urban-farm-aquaponic-columns-3.jpg>

In the analyzed examples of good practice, the multiple benefits of applying UA in residential areas are evident, as it improves the health of residents, their quality of life, preservation and affirmation of greenery in cities, and the sustainability of urban areas and cities.

## POSSIBILITIES OF APPLICATION OF URBAN AGRICULTURE IN THE CITY OF NIŠ, SERBIA – NEIGHBOURHOOD LEVEL

Despite the fact that depopulation, population aging, and migration are key development problems in Serbia, and although it occurs at a reduced pace and intensity compared to some other countries, the general trend of urban population growth is also present in Serbia (according to the 2011 census, 59.5% of the population lived in cities). Therefore, the question of how to provide quality food to the city population, especially to the population of large cities such as Niš, is rightly asked.

### Urban brief

Although stagnating in population, with 254,723 inhabitants in 2020 (Gavrilović, 2021) Niš is still the third largest city in Serbia, the macro-regional centre and the largest city in the Region of South and East Serbia, and the centre of the Nišava Administrative District.



During socialism, Niš was an important industrial centre in former Yugoslavia. Based on the East European housing model, LHEs with socially-owned flats became a dominant type of housing provision, especially in capitals, administrative and industrial centres such as Niš. Seventy percent of the current multi-story housing stock in Niš was built between 1960 and 1980, when numerous LHEs appeared on the city outskirts. In 1991, the first year of transition, the share of housing units within LHEs constituted 31.4% (Stambeni profil grada Niša, 2006). Similar to other industrial centres in Serbia, in the years after 1990 Niš experienced the collapse of its economy, when leading industrial enterprises crashed down and numerous privatizations of state-owned enterprises failed. The dramatic downturn of the urban economy also continued during the 2000s, followed by a multi-fold decrease in the city budget, a high level of unemployment, and a low average monthly income, keeping Niš far below the national average. Affected by economic decline and decreased budget for housing development, the housing sector in Niš also experienced regressive changes. The most important were the absence of public investment in housing development, the absence of investment in rental and social housing, and a twofold decrease in housing production. The transfer of housing policy monopolization led to private investors taking over the construction of multi-family residential buildings. The construction of multi-family housing in the post-socialist period is represented through the following modes: (1) reconstruction of the city core; (2) infill development; (3) larger scale construction on brownfield sites, including urban transformation and densification of inherited LHEs from the socialist era; and (4) new construction on greenfield sites on the outskirts of the city.

### Study area

The research platform for examining the possibility of implementation of UA types in the city of Niš comprises two chosen neighbourhoods: (1) the neighbourhood within LHE Boulevard Nemanjića, the largest LHE in Niš from the socialist era; and (2) the neighbourhood within Somborska-Studenička housing area, the largest on-going, newly built construction on greenfield sites on the city outskirts in the post-socialist period (see Fig. 5).



**Figure 5.** Chosen neighbourhoods

Source: <https://a3.geosrbija.rs/>

The first chosen neighbourhood was built in the socialist period. Part of the LHE Boulevard Nemanjića, the neighbourhood is bordered by Branka Krsmanovića and Pariske Komune streets from the southwest and Niš in the east, and the left bank of the river Nišava from the northwest (Fig. 5). It was built from the mid-1970s to 1980 as a spatial and functional entity based on the application of the CIAM principle and rigid socialist urban planning. Its synergy was manifested through a recognizable urban pattern, both on the level of the neighbourhood and the whole LHE – spatial over-scaling, mono-functionality, urban and architectural uniformity based on the repetition of similar urban-architectural composition, and generously dimensioned but poorly equipped public open spaces (hereinafter POS) (see Fig. 6a). However, the LHE and the chosen neighbourhood have been integrated into the wider central city zone in the past few decades, which led to their transformation into a multifunctional area with land use diversification even during the socialist period. In the post-socialist period, the observed neighbourhood underwent additional planned and unplanned transformations. In addition to the massive privatization of existing housing stock, the post-socialist environment, marked by unregulated planning conditions and relaxed legal culture, influenced the emergence of the following urban changes (Fig. 6): (1) multistorey extensions, in the form of additional stories or lofts on top of existing host buildings, with new flats for the market (Vranic, Vasilevska and Haas, 2016); (2) a quantitative and qualitative decrease of POS (Vasilevska, Vranic and Marinkovic, 2014; Bogdanović Protić, Mitković and Ljubenović, 2019; Bogdanović Protić, Mitković and Vasilevska, 2020); (3) the origin and expansion of ‘garage capitalism’ – small scale retailing and services through the transformation and adaptation of ground floor spaces of existing housing stock (Vasilevska et al., 2015); and (4) small scale extensions on the host buildings based on individual actions, in terms of construction of new balconies, transformation of common spaces into flats, flat roof upgrades, etc. While these changes are characteristic of most LHEs, this neighbourhood is characterized by the transformation of a neglected and devastated area along the Nišava River into the “Zelena oaza” (*Green Oasis*) park, which is often cited in the literature as a best practice example of participative urban planning approach (Fig. 6b).

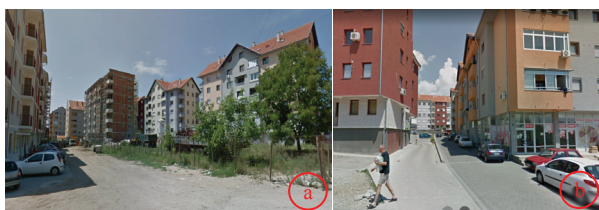


**Figure 6.** Neighbourhood within LHE Boulevard Nemanjića (socialist period). Current state.

Source: <https://www.google.com/maps>

The second chosen neighbourhood is a new ongoing housing development. It is a part of Somborska-Studenička housing area in the city municipality of

Pantelej (see Fig. 7). The construction of residential buildings began around 2000 and proceeded spontaneously as an investor-driven planning mode. In this neighbourhood, individual, detached high-rise housing buildings were built on what was previously agricultural land, while the accompanying urban services and corresponding POS were not provided and arranged. The consequence of urban transformations of this part of the city is its transformation from a zone of a rural character into a new city district, with mutually incompatible structures from a visual-aesthetic point of view (see Fig. 7a). The key feature of this neighbourhood is the large number of floors of the buildings and the non-observance of the minimum required distances according to the insolation conditions, which is reflected in the dimensions of the surrounding open spaces (see Fig. 7b). What is particularly problematic is that POS are either completely unorganized or omitted (Bogdanović Protić, 2016). They represent empty spaces between buildings and they mostly have very small areas without utility potential for residents' activities in the immediate living environment. All this is negatively reflected in its potential for good neighbourly relations, a sense of territoriality, and the residents' belonging to the residential environment.



**Figure 7.** Neighbourhood within LHE Somborska-Studenička (post-socialist period). Current state.

Source: <https://www.google.com/maps>

### Possibilities for UA implementation – Results and discussion

The analysis of the urban-architectural structure of the first neighbourhood indicated that, despite the significant urban changes and densification of the area in the post-socialist period, there is still a physical capacity of the space for the application of new contents, including different types of UA. The reason for this is the initial characteristics of the area, above all the generously dimensioned POS. Bearing this in mind, the research indicates the possibility of applying the following types of UA (Fig. 8): (1) small community gardens (collective gardens) for growing vegetables, herbs, and/or flowers in existing inter-block POS (inner courtyards, Fig. 8a); (2) education garden – children's garden, Fig. 8b); (3) private UA on balconies and terraces of existing buildings (Fig. 8c); (4) greenhouse (Fig. 8d); (5) vertical green walls on the south-west oriented facades of buildings (Fig. 8e); and (6) rooftop gardens on buildings that have retained a flat roof (Fig. 8f).

Community or allotment gardens could be placed in the POS and gardened by a group of residents. Private UA on balconies, roof terraces, gardens, and windows

would imply the production of agricultural crops such as vegetables, fruits, herbs, and flowers. Rooftop gardens could be used to insulate buildings, reduce stormwater flows, and potentially provide space for birds, bees, and people to congregate (Ricardo, 2022).



**Figure 8.** Neighbourhood within LHE Boulevard Nemanjića (socialist period) – Illustration of possibilities for UA types implementation

Sources: map: <https://a3.geosrbija.rs/>; a. b. <http://fundacijamy.com/english/projects-foundation-we-poland/community-gardens/>; c. <https://indiagardening.com/featured/best-plants-for-balcony-garden/>; d. <https://www.gardeningknowhow.com/special/urban/urban-garden-problems.htm>; e. <https://greenerideal.com/news/building/1101-green-walls-saving-urban-areas/>; f. <https://zinc-co-usa.com/systems/urban-rooftop-farming/>;

The analysis of the characteristics of the second neighbourhood indicates the limited possibilities of applying a wide spectrum of UA, primarily due to the key characteristics of the urban-architectural structure, such as exceeded occupancy index and floor area ratio, construction of individual residential buildings without fitting into the surrounding environment, insufficient distance between buildings, often below the minimum allowed values, absence of POS, lack of private open/green spaces, etc.

From the standpoint of this research, the following UA types can be implemented in this neighbourhood (Fig. 9): (1) small urban garden (Fig. 9a); (2) urban farm in the restaurant in the basement of the housing (Fig. 9b); (3) green walls on the south-west oriented facades of buildings (Fig. 9c); and (4) private urban farm on balconies and terraces of existing buildings (Fig. 9d). Rooftop gardens are not possible as all the roofs are pitched. The application of green walls is limited to particular buildings along Studenička street, due to the orientation and small distance between the buildings.



Green walls could be used as an extra space to grow plants, both internally and externally (Ricardo, 2022).

Small distances between buildings, small areas of open spaces, and the dominance of parking lots around buildings are only some of the reasons that there are much fewer opportunities in this area for the application of UA compared to the observed neighbourhood 1 from the socialist era.



**Figure 9.** Neighbourhood within LHE Somborska-Studenička (post-socialist period) – Illustration of possibilities for UA types implementation

Sources: map: <https://a3.geosrbija.rs/>; a. <https://my-redeem.com/2021/10/10/ephesians-5-part-1/>; b. <https://www.decoist.com/2013-10-17/moyo-restaurant-urban-farm-cape-town/sustainable-aquaponic-farming-at-the-moyo-restaurant/?chrome=1>; c. <https://israelbetweenthehines.com/2020/12/24/vertical-urban-farming-on-the-market/>; d. <https://harvesttotable.com/10-tomatoes-for-small-spaces-decks-patios-balconies/>

The assumption is that in the case of both neighbourhoods, the application of the mentioned types of UA contributed in the following ways: improvement of the existing public open spaces; growing of healthy food in the immediate surrounding of flats; employment of tenants; involvement of children, youth, and the elderly, and strengthening of good neighbourly relations and residential communities; education of citizens about the importance of UA; reduction of antisocial behaviour; increased sense of belonging to the residential environment; reduction of pollution; cooling of buildings; and beautification, enhanced visual identity, and improvement of the overall aesthetics of the space.

## CONCLUSION

It can be concluded that urban agriculture is a current and multifaceted mechanism for the quality-of-life improvement in urban areas, which has found wide application in cities around the world. Apart from the production of healthy food for the growing urban population, the importance of UA is recognized through a series of ecological, social, economic and visual-aesthetic benefits. From the analysis of the examples of good practice, it is concluded that the

range of application of UA is expanding and that it is important both within residential areas, the wider city core, and within educational and commercial institutions. Equally important is the commercial application in the form of new physical structures based on the principle of vertical gardens.

The conducted research has shown that the application of certain types of UA is possible in residential areas in Niš in theory, but very limited in practice. The research showed that inherited LHEs have greater possibilities for incorporating UA primarily due to adequate spatial opportunities for the introduction of various types of UA, which is the main limiting factor for implementation in areas from the post-socialist period.

A more detailed examination is necessary for the wider application of UA at the city level, both for existing areas and for the newly planned ones. Considering the identified benefits of UA, in the case of new construction of multi-family residential buildings, it would be desirable to designate locations for UA of larger dimensions as part of the Master plan of Niš, and concrete guidelines should be elaborated through detailed regulation plans. It would be especially important to mandate the construction of green roofs through regulations in the case of flat roofs, which could contribute to wider and easier application of rooftop gardens.

Regardless of the identified potential for the introduction of UA in LHEs in the city of Niš, its realization is not possible in the current conditions for several reasons: undefined ownership relations concerning POS in residential complexes inherited from the socialist era; lack of interest of local authorities in assigning POS to tenants for use; absence of promoting the importance of UA and educating the citizens concerning the possibilities of UA application; lack of financial instruments that local authorities would allocate for co-financing UA; insufficient citizens' awareness of the need to introduce UA and the importance of implementing UA in the context of mental and physical health.

Bearing in mind the identified institutional and financial problems and the problem of lack of awareness of the importance of UA on the part of local authorities and tenants, it can be concluded that in order to apply UA in the city of Niš, it is necessary to educate local authorities, appeal to citizens' awareness, and consider the possibility of applying UA through regulations in inherited LHEs from the socialist era and allocate funds for its implementation. In addition, private investors should be made aware of the importance of UA and provided with benefits for investing in UA in future constructed LHEs. Changes and improvements of the regulations and the introduction of UA in the planning documents, which would provide for certain types of UA in future LHEs, are particularly significant. Cooperation with countries where UA is widely developed and application for financial aid would also be of great importance for UA



application. Urban agriculture is one of the most important instruments for achieving sustainability and resilient urban areas, and its affirmation and intensive application should be one of the key goals that cities in Serbia should strive for in the near future.

## REFERENCES

Ackerman, K. (2011). *The potential for urban agriculture in New York City: Growing capacity, food security, & green infrastructure*, Urban Design Lab at the Earth Institute Columbia University, Columbia University

Bogdanović Protić I. (2016). *Definisanje modela revitalizacije slobodnih prostora kompleksa sa višespratnim stanovanjem u funkciji unapređenja kvaliteta života*, doktorska disertacija, Univerzitet u Nišu, Građevinsko arhitektonski fakultet, Niš.

Bogdanović Protić, I., Mitković, P., Ljubenović, M. (2019). Criteria and aspects of quality of open spaces in high-rise housing neighbourhoods in the process of urban revitalization”, *Facta Universitatis. Series: Architecture and Civil Engineering*, Vol,17(2), pp. 221-233.

Bogdanović Protić, I., Mitković, P., Vasilevska, Lj. (2020). Toward regeneration of public open spaces within large housing estates—A case study of Niš, Serbia, *Sustainability*, Vol. 2(24), pp. 10256

de Zeeuw, H., van Veenhuizen, Rene & Dubbeling, Marielle (2011). The role of urban agriculture in building resilient cities in developing countries. *The Journal of Agricultural Science*. 149. pp. 153 - 163. 10.1017/S0021859610001279.

Hodgson, K., Campbell, M.C. and Bailkey, M., (2011). *Urban agriculture: Growing healthy, sustainable places*. American Planning Association.

<https://www.lonelyplanet.com/articles/agropolis-urban-farm-paris>-[Accessed 20 Jun 2022].

<https://www.nubianet.net/>-[Accessed 19 May 2022].

<https://sparkarchitects.com/work/home-farm>-[Accessed 12 Jun 2022].

<https://worldlandscapearchitect.com/sunqiao-urban-agricultural-district-shanghai-china-sasaki/> -[Accessed 3 Jun 2022].

Kennard, N. J., Bamford, R. H. (2020). Urban agriculture: opportunities and challenges for sustainable development, *Zero Hunger*, pp. 929-942

Lohrberg, F., Lička, L., Scazzosi, L. and Timpe, A. eds., (2016). *Urban agriculture Europe* (p. 231). Berlin: Jovis.

Gavrilović, D. eds. (2021). Municipalities and regions of the Republic of Serbia (Serbian), Statistical Office of the Republic of Serbia, Beograd, available: <https://publikacije.stat.gov.rs/G2021/pdf/G202113048.pdf>

Ricardo Orlando (2022). Common Types of Urban Agriculture <https://www.urbanfarmonline.com/common-types-of-urban-agriculture/> [accessed 10 July 2022].

Stambeni profil grada Niša, Javno preduzeće Gradska stambena agencija Niš, 2006, Niš

The Sustainable Development Goals Report 2020: <https://unstats.un.org/sdgs/report/2020/#sdg-goals>[Accessed 14 May 2022].

Tidball, K.G. and Krasny, M.E., (2007). From risk to resilience: What role for community greening and civic ecology in cities. *Social learning towards a more sustainable world*, pp.149-164.

Tillie, N., Kirsimaa, K., van de Dobbelsteen, A. and Sijmons, D., (2014). Urban Agriculture in Rotterdam: potentials for a liveable, low-carbon city and sustainable phosphorus flows. In *Why we need small cows: Ways to design for urban agriculture* (pp. 137-163). VHL University of Applied Sciences.

United Nations (2018). News: 68% of the world population projected to live in urban areas by 2050, says UN <https://www.un.org/development/desa/en/news/population/2018-revision-of-world-urbanization-prospects.html> [Accessed 2 July 2022].

Van Veenhuizen, R., Danso, G.: *Profitability and sustainability of urban and peri-urban agriculture*, FAO, 2007, Rome

Vasilevska, L., Milanovic, D., Nikolic, M., Vranic, P. and Milojkovic, A., (2015). „Garage capitalism” as a form and process of post-socialist urban changes: Its pace, intensity and structural characteristics. A case study of Nis, Serbia. *Habitat International*, 48, pp.149-158.

Vasilevska, L., Vranic, P. and Marinkovic, A., (2014). The effects of changes to the post-socialist urban planning framework on public open spaces in multi-story housing areas: A view from Nis, Serbia. *Cities*, 36, pp.83-92.

Vranic, P., Vasilevska, L. and Haas, T., (2016). Hybrid spatialities: Multi-storey extensions of socialist blocks of flats under post-socialist transition in Serbia, the case of Nis. *Urban Studies*, 53(6), pp.1261-1277.

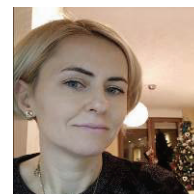
## BIOGRAPHY

**Ivana Bogdanović Protić** was born in Niš, Serbia, in 1976.

She received a diploma in architectural engineering and a Ph.D. degree in urban planning from the University of Niš, Faculty of Civil Engineering and Architecture.

Her main areas of research include urban development, urban planning, urban design, urban sustainability, landscape, urban open spaces, etc. She is the author of several papers in international journals with an impact factor, over 30 papers in conference proceedings, several papers in national journals, and one student’s textbook.

She is currently working as an Associate Professor at the Faculty of Civil Engineering and Architecture in Niš, University of Niš.



VESNA NIKOLIĆ<sup>1</sup>  
TAMARA VUKIĆ<sup>2</sup>

<sup>1,2</sup> University of Niš,  
Faculty of Occupational Safety

<sup>1</sup>vesna.nikolic@znrfak.ni.ac.rs

<sup>2</sup>tamara.vukic@znrfak.ni.ac.rs

## DIDACTIC AND METHODOLOGICAL DISCOURSE OF EDUCATION FOR SUSTAINABLE DEVELOPMENT

**Abstract:** Investing in education for sustainable development is essential for making changes in knowledge, behavior and lifestyles necessary for sustainable development. Learning can be combined with the transformative power of nature to help raise climate awareness, transition to a circular economy and a sustainable future. In order to achieve the sustainable development goal 4.7, it is necessary to provide appropriate didactic and methodological paths and resources in education for sustainable development. Education for sustainable development requires innovative didactical and methodological approaches that foster active student participation in the teaching process, creativity, inventive skills and imagination, as well as a focus on the search for solutions to contemporary problems, etc. Accordingly, the approaches and methods suitable for the implementation of teaching and learning in the field of education for sustainable development will be presented in the paper.

**Key words:** sustainable development, education, didactics, methodology

### INTRODUCTION

Sustainable development is one of the biggest challenges for modern education. A path towards development that meets the need of the present without compromising the ability of future generations to meet their own needs (WCED, 1987) requires the transformation of society towards peace and sustainability. Sustainability as a paradigm for thinking about the future where environmental, societal and economic considerations are balanced in the pursuit of improved quality of life (Carpentier & Braun, 2020) requires not only a change in learning and curriculum but also a change in the educational paradigm – a paradigm that indicates a change in epistemology, from reductionism to holism and from relativism to relationalism. The various points-paradigm of development and the paradigm of education, as observed by Sarabhai (2015) are interrelated and form part of a single paradigm shift that is needed as we move towards education for sustainable development.

Globally, numerous international activities and documents, starting from "Our Common Future", through Agenda 21, the Decade of Education for Sustainable Development, Agenda 2030 and numerous declarations (more recently the Incheon Declaration, the Berlin Declaration) promote the vital role of education for sustainable development in the transformation of society and the economy towards sustainability. To date, ESD has been integrated into many global frameworks and conventions on key sustainable development topics. For example, Article

13 of the Convention on Biological Diversity, and its work programmes; the Hyogo Framework for Action 2005-2015: Building the Resilience of Nations and Communities to Disasters and the subsequent Sendai Framework for Disaster Risk Reduction 2015-2030; Sustainable Lifestyles and Education Programme of the 10-Year Framework of Programmes on Sustainable Consumption and Production 2012-2021; Article 6 of the United Nations Framework Convention on Climate Change and Articles 11 and 12 of the Paris Agreement, etc.

The increased interest of the scientific and professional public in education for sustainable development shows that perhaps it is the right moment to direct the research attention towards the didactic and methodological aspects of this issue. The transformative nature of education for sustainable development requires innovative didactic and methodological approaches that will enable students to understand and respond to a world that is being changed as a result of the implementation of sustainable development. It is about training the "sustainably" responsible and active citizens, the so-called "sustainable citizens" (the term *sustainability citizenship* is commonly used in modern literature) with expressed pro-sustainable behavior both privately and professionally (UNESCO 2017; Wals & Lenglet 2016).

### THEORETICAL BACKGROUND

Education/learning for sustainable development produces learning outcomes that include core

competencies in: foresighted thinking, an interdisciplinary work approach, a cosmopolitan perception, transcultural understanding and cooperation, participatory skills, planning and implementation, a capacity for empathy, compassion and solidarity, self-motivation and motivating others, and a distanced reflection on individual and cultural models (Barth et al., 2007). Therefore, it is not a matter of simply transferring knowledge “about sustainable development” – the purpose of education for sustainable development is more related to changing attitudes and behavior. Accordingly, students should be freethinking, adaptable and independent learners who are empowered to direct their own learning and practice (Cutting, 2016). This cannot be achieved by relying on traditional teaching methods and approaches that place students in the position of passive listeners, such as the classic lecture method that puts the teacher in the foreground as the only source of information. As stated by Tilbury & Cooke (2005), education for sustainable development challenges the role of the educator and seeks to break down the traditional teacher-student hierarchy in the classroom. It must be based on collaborative learning environments in which the goal is not exclusively to transfer knowledge but to build students’ capacities. Similarly, in the UNESCO publication “Framework for the UNDES International Implementation Scheme” it is stated that “teaching that is geared simply to passing on knowledge should be recast into an approach in which teachers and learners work together to acquire knowledge and play a role in shaping the environment of their educational institutions” (UNESCO, 2006). This can be illustrated by the characteristics of teachers in teaching and learning for sustainable development, given by Vrbanec, Garašić and Pašalić (2011). Namely, in education for sustainable development, teachers are open to listening, they appreciate students’ concerns, experiences, ideas and expectations, they are “flexible” and open to change when planning the teaching process, and they encourage collaborative and experiential learning. Teachers base the teaching process on practical activities and try to connect them with the students’ development of ideas (concepts) and theories, they create the conditions for students’ participation and ensure the climate for the development of students’ own ways of learning, ideas and views. In addition, the ways of evaluating the students’ achievements are in accordance with the mentioned criteria (Vrbanec et al., 2011).

Accordingly, it can be concluded that education for sustainable development requires innovative, collaborative and co-creative teaching methods based on designedly ways of thinking (Androustos & Brinia, 2020), i. e. methods that promote socio-ecological problems and encourage critical thinking and exchange of information and ideas (García-González et al., 2016). As stated in the “Framework for the UNDES International Implementation Scheme” (UNESCO, 2006), there is a need for multi-method approach, via

the use and combination of different pedagogical approaches. ESD highlights the need for alternative and student-activating methods for teaching and learning. This is aimed at challenging students to participate actively, think critically, and reflect. A switch to alternative methods of teaching can provide a better education for sustainable development (UNESCO, 2012).

## **METHODOLOGY**

The desktop research was conducted with the aim of identifying didactic and methodological issues and particularities in education for sustainable development. Databases that were used include Google Scholar, KoBSON, Science Direct and UNESCO Library, and the following keywords were searched: ESD teaching, ESD teaching approaches, ESD teaching methods, ESD teaching pedagogies, ESD teaching methodology, and ESD didactics. The gathered literature covered a range of subjects, from which the papers in the referenes section were chosen. The analysis of these papers helped establish two directions of the research, which served as the basis for defining the following research tasks: (1) to identify methodological approaches that are suitable for education for sustainable development and their characteristics (2) to present the particularities of teaching approaches and methods suitable for education for sustainable development.

## **METHODOLOGICAL APPROACHES IN EDUCATION FOR SUSTAINABLE DEVELOPMENT**

The analysis of relevant literature and documents indicates that there are plenty of methodological approaches in education for sustainable development. The selection of methodological approaches and variants depends on the target (pedagogical and educational goals) and the specifics of the situation (learners, teachers, or the learning environment) in which they will be used. The variation in pedagogical approaches offered is also important: given the diversity of students (e.g., gender or cultural background) within a program, it is desirable and necessary to use various approaches. A diversity of approaches allows students to employ and develop different learning processes, making them grow as learners and enhancing their skills and capacities to learn and think (UNESCO, 2012).

In general, all approaches can be divided into (Lozano et al., 2017):

- *Universal*: broadly applicable pedagogies that have been used in many disciplines and contexts (case studies, interdisciplinary team teaching, lecturing, mind and concept maps, and project and/or problem-based learning);
- *Community and social justice*: pedagogies developed specifically for use in addressing social justice and

community-building (community service learning, jigsaw/interlinked teams, participatory action research);

- *Environmental education*: pedagogies emerging from environmental sciences and environmental education practices (eco-justice and community, place-based environmental education, supply chain/Life Cycle Analysis, and traditional ecological knowledge).

According to Scoullos & Malotidi (2004), the basic characteristics of methodological approaches in this area are as follows (Basic Elements for the UNECE Strategy for Education for Sustainable Development, 2003, according to Scoullos & Malotidi, 2004, p. 39-41):

- *Action-orientation* – students are seen not only as learners but also as “doers” and change agents; it is recommended to include them in environmental protection activities (independently or in cooperation with parents, the community, youth clubs, NGOs, etc.). This will contribute to the development of students’ action competencies, but also to the achievement of short-term and long-term changes in the field of sustainable development;

- *Development of critical thinking* – it is important to apply approaches that promote an open mind in both learners and teachers, particularly for sustainable development issues that involve a number of views and dimensions (cultural, economic, ecological, political, social, etc.), and encourage cognitive skills and “creative thinking” that leads to a deeper understanding and willingness to undertake action;

- *Democratic principles and processes* – young people can make significant unique contributions and provide original perspectives on sustainable development issues, which is why it is important to actively include them in decision-making processes; ESD programs and activities should be based on and promote democratic principles, as well as require participatory processes for their implementation;

- *Holism* – students are seen as “whole” personalities, including not only their skills and knowledge, but also their needs, motivation, emotional and other characteristics;

- *Interdisciplinarity and multidisciplinary* – the emphasis is on the connection between different perspectives; while multidisciplinary refers to observing problems from different disciplinary perspectives, but not necessarily integrating them into one single framework, interdisciplinarity includes two or more scientific disciplines and implies their cooperation and integration;

- *Use of modern ICT* – information and communication technologies are seen as a tool, rather than as an independent teaching method; their application in the teaching process facilitates access to information, learning materials, and best educational practices across all sectors and disciplines;

- *Problem-based learning* – teaching and learning are organized around a specific issue and/or problem

(preferably a local one) whose solution is the ultimate goal; problems from the real world are used as a means to motivate and initiate students’ learning processes, while simultaneously developing their personal competencies (skills, critical thinking, etc.);

- *Project work* – it is characterized by students’ initiatives, action-orientation, interdisciplinarity, group work, and joint planning (of teachers and students); the topic for the project should be derived from the local context by selecting relevant knowledge and information.

In the publication “Handbook on Methods used in Environmental Education and Education for Sustainable Development” (Scoullos & Malotidi, 2004) a goal-oriented framework for choosing the teaching methods in education for sustainable development is given (Table 1).

**Table 1.** Goal-oriented framework for choosing the teaching methods in ESD

Goal domain	Suggested methods
<b>Awareness &amp; knowledge</b> Developing awareness of the environment, society, economy and their interdependence; understanding the connection between environmental degradation, poverty, unsustainable patterns of production and consumption, gender inequality, human rights violations	Lecture & discussions Bibliographic research & use of modern ITCs Experiments Field visits & trips Case study Surveys
<b>Behaviour, attitudes &amp; values</b> Encouraging care for the environment and society, strengthening the values of respect for nature, equality, peace, tolerance and democracy, motivating students to actively involve themselves in environmental protection and improving the quality of life (especially of the poor, women, victims of racism, cultural and ethnic minorities, etc.)	Panel discussions & debates Surveys Roleplay Case study Fieldwork & research Projects carried out in cooperation with schools from other communities, or even from other countries
<b>Skills</b> Acquiring skills for investigating and identifying environmental, social and economic problems, and addressing them through appropriate decisions and actions	Panel discussions & debates Role play & simulation Surveys Problem-solving approaches Projects

<p><b>Involvement in creative action</b>                  Creating opportunities for students' active involvement in joint and independent work on solving problems and issues in their community</p>	<p>Workshops with community resource people                  Problem-solving approaches                  Projects carried out in cooperation with other schools, local institutions (e.g., environmental education centres, NGOs), and community stakeholders</p>
---	---

(According to Scoullos & Malotidi, 2004, p. 44)

Some authors (Frisk & Larson, 2011) chose the approaches and methods in ESD based on key competencies for sustainability (Table 2).

**Table 2.** Key competencies and approaches for sustainability education

Sustainability competencies	Educational pedagogy
<p>Systems thinking and an understanding of interconnectedness</p>	<p><i>Concepts:</i> interconnections among the environment, economy and society (influences, trade-offs, feedbacks, unwanted consequences of individual and collective actions)  <i>Methods:</i> <b>real-world case studies with place-based lessons and activities; interdisciplinary approaches to problem-based learning</b></p>
<p>Long-term, foresighted thinking</p>	<p><i>Concepts:</i> future orientation - achieving intergenerational equity, reducing the long-term impacts of human actions, realizing societal visions of the future and developing transition strategies and evaluative techniques  <i>Methods:</i> <b>visioning exercises; forecasting &amp; backcasting activities</b></p>

<p>Stakeholder engagement and group collaboration</p>	<p><i>Concepts:</i> democratic decision-making, including intragenerational equity in participation and consideration of plural perspectives and transdisciplinary collaborations  <i>Methods:</i> <b>community-based service learning; role playing activities such as mock citizen jury or conflict resolution; group projects and collaborative activities</b></p>
---	---

<p>Action-orientation and change-agent skills</p>	<p><i>Concepts:</i> transformational consumer actions, along with civic and community engagement  <i>Methods:</i> <b>experiential lessons including project-based learning, community service-learning and place-based activities; commitment pledges</b></p>
---	---

(According to Frisk & Larson, 2011)

When it comes to methods and approaches in education for sustainable development, the following recommendations can also be found in the professional and scientific literature: mentoring, facilitation, participative inquiry, action learning and action research (Tilbury & Cooke, 2005); word, art, drama, debate, experience (UNESCO, 2006); problem-solving and projects, cooperative learning, discussions, field trips, experiments (Scoullos & Malotidi, 2004); PBL (problem-based learning) (Steinemann, 2003); PPBL (problem- and project-based learning) (Brundiers & Wieck, 2013); active learning (Svilengačanin i Bojić Perkin, 2020); student-centered learning, minds-on and hands-on learning, active participation (Elliam & Trop, 2011); fieldwork, survey, audits, drama, role-play, debate, stories, mini-lessons, reading, writing, experiments, action projects, deliberation, group-discussions, problem-solving (Rosenberg, 2009) etc. Despite the multitude of diverse approaches and methods in teaching and learning for sustainable development, it is clear that all of them essentially require students who will be active, creative and critical in the learning process. These students will learn through experience, expand their knowledge through practical activities, projects, and experiments that are designed to address regional and global issues related to sustainable development.

### METHODOLOGICAL PARTICULARITIES OF EDUCATION FOR SUSTAINABLE DEVELOPMENT

The basic features of teaching approaches and methods that are considered “general” or fundamental in



education for sustainable development are presented in Table 3: active, cooperative, problem-based, project-based and experiential learning, as well as research and experiments, discussion and debate, role play, and case study.

**Table 3.** *The particularities of teaching approaches and methods suitable for education for sustainable development*

ACTIVE LEARNING/TEACHING
Active learning can be defined as “anything course-related that all students in a class session are called upon to do other than simply watching, listening and taking notes“ (Felder & Brent, 2009). It represents a contrast to the traditional way of teaching where students passively receive information from the teacher. Active learning is based on two elements: student activity and involvement in the learning process (Prince, 2004). Students are encouraged to work independently, with curiosity, and to discover the connection between new and previously acquired knowledge (Svilengačanin i Bojić Perkin, 2020). This type of learning provides a high degree of students’ autonomy and self-monitoring, the application of different mental strategies and specific cognitive skills for distinguishing important and irrelevant information, analyzing and comparing, building knowledge based on previous experience, and critical thinking (Ledić, 2006, according to: Peko & Varga, 2014). In communication with students, the teacher uses expressions such as: explain, interpret, compare, notice similarities and/or differences, prove, explain, design, plan, apply, show, etc. The teacher is a guide, interpreter, collaborator and experienced helper (Svilengačanin i Bojić Perkin, 2020).
COOPERATIVE LEARNING/TEACHING
In cooperative learning, students are divided into smaller groups in which they are responsible for their own success. The groups receive instructions for work and have the opportunity to join the discussion after receiving the working materials. Cooperative learning helps students develop specific skills, such as active and tolerant listening, helping others master the material, giving and receiving constructive criticism and managing disagreements (Simić, 2015). The teams are encouraged to talk to each other during collaborative work in order to exchange information about how each group is doing with achieving its objectives, whether there are still strong bonds between group members, etc. The teacher’s task is to provide enough time for work, to ensure that the procedure would be very specific, rather than general, to maintain the active participation of all students, to encourage them to develop collaborative skills, supervise and facilitate students’ work, to ensure that expectations/goals are presented clearly, and make sure results are reached and communicated (Scoullos & Malotidi, 2004).

#### PROBLEM-BASED LEARNING/TEACHING

Problem-based learning represents a set of learning experiences that involve students in complex projects and the real world, through which they develop and apply skills and knowledge (Segalàs et al., 2010). Students are faced with a real-world problems, similar to those they will encounter in their professional work. They take ownership of the problem and the problem-solving process, while teachers take the role of cognitive trainers (Steinmann, 2003). Problem-based learning has several steps: (1) discussion and topic definition by the teacher/students, exchange of information and experiences in order to answer the questions “Does everybody know/understand what the problem is? What do we know about it?”; (2) exploring the possible causes and impacts of the problematic situation through time; (3) identifying possible solutions, presenting the alternatives while considering the positive and the negative sides; (4) evaluation of alternative solutions, joint decision-making on the option which will be followed; (5) acting upon the solution, creating a plan and guidelines, encouraging the participation of the parties that need to be involved (Scoullos & Malotidi, 2004).

#### PROJECT-BASED LEARNING/TEACHING

Project teaching is a teaching model oriented towards building and developing students’ knowledge and abilities through their involvement in research projects. Most often, the activities that involve problem-solving tasks, creating a research project, and its implementation are designed. The teacher facilitates and directs learning, encourages students’ creativity and provides help in overcoming the existing situation and achieving progress in the development of abilities (Ристановић, 2019). Project implementation has the following phases: (1) choosing the topic – defining the topic and the general objectives of the project; (2) setting the framework – objectives and activities, group setting, timetable, allocation of tasks; (3) implementation – group and individual work, elaboration of findings/outcomes, synthesis of group work; (4) presentation – oral, written, artistic, informing local society, events; (5) assessment – work assessment and group assessment (Scoullos & Malotidi, 2004).

#### EXPERIENTIAL LEARNING/TEACHING

Experiential learning is based on facing the problems that need to be solved. Learning should not be perceived as an end goal, but rather as a process that leads to something useful and meaningful. Students learn by exploring ways to solve a problem, setting themselves, and their teacher, the tasks that will get them to the solution. Elements of experiential learning are: presentation of a task that needs to be solved, action planning, implementation of the action plan, reflecting on the learning process and presenting the results. The teacher takes the role of a mentor or a coach by doing the following: monitoring how the students manage to overcome problems; not offering ready-made solutions, but rather advising and partially facilitating the tasks; observing students as they work and evaluating their working process and achievements; serving as a source of information in terms of providing short instructions at the request of students (Gollob et al., 2010).

---

#### RESEARCH AND EXPERIMENTS

---

Research is based on the active involvement of students in solving a specific question through the design and implementation of research on the given problem (Cvetković et al., 2015). Through research, students learn to select and classify important information, as well as to choose the best solutions and research strategies. A particularly important goal of research is the development of divergent thinking and creative behavior by proposing a large number of ideas, observing problems from different angles and creating original solutions (Šefer i sar., 2012).

An experiment is a form of inquiry that can be conducted in the classroom. Expensive equipment and apparatus are not always necessary for experimentation (Rosenberg, 2009), while data is collected through interaction with common laboratory materials, data simulation tools, or a decision making environment, as well as a series of questions that lead to discovery-based learning. During the experiment, the teacher takes the role of a facilitator, asks leading questions and directs the students' attention to interesting results (What are classroom experiments?, n.d.).

---

#### DISCUSSION AND DEBATE

---

Discussion can be defined as a free verbal exchange of ideas between group members or between a teacher and a student. In order for a discussion to be effective, it is desirable that students have prior knowledge and information about the selected topic (Sajjad, 2010). In addition, the development of the discussion requires differences in opinions, attitudes and beliefs about certain issues and problems. There are different forms of discussion, such as direct discussion, discussion in small groups, panel discussion, etc. It has several stages: preparation of the discussion, introduction or initiation of the discussion, leading or shaping the discussion, concluding or reaching the goal (Nikolić, 2017).

A debate is a formal discussion in which two opposing parties exchange arguments belonging to different points of view on a certain topic, respecting pre-agreed rules. The standpoint to be represented is usually assigned to students. The purpose of this method is the development of communication and debating skills, confronting arguments, speech culture and the ability to quickly analyze, conclude and use professional argumentation (Cvetković et al., 2015). Each debate has the following steps: preparation of the debate and classification of students into groups (positional, oppositional and neutral); conducting the debate; and evaluation of the debate (Mikanović, 2012).

---

#### ROLEPLAY

---

Roleplay is a learning process in which participants assume the roles of other individuals in order to develop certain skills or achieve certain goals (Segalàs et al., 2010). Within the roleplay, both participants and observers have the opportunity to "put themselves in the others' shoes", i.e. to empathize, to better understand experiences, context and complexity of problems; their communication skills, as well as the ability to think critically and creatively, are strengthened (Rosenberg, 2009). They engage in a discussion about the causes of a given situation, the role of each of the characters, the implications of different stakeholders and possible solutions (Scoullos & Malotidi, 2004). When planning the roleplay, the teacher should: define the goals, choose the topic, select the participants and observers and give them instructions, and pay attention to acting in the situation, activation of the group, use of available space, discussion and assessment of the situation after the completed activity, as well as the exchange of experiences and generalization of the observations (Hyppönen & Lindén, 2009).

---

#### CASE STUDY

---

Case study refers to the study and analysis of cases that represent different real-life problem situations (Segalàs et al., 2010). Cases can be presented in the form of stories, models, descriptions, solutions or applications, and students can work individually or in groups (Hyppönen & Lindén, 2009). The students' task is: to diagnose the particular problem(s) only; to diagnose the problem(s) and provide solution(s); and to give reasons and implications of action after providing both problem and solution (Sajjad, 2010). By working on a case, students develop critical and innovative thinking, the ability to see problems from different angles and, in the case of group work, the ability to work in a group. Through discussion, students develop the ability to defend their own position, but also to adopt other students' constructive opinions (Cvetković et al., 2015).

## CONCLUSION

In recent years, education for sustainable development has been seen as a new educational paradigm in the transformation and transition of the world and the economy towards sustainability. In this regard, didactic and methodological issues and problems in this area are of special interest for research. Incorporating sustainable development into the educational system and process requires systemic thinking and interdisciplinary approaches. It also requires didactic and methodological approaches that are innovative, interactive, experimental and transformative. The review and the analysis of the selected literature sources indicate that there are plenty of methodological approaches and variants that the authors promote as desirable or innovative in education for sustainable development. The analysis and the systematization of these methodological approaches and methods indicate that the conceptualization of a special discipline in this field – the teaching methodology of education for sustainable development – is tentatively but surely emerging. Therefore, this paper opens up new research tasks when it comes to the further development of teaching methodology in the field of education for sustainable development, both at the level of the educational system as a whole and in its individual segments.

## REFERENCES

- Androutsos, A., & Brinia V. (2020). 'Developing an innovative pedagogy for sustainability in higher education'. In V. Brinia & J. P. Davim (Eds.), *Designing an innovative pedagogy for sustainable development in higher education*, Boca Raton, FL: CRC Press, pp. 119-131.
- Barth, M., Godemann, J. Rieckmann, M., & Stoltenberg, U. (2007). 'Developing key competencies for sustainable development', *International Journal of Sustainability in Higher Education*, 8, pp. 416-430.
- Basic Elements for the UNECE Strategy for Education for Sustainable Development, Statement of Education for Sustainable Development by the UNECE Ministers of the Environment, *UNECE 5<sup>th</sup> Ministerial Conference: Environment for Europe, Kiev, 21-23 May 2003*.
- Brundiers, K., & Wieck, A. (2013). 'Do we teach what we preach? an international comparison of problem- and project-based learning courses in sustainability', *Sustainability*, 5, pp. 1725-1746.
- Carpentier, C.L., & Braun, H. (2020). 'Agenda 2030 for Sustainable Development: A powerful global framework', *Journal of the International Council for Small Business*, 1(1), pp. 14-23.
- Cutting, R. (2016). 'Developing pedagogic approaches to encourage decision-making, invention, innovative thinking and problem-solving'. In D. Summers & R. Cutting (Eds.), *Education for sustainable development in further education: Embedding sustainability into teaching, learning and the curriculum*, London, UK: Palgrave Macmillan, pp. 263-277.
- Cvetković, M., Nastić-Stojanović, J. i Stojanović, M. (2015). *Priručnik o nastavnim metodama na poljoprivrednim studijama: Iskustva visokoškolskih institucija iz Srbije i Bosne i Hercegovine*, Banja Luka: Univerzitet u Banjoj Luci, Poljoprivredni fakultet.
- Felder, R.M., & Brent, R. (2009). 'Active learning: An introduction', *ASQ Higher Education Brief*, 2(4), [online], available at: [https://www.researchgate.net/publication/242102584\\_Active\\_learning\\_An\\_introduction](https://www.researchgate.net/publication/242102584_Active_learning_An_introduction) [Accessed 15 Aug 2022].
- Frisk, E., & Larson, K. (2011). 'Educating for sustainability: competencies & practices for transformative action', *Journal of Sustainability Education*, 2, [online], available at: [http://www.susted.com/wordpress/content/educating-for-sustainability-competencies-practices-for-transformative-action\\_2011\\_03/](http://www.susted.com/wordpress/content/educating-for-sustainability-competencies-practices-for-transformative-action_2011_03/) [Accessed 8 Aug 2022].
- García-González, E., Jiménez-Fontana, R., Azcárate Goded, P., & Cardeñoso, J. M. (2016). 'Inclusion of sustainability in university classrooms through methodology'. In W. Leal Filho, L. Brandli, P. Castro, & J. Newman (Eds.), *Handbook of theory and practice of sustainable development in higher education*, Cham, CH: Springer, pp. 3-19.
- Gollob, R., Krapf, P., Ólafsdóttir, Ó., & Weidinger, W. (2010). *Obrazovanjem do demokratije. Propratni materijal za nastavnike obrazovanja za demokratiju i ljudska prava*. Savet Evrope, [online], available: <https://www.living-democracy.com/me/textbooks/volume-1/> [Accessed 16 Aug 2022].
- Hyppönen, O. & Lindén, S. (2009). *Handbook for teachers - course structures, teaching methods and assessment*, Helsinki: University of Technology: Teaching and Learning Development Unit.
- Ledić, J. (2006). *Zašto ulagati vrijeme u aktivno učenje?*, Rijeka: Udruga za razvoj visokoga školstva „Universitas”.
- Lozano, R., Merrill, M.Y., Sammalisto, K., Ceulemans, K., & Lozano, F.J. (2017). 'Connecting competences and pedagogical approaches for sustainable development in higher education: A literature review and framework proposal', *Sustainability*, 9(10), 1889, [online], available at: <https://www.mdpi.com/2071-1050/9/10/1889/htm> [Accessed 16 Aug 2022].
- Mikanović, B. (2012). 'Inoviranje univerzitetske nastave u funkciji kvaliteta obrazovanja'. U B. Dimitrijević (ur.),

Obrazovanje i savremeni univerzitet: tematski zbornik radova, Niš: Filozofski fakultet, str. 44-57.

Nikolić, V. (2017). *Teorija i organizacija obrazovanja za zaštitu*, Niš: Fakultet zaštite na radu.

Peko, A., & Varga, R. (2014). 'Active learning in classrooms', *Život i škola*, 31(1), pp. 59-75.

Prince, M. (2004). 'Does active learning work? A review of the research', *Journal of Engineering Education*, 93(3), pp. 223-231.

Ristanović, D. (2019). *Projektni model nastave prirode i društva*, Jagodina: Fakultet pedagoških nauka Univerziteta u Kragujevcu. Pucmanović, Đ. (2019).

Rosenberg, E. (2009). *Teacher education workbook for environment and sustainability education*, Grahamstown: Rhodes University Environmental Education and Sustainability Unit.

Sajjad, S. (2010). 'Effective teaching methods at higher education level', *Pakistan Journal of Special Education*, [online], available at: <https://citeseerx.ist.psu.edu/viewdoc/summary?doi=10.1.1.68> [Accessed 13 Aug 2022].

Sarabhai, K.V. (2015). 'ESD for sustainable development goals (SDGs)', *Journal of Education for Sustainable Development*, 9(2), pp. 121-123.

Scoullou, M., & Malotidi, V. (2004). *Handbook on methods used in environmental education and education for sustainable development*, Athens: MIO-ESCDE.

Segalàs, J., Ferrer-Ballas, D., & Mulder K.F. (2010). 'What do engineering students learn in sustainability courses? The effect of the pedagogical approach', *Journal of Cleaner Production*, 18, pp. 275-284.

Simić, K. (2015). *Osnove metodike nastave*, Brčko, BiH: Evropski univerzitet Brčko distrikta.

Steinmann, A. (2003). 'Implementing sustainable development through problem-based learning: Pedagogy and practice', *Journal of Professional Issues in Engineering Education and Practice*, 129(4), pp. 216-224.

Svilengaćanin, G. i Bojić Perkin, A. (2020). *Škola za sbe ili obrazovanje za održivi razvoj*, Novi Bečej: Centar za učenje i kulturu – Plenum.

Šefer, J., Radišić, J. i Jošić, S. (2012). 'Istraživački rad i rešavanje problema kao podsticaj stvaralaštva, inicijative i saradnje u nastavi'. U J. Šefer i J. Radišić (ur.), *Stvaralaštvo, inicijativa i saradnja: implikacije za obrazovnu praksu, II deo*, Beograd: Institut za pedagoška istraživanja, str. 243-265.

Tilbury, D., & Cooke, K. (2005). *A national review of environmental education and its contribution to sustainability in Australia: Frameworks for sustainability*, Canberra: Australian Government Department of the Environment and Heritage and Australian Research Institute on Education for Sustainability.

UNESCO (2006). *Framework for the UNDES D Implementation Scheme*, Place de Fontenoy, Paris: UNESCO,

[online], available at: <https://unesdoc.unesco.org/ark:/48223/pf0000148650> [Accessed 10 Aug 2022].

UNESCO (2012). *Education for Sustainable Development Sourcebook*, Place de Fontenoy, Paris: UNESCO, [online], available at: <https://sustainabledevelopment.un.org/index.php?page=view&type=400&nr=926&menu=1515> [Accessed 10 Aug 2022].

UNESCO (2017). *Education for Sustainable Development: Learning Objectives*. Place de Fontenoy, Paris: UNESCO, [online], available at: <https://unesdoc.unesco.org/ark:/48223/pf0000247444> [Accessed 10 Aug 2022].

Vrbaneć, B., Garašić, D. i Pašalić, A. (prir.). (2011). *Obrazovanje za održivi razvoj. Priručnik za osnovne i srednje škole*, Zagreb: Agencija za odgoj i obrazovanje.

Wals, A.E. & Lenglet, F. (2016). 'Sustainability citizens'. In: R. Horne, J. Fien, B.B. Beza, & A. Nelson (Eds.), *Sustainability citizenship in cities: Theory and practice*, Routledge, pp. 52-66.

WCED (1987). *Our Common Future*, [online], available at: <https://sustainabledevelopment.un.org/content/documents/5987our-common-future.pdf> [Accessed 7 Aug 2022].

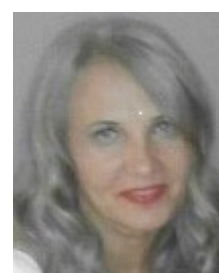
*What are classroom experiments?* (n.d.), [online], available at: <https://serc.carleton.edu/econ/experiments/what.html> [Accessed 16 Aug 2022].

## ACKNOWLEDGEMENTS

This research was published with the support of the Ministry of Education, Science and Technological Development of the Republic of Serbia, following the Agreement on Realization and Financing of Scientific Research of the Scientific Research Organization in 2022, Agreement Registration Number 451-03-68/2022-14 /200148.

## BIOGRAPHY of the first author

**Vesna Nikolić** is a full professor at the Faculty of Occupational Safety in Niš, Republic of Serbia. She is the author or co-author of several monographs, textbooks and over 350 scientific papers published in scientific journals and proceedings of scientific conferences.



Her research interests include: education, training and learning, human resources management and development, knowledge management, organizational learning and behaviour (particularly in the system of safety, sustainable development, emergency and disaster management), etc.

STANKO STANKOV<sup>1</sup>

<sup>1</sup>University of Niš,  
Faculty of Electronic Engineering

<sup>1</sup>stanko.stankov@elfak.ni.ac.rs

## SECURITY AND PROTECTION OF SUPERVISORY CONTROL SYSTEMS IN LIGHT OF INDUSTRY 4.0

**Abstract:** *Supervisory and control systems are a set of hardware and software that enable local or remote control of process variables and parameters of automated technological processes in a number of industries. These are SCADA platforms (Supervisory Control and Data Acquisition), which provide complex monitoring, acquisition and processing of real-time data, changes registration, alarm generation and creation of reports on events in the process. SCADA systems can directly communicate with each other in the field of automation elements such as sensors, flaps, switching elements, pumps, motors, solenoid and pneumatic valves, pneumatic and hydraulic systems, etc. via the Human Machine Interface (HMI). SCADA systems are applied in all spheres of engineering and technology because they can offer solutions to relatively simple problems and requirements for the control of giant complex systems with equipment and devices installed over hundreds or thousands of square kilometres. Breakdowns and accidents in physical devices and hardware infrastructure often lead to the irreversible loss of critical data. In the age of Industry 4.0, protection is provided by storing data in cloud servers and access to data is achieved at any time and from any place after the necessary user identification. The summary of last-minute process events, including reports on production speed, machine and equipment efficiency, production cycle duration, etc., can be visualized on any mobile device and is accessible from anywhere using the appropriate application. The security of these systems is crucial in important strategic economic systems and facilities, such as the electricity sector, petrochemical industry, water supply systems, gas pipelines, oil pipelines, production plants, and communication and transport infrastructure. The permanent growth and increase in the number of SCADA systems that control the mentioned objects and processes engenders various excessive situations in the operation of controlled objects. Many firewalls, as a precautionary way, include Intrusion Prevention Systems (IPS), which can detect hacker attacks on SCADA systems. However, firewalls alone cannot protect against all types of attacks. A multi-layered strategy is needed that includes at least two overlapping security mechanisms.*

**Key words:** control system, SCADA, protection, firewall

### INTRODUCTION

Today, process computers – programmable logic controllers (PLCs) – are indispensable elements in automatic regulation systems, whether they are simpler processes and requirements when using controllers with more modest capabilities or complex technological processes with strict requirements, whereby high-performance controllers that can solve extremely complex problems with the implementation of appropriate control laws are applied. The features of PLCs are characterized by exceptional reliability, functionality, flexibility, compactness, high speed,

robustness in terms of supply voltage, ambient conditions and manipulation, protection against interference in very unfavourable conditions of the industrial environment, developed communication protocols resistant to interference that occur in the operation of heavy and industrial plants, rapid development of applications, and diagnosis of malfunctions and errors.

In high-risk plants, the application of redundant (duplex) systems eliminates the risk of control logic failure (Stankov, 2018). These systems can be expanded both in terms of hardware and software



according to the needs of the user. They are user friendly, with an emphasis on intuitiveness, which fully meets modern requirements: quick change of management function without changing the hardware of the management system by relatively simple changes to the executable program or its complete replacement. Complete visualization of the process has always been the aspiration of both control system designers and direct users.

Control and data acquisition systems, as a machine-human interface, have captivated both application designers and users with exceptional possibilities of visual representation of management objects and process animation, with effects that contribute to easier monitoring, better understanding, and understanding of technological processes. This computerized monitoring and control system combines data acquisition systems with data transfer systems and graphics software to provide real-time monitoring and control of a specific process from a single centre. The monitoring system is a relatively complex task, especially if it is a complex plant with a large number of different measurement-acquisition and control devices that need to be connected into a functional unit.

At the same time, SCADA software is required, on the one hand, to enable simple specification of functional units of the system and individual elements within them, as well as an optimal operator interface, and on the other hand, to provide an intuitive graphic environment, process animation, real-time and chronological monitoring of relevant quantities, generation of alarms, acquisition and storage of data, analysis of that data, formation of shift, and daily and periodical reports. The implementation of supervision and control of the process ensures (Stankov, 2013, Stankov, 2018; Stankov, 2021)

- visualization of the drive status and measurement of essential process values and parameters in the plant;
- reception, processing and display of process measurements; trend in the form of tables and/or graphs; chronology of events and analysis;
- monitoring and processing of warning and alarm signals; generation and presentation of reports;
- additional functions at the user's request.

At the beginning of their development, the security of supervisory control systems was mainly conditioned by physical attacks. Namely, it was considered that the isolation of the control desk, which could only be accessed by authorized personnel, was sufficient protection for the SCADA system. There was practically a very low level of attack risk, since a small number of users had the necessary technical knowledge about the system, and the data transmission paths were isolated. However, the intensive and dynamic development of hardware and software during the 1970s, which until then were independent entities, and the emergence of modern systems associated with

standard personal computers and operating systems, TCP/IP communication protocols, and the use of the Internet as a transmission medium, led to numerous security and reliability issues in data transmission. With the Internet as a transmission medium, phenomena emerged that caused security and reliability problems in data transmission.

The application of TCP/IP and web technologies have provided hackers with alternative routes to control and monitoring systems. One of the reasons for the vulnerability of these systems is their connection to the corporate network.

With the Internet as a transmission medium, there have been phenomena that caused security and reliability problems in data transmission. The application of TCP/IP and web technologies has provided hackers with alternative routes to control and monitoring systems. One of the reasons for the vulnerability of these systems is their connection to the corporate network (Stankov, 2018; Stankov, 2021; Shinder, 2011; Stankov and Ičić, 2010).

## **CHARACTERISTICS OF MODERN SCADA SYSTEMS**

The first SCADA platforms appeared at the time of mainframe computers, when there were still no network architectures and when control and monitoring systems functioned independently. During the 1980s and 1990s, SCADA technology continued to evolve thanks to compact computer systems, original LAN networks, and PC-based HMI software. At the end of the 1990s and in the first decade of the 21<sup>st</sup> century, SCADA systems took a serious turn by adopting an open system architecture and universal communication protocols. This generation of SCADA systems reaps the benefits of these protocols, such as Ethernet, which enables connection to a much larger number of automation elements in the field. And while SCADA systems are experiencing rapid development, a significant portion of industrial enterprises continue to explore problems related to access to more industrial data at the enterprise level. The technological boom that occurred around the turn of the new century accelerated the development of PCs and IT systems. At the same time, SQL (structured query language) databases became a standard in IT architecture, but were not accepted by the creators of SCADA solutions. This led to a divergence between control technologies, IT systems and SCADA platforms, which predetermined the fate of SCADA solutions – to remain at one level for a relatively long period of time (Stankov, 2013; Stankov, 2021). The hierarchical structure of the SCADA system has four levels with clearly defined functions: equipment in the field; programmable controllers or Remote Terminal Units (RTUs); communication networks; and SCADA software. PLCs and RTUs are computer devices (microcomputers) that collect data from many objects, e.g. process equipment, HMI

(human machine interface), sensors and other devices, and direct these inputs to the computers on which SCADA software is installed. This software platform is used to distribute and visualize the necessary data, which is of great help to process operators. SCADA accepts data from remote elements of automation in the field (electromagnetic and electromotive valves, electropneumatic devices, pumps, electric drives, various sensors of process variables, etc.). SCADA also provides local management of processes, by turning on/off elements in the field at appropriate time intervals, complementing the strategy of remote control, data acquisition and registration of various events (e.g. reaching critical values of process variables). Modern SCADA platforms have graphical interfaces, options for setting alarm conditions and sending reports to users, and complex options for storing, processing and analyzing data in real time. Modern SCADA systems provide access to relevant data that is required for the operation of process equipment in real time. At the same time, they provide the possibility for rapid development of applications, where in-depth knowledge of the sphere of software design is not necessary. The application of modern IT standards and technologies such as SQL and web-based applications in SCADA software optimizes the efficiency, security, productivity and reliability of the SCADA system. Software platforms that use SQL databases provide users with a number of advantages and benefits compared to conventional SCADA systems, including simple integration into the existing MES (manufacturing execution system) and ERP (Enterprise Resource Planning) systems for production implementation. In the previously described stages of SCADA system development, modern knowledge was implemented at the time. The first systems were characterized by the use of microcomputers. In the second phase of development, distributed control techniques were applied and in the third phase there was an exponential development of the global network and Internet applications. The fourth stage in the development of SCADA systems, which is ongoing, is influenced by the IoT (Internet of Things), IIoT (Industrial Internet of Things), Industry 4.0 and smart industry (Stankov, 2013; Stankov, 2021; Stankov, 2022). These are the main technological tendencies characteristic of the development of the fourth industrial revolution and its transition from a digitized production platform to cyber-physical systems. While in the third industrial revolution the emphasis was on automation, with CNC, SCADA, ERP and MES systems being the main technological innovations, Industry 4.0 is characterized by innovative production concepts based on connected, integrated, modular, cloud, and smart technologies. Cloud computing is at the core of the technological evolution of the latest SCADA systems. The emergence of combined and hybrid SCADA/MES systems that are intended for automation at the enterprise level is one of the most significant advances in the development of modern

production processes, with a special emphasis on data management. In modern industry, the volume of data is increasing, which requires further development and improvement of the SCADA system. SCADA/MES hybrid systems will continue to play an important role in real-time operational management in the smart factories of the future through data acquisition, storage and management, supported by the latest developments in IT and automation. Traditional cloud architectures will gradually evolve thanks to edge computing – a method for optimizing cloud computing systems through data processing at the end of the network, close to the source of information. This will result in a smaller amount of data being stored in the cloud server and a reduction in network latency, which will lead to a reduction in the response time of control and monitoring systems in critical applications. Acceptance of the edge computing strategy will enable a more extensive use of innovative communication standards such as LTE (Long-Term Evolution) and LoRA (Long Range Radio Module), which enable immediate access to data from any point in the world (Stankov, 2018; Stankov, 2022). One of the drivers of the evolution of modern SCADA systems is the growing need for mutual cooperation of information and operational technologies. Merging and integration of SCADA and MES platforms as one hybrid solution highlights the necessity of defining and strictly dividing responsibilities between process and information technologies. Hybridization will determine a new understanding of the concept of real-time and near-real-time systems. The key advantage of systems that rely on cloud infrastructure is the possibility of using mechanisms by which data analysis is performed, which is crucial for IoT technologies and smart production. Basic analytical functions can be implemented in sensors, and smart functionality in the final elements of automation, which would enable the selection of data on critical values of process variables and parameters, from the multitude of data coming into the SCADA system. Algorithms for machine learning and platforms for the analysis of a large amount of data (big data) can be applied directly in the cloud infrastructure, whereby the system ‘learns’ to produce solutions automatically without human intervention, based on appropriate models and a large database. This functionality increases the level of process automation with the possibility of predictive maintenance (Stankov, 2022). A significant advantage of modern SCADA platforms is reflected in cost reduction and increased resource security. Reducing the costs related to the lease and maintenance of hardware affects the budget planning and implementation of the SCADA system based on the cloud infrastructure, which enables comprehensive analysis and predictive maintenance, which in turn reduces the risk of sudden failure of the operating system and equipment. Failures related to physical devices and hardware infrastructure often result in the irreversible loss of important data. The storage of this data in cloud servers ensures the

protection of this data, and access to it is enabled at any time and from any place after the appropriate identification of the user (Stankov, 2013; Stankov, 2018).

## DESIGN AND IMPLEMENTATION OF A SUPERVISORY CONTROL SYSTEM

The development and implementation of a management system for a specific process takes place in several steps (Stankov, 2013; Stankov, 2018):

- Conceptualizing the conceptual solution of the management system according to the specifics of the process;
- Hardware configuration planning (equipment selection according to the conceptual solution of the management system) and project development;
- Installation of devices and equipment in distribution cabinets; creation of management software (program for PLC on the basis of which the process is managed);
- Creation of monitoring software (visualization of the managed process and software support for operators);
- Putting the management-supervisory system into operation; creation of work instructions intended for maintenance services and operators.

The criteria for choosing a management system are as follows:

- Complexity of the process being managed. In connection with this, configuration planning is carried out: processor power, memory capacity, number of discrete inputs and outputs, number of analogue inputs and outputs, as well as outputs with pulse width modulation, number of timers, counters, internal bits, real time clock;
- Data processing speed (cycle time and program length);
- Modularity and the ability to expand the architecture, the ability to connect to a network and remote control;
- Reliability in an industrial environment, interruption of processing according to a certain procedure in real time, protection against interference, protection against incompetent operator actions, protection of inputs and outputs, visualization of input and output states, data archiving, organization of a 'watch dog' for time monitoring cycles and certain operations;
- Complexity of data processing, repertoire of commands and functional blocks, floating point arithmetic, processing of analogue quantities – filtering, linearization and approximation, PID controllers, fuzzy logic, non-linear functions, etc.;
- Simple system commissioning and maintenance;
- Configuration cost, availability, time required for implementation and training. For the sake of

illustration, an example of the control and monitoring system of the Mediana 2 water facility in Niš is given. The block diagram of the Mediana 2 water supply system is shown in Figure 1 (Stankov, 2013). The automatic control system of the Mediana 2 water plant is based on PLCs and operator panels, which are the interfaces between the operator and the plant. The control system is also connected to the SCADA computer in the dispatch centre (DC). The facility's normal operating mode is automatic. For special purposes, individual technical units can be switched to manual control mode, which is suitable for testing equipment during overhauls and maintenance.

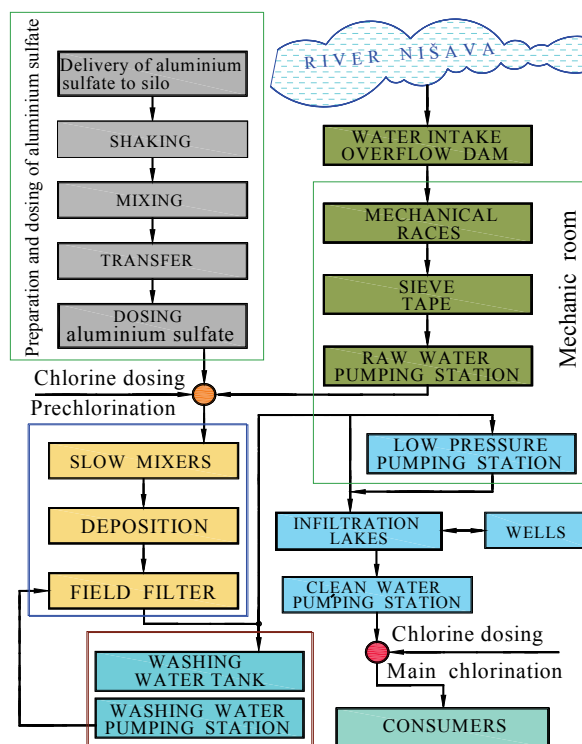


Figure 1. Organization of the Mediana 2 water supply system

The basis of the management of the Mediana 2 water supply system is the central monitoring and control system installed in the DC. The factory management block diagram is shown in Figure 2 (Stankov, 2013). The system architecture is based on a master-slave configuration made up of PLC controllers: Simatic S7-400 (redundant pair) as the master PLC; S7-300 (plant for preparation and dosing of Al sulphate, pumping station (PS) for raw water, sedimentation tanks and filter fields, PS for washing the filter plant, PS for clean water); S7 1200 (transformer station, diesel generator, constitution, mechanical water purification system – mechanical rakes and sieves; compressor station, chlorine station). Each local controller is connected to the KTP operator panel using the PROFINET communication protocol. The master controller is connected to the slave controllers and servers via the

ETHERNET network. A real-time database server has been installed in the DC, which distributes data to workstations – clients (DC, maintenance service, chemical laboratory, management) (Stankov, 2018). SCADA is organized in the form of menus and sub-menus, whereby the functionality of the system is displayed with certain animations (e.g. the operation of pumps, electric valves), the change of a quantity is displayed in real time in the form of a trend graph or in digital form (level values, flow, turbidity, residual chlorine, etc.), while reaching of the limit values is signalled as an alarm message with sound and light signalling.

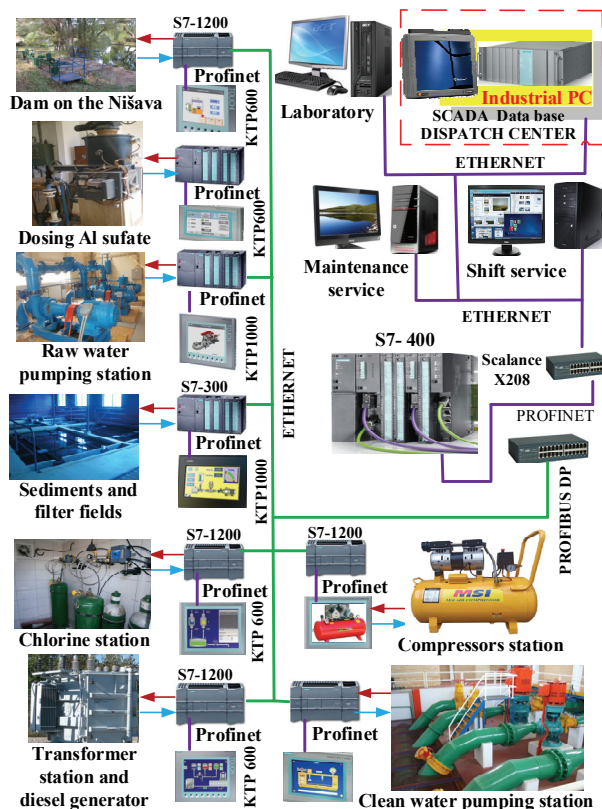


Figure 2. Block diagram of supervisory control

The main tasks set before the SCADA system are

- collection of real-time digital and analogue data from all objects connected to the system (a large number of tags);
- archiving of relevant information obtained on the basis of collected data in a relational database;
- presentation of real-time and archived data through synoptic screens, trends, graphs and tables;
- real-time management and monitoring of water intake, mechanical water purification, chemical preparation, well facilities, pumping stations. The master redundant tandem system of S7-400 PLCs in conjunction with the SCADA computer in the DC dictates communication with all remote stations, sends queries, and commands, accepts and archives all messages arriving from controlled objects.

## MEASURES FOR SAFE OPERATION OF PLC CONFIGURATION

High temperatures, humidity, electromagnetic radiation, dust, vibrations, etc., as well as the influence of aggressive chemical factors, require certain measures to protect the PLC (e.g. forced ventilation, installation of a regulated heater in the cabinet, etc.). The main sources of disturbances in plants are the appearance of thermoelectromotive force, the appearance of static electricity, the proximity of transformer stations, welding machines, etc. Interference is eliminated by installing separating transformers for the supply voltage and using optocouplers for direct signals. The reliability of PLC operation is ensured by using a special 'watch dog' timer, which measures the duration of each cycle. At the beginning of the cycle, the central processing unit (CPU) is tested. In case of irregularity during the execution of the program, the timer causes an interruption. The influence of physical and mechanical factors (extremely low or, for example, when exceeding or dividing by zero). The reliability of the data is ensured by using protection codes and checking the parity bit (address). The value of the supply voltage is constantly monitored, and approaching the defined limit causes a priority interruption in order to protect data. Most PLCs are allowed to automatically initialize or resume operation from the point of interruption, after establishing the correct supply voltage. It is known that 80% of failures in PLC systems occur due to irregularities related to inputs and outputs. Accordingly, certain activities are undertaken: measuring the input signals a greater number of times, comparing the command signal with the response, etc. (Berger, 2012; Stankov, 2013; Stankov, 2018).

## RELIABILITY AND SECURITY OF THE SCADA SYSTEM

Large companies, such as petrochemical and gas companies, water systems, power systems, etc., include large areas in which they operate (often thousands of square kilometres of land and sea). Connecting managed facilities in those areas is a major challenge. Essential data is collected and transmitted from remote locations where physical protection is low and maintenance is extremely expensive. On the one hand, there is a need for safe and reliable data transmission, and on the other hand, due to the vast areas that need to be covered, companies often use intermediary networks for the transmission of important process data. If the most modern mechanisms for data encryption and identification are not used, the data transmission itself is unreliable and insecure (Stankov and Ičić, 2010; Stankov, 2021). The consequence of these tendencies is an increase in the number of persons who possess sensitive knowledge. This knowledge allows them to break into control systems that are vulnerable to attacks. Weak points of IT operating systems are also

characteristic of SCADA systems. However, revitalizing IT software is simpler than maintaining and renewing SCADA software, which needs to function flawlessly and without interruption. Easily accessible information about the technical infrastructure and management-monitoring systems facilitates access to potential hackers. Often, various technical project documents, standards and regulations for sensitive infrastructures and technical-technological systems can be found on the Internet, which seriously undermines the security of the mentioned systems. One of the problems of the SCADA system is caused by the use of antivirus programs for intrusion detection (Intrusion Detection Software-IDS). Many experts in this field believe that firewalls and antivirus programs do not provide satisfactory protection. Wireless communications that are increasingly in use are also a potential threat to the security of SCADA systems (Pietro and Mancini, 2008; Berger, 2012). Devices that use multiple network interfaces to connect to each other, usually different networks and protocols, can somehow allow unauthorized access and transfer of data from one network to another. Certain process computers (PLCs) installed as remote-control systems can recognize potential points of uncertainty in the transmission chain. However, the mathematical capabilities and memory capacities of these processors are usually insufficient to improve security. In addition, after the installation of these computers, they are not changed for ten or more years, which increases the vulnerability of the control and monitoring system year after year (Stankov and Ičić, 2010). A problem in the SCADA system may be caused by a disgruntled operator, who is somehow motivated to disrupt the functionality of the system or even damage the hardware. The possibility that the operator himself, due to carelessness, made errors that would lead to SCADA damage is also not excluded. Viruses pose a special problem for the functionality of the control and monitoring system. The most infamous computer viruses include worms, which destroy or compromise data, malware viruses that are designed and programmed for specific actions, and even ad-ware viruses that are merely irritating – they constantly show advertisements. Practically all types of computer viruses are capable of stealing user data, passwords, documents from hard drives, memory cards, as well as online data storage (cloud storage). Many applications and programs have ‘bugs’ in their code, which allow data theft or computer and device damage even without any viruses or malware (Barker, 2021). The operating systems themselves contain a large number of bugs, which are publicly known, and hackers exploit them until the software manufacturer patches them with a suitable upgrade of its software. The Stuxnet virus was discovered in 2012 and is closely related to the Duqu and Flame malware. Duqu asks for information (e.g. access codes to the control-monitoring system) that it uses to break into industrial networks and communication protocols. Flame was in operation for

several years before it was discovered, and it is capable of intruding on Bluetooth communications. Auto CAD files are also interesting for Duqu and Flame. There are a number of well-studied publications on the Stuxnet, Duqu, and Flame worms. There is a known case of the Stuxnet malware that attacked the Industrial Safety Systems (ICS) used in Iran’s uranium enrichment program. The famous Dragonfly cyber espionage group is also known for ICS attacks. Using a Trojan, they compromised the software of a number of ICS equipment providers. Another well-known virus is the Gauss virus, discovered in 2012, which sends bank account codes of different users to hackers. It also transfers cookie files about the details of the infected system, and also attacks USB memory. In certain situations, this virus destroys itself along with the stolen data. Not long ago, the appearance of Triton created big problems for management and control systems. Triton is a very dangerous and atypical computer virus. Triton software is called Tritonex by the US agencies NSA (US National Security Agency) and CISA (US Critical Infrastructure Security Agency). This software can remain undetected on computers for years and it specifically attacks SCADA systems. A well-known incident occurred in 2017, when the computer systems that managed one of the refineries in Saudi Arabia stopped working, permanently damaging the oil flow meters and thus disabling the process management in the refinery. The safety valves were also put out of operation. This had never happened before and the event caused great concern in the petrochemical industry, as well as among intelligence agencies. At first, no one assumed that it was an organized attack using a new virus. The virus infiltrated computers that used Triconex technology for similar installations. Symantec, which deals with security issues of SCADA systems, named this software ‘Triton’ (after the god of the sea who could move invisibly across all seas). It is suspected that some hacker groups, such as TEMP, Isotope and Trickbot obtained the Triton code itself, adapted it and used it under the name ‘TsNIKhM’. Triton is the first recorded case of malware attacking SIS devices. However, this is not the first attack on ICS. In 2021, the computer network of the airport in San Francisco was hacked, and their websites, through which flights were scheduled and ticket payments processed, were taken down (Monnappa, 2018). The connection between the SCADA system and the corporate network is a major risk for the security of the control and monitoring system. This connection must be carefully designed and executed. It is desirable to have as few connections between networks as possible (if possible, only one connection) when using firewalls. The firewalls protect network devices by constantly monitoring and controlling data packets. The protection involves monitoring and controlling whether the received data packets correspond to the previously selected filtering strategy. There are several types of firewalls: packet filtering firewalls, stateful inspection firewalls,



application-proxy gateway firewalls, and others (Eastom, 2022; Brooks, Grow and Craig, 2018). Firewalls are sets of software mechanisms that enable the implementation of safety and security techniques. They block all data traffic (except that with special permissions) between an unprotected corporate LAN (local area network) and a protected ICS (Internet Connection Sharing) network. Thanks to firewalls, restrictions can be placed on users in the sense that they can only connect to certain devices over the network, which reduces the possibility of intentional or accidental unauthorized access to the control device. Combined and hybrid SCADA/MES systems intended for enterprise automation are a step forward in the development of production processes. In recent times, systems based on cloud infrastructure with analytical instruments, which are very important in the era of IoT technology, are being increasingly applied. In industrial platforms, data analysis is of crucial importance for the implementation of intelligent production standards (Stankov, 2018; Stankov, 2022). As an integral part of an industrial complex, SCADA systems contribute to its operational efficiency through intelligent management of process technology and improved communication between equipment in the field and control systems in the era of Industry 4.0 and IoT technologies.

## CONCLUSION

This paper presented modern trends in the development of control and monitoring systems (SCADA systems) in the light of Industry 4.0 and challenges related to their security. Along with the development of control-supervisory systems, the need to protect data that is accepted, processed and transmitted also arose. With the permanent growth of SCADA, the number of various excess situations in the operation of objects of control also increases. Many firewalls include Intrusion Prevention Systems (IPS) techniques that can detect hacker attacks on SCADA systems. However, firewalls alone cannot protect a system from all types of attacks, which is why a multi-layered strategy containing at least two security mechanisms that cover each other is necessary.

## REFERENCES

- Barker, D. (2021). *Malware Analysis Techniques: Tricks for the triage of Adversarial Software*, UK Birmingham.
- Berger, H. (2012). *Automating with STEP 7 in STL and SCL Programmable controllers SIMATIC S7 - 300/400*, 6<sup>th</sup> revised and enlarged edition, Enralgen.
- Brooksand, J. C., Eastom, C. (2022). *Computer Security Fundamentals*, fourth edition, USA Indianapolis.
- Grow, C., Craig, A. P. (2018). *Cybersecurity Essentials*, USA Indianapolis.

Monnappa K. A., (2018). *Learning Malware Analysis*, UK Birmingham.

Pietro, D. R., Mancini, L. V. (2008). *Intrusion Detection Systems, Advances in Information Security*, Springer.

Shinder, W. T. (2011). *Best Damn Firewall Book Period*, 2nd Edition, Publisher: Syngress.

Stankov, S., Ičić, Z. (2010). Transfer of data in the systems for monitoring and control of thermal plants, *41 International HVAC&R Congress and Exhibition, Proceedings*. pp, 269 - 279, (in Serbian)

Stankov, S. (2011). Control of Pumping Stations in Water Supply Systems, *Journal Voda i sanitarna tehnika*, vol. XLI, No. 3-4, pp. 47-54.

Stankov, S. (2013). *The main project of the reconstruction of the power supply and automatic control of the Water Factory "Mediana 2"* in Niš. (in Serbian)

Stankov, S. (2013). Modern Control of Mineral Wool Production Process, *Journal Hemijska industrija*, vol. 67, No 2, 2013, pp. 375 – 384. (in Serbian)

Stankov, S. (2018). Control and Supervision of Water Purification Plant, *Journal 'Vodoprivreda'*, no 4-6, vol. 50, pp. 319-332. (in Serbian)

Stankov, S. (2018). A Supervisory Control System of a Biodiesel Production Plant, *Journal Hemijska industrija*, vol. 72, No 6, pp. 315-328, (in Serbian)

Stankov, S. (2021). Automation and Industry 4.0, *Journal Acta Technica Corvinensis – Bulletin of Engineering*, Tome XIV, Fascicule 2 [April-June], pp. 59-63.

Stankov, S. (2022). Big Data in Water Supply and Sewerage System, *Journal Acta Technica Corvinensis – Bulletin of Engineering*, Tome XIV, Fascicule 2 [January-March], pp. 21-25.

## ACKNOWLEDGEMENTS

The paper was supported by the Serbian Ministry of Education, Science and Technological Development (project TR 35005).

## BIOGRAPHY of the first author

**Stanko P. Stankov**, M.Sc., is currently employed at the Faculty of Electronic Engineering in Niš. Previously, he had been working in the industry sector for 20 years. He is the author/co-author of over 110 scientific and professional papers and 10 technical solutions.



Stankov is the responsible designer for more than 60 major projects implemented in the economic sector and the responsible contractor for the construction of a large number of industrial facilities and facilities for various purposes. He participated in two national projects (from 2011 onward).



CARLO CAIAZZO<sup>1</sup>  
ALEKSANDAR ĐORĐEVIĆ<sup>2</sup>  
MARIJA SAVKOVIĆ<sup>3</sup>  
MARKO ĐAPAN<sup>4</sup>  
ARSO VUKIĆEVIĆ<sup>5</sup>

<sup>1,2,3,4,5</sup> University of Kragujevac,  
Faculty of Engineering

<sup>1</sup>carlocaiazzo@fink.rs

<sup>2</sup>adjordjevic@kg.ac.rs

<sup>3</sup>marija.savkovic@kg.ac.rs

<sup>4</sup>djapan@kg.ac.rs

<sup>5</sup>arso\_kg@yahoo.com

## ARCHITECTURE OF HUMAN-ROBOT COLLABORATION IN MANUFACTURING INDUSTRIES

**Abstract:** *The fourth industrial revolution (I4.0) implies more collaborative and connected manufacturing. Industry 4.0 and smart manufacturing integrate human and intelligent devices to enhance workplace safety in a collaborative industrial environment (Safety 4.0). Collaborative robots (or cobots) have been developed with intuitive interfaces that support human operators in the physical workload of manufacturing tasks, such as handling hazardous materials or executing repetitive and monotonous actions with high reliability, such as assembly activities. However, the deployment of cobots must include application safety criteria to be taken into account in order to improve their interaction with operators. In this way, Human-robot collaboration (HRC) is being adopted in the smart manufacturing industry as a solution that mixes, within a shared workspace, the dexterity and cognitive faculties of human operators and the accuracy and repeatability skills of robots, guaranteeing no-danger conditions and absence of collision during this type of collaboration. The aim of this paper is to propose human-robot collaboration architecture and show how it will be possible to improve workers' safety through the implementation of the proposed architecture. Intelligent devices are integrated into human-robot workstations in order to protect the operator from hazards, injuries and occupational diseases. The proposed paper highlights safety guidelines regarding HRC and their application using smart equipment, such as sensors, computer vision systems, and so on. Overall, interaction with different degrees of collaboration and technologies increases not only the flexibility but also the complexity of the system. Therefore, this paper also focuses on identifying the main safety requirements in human-robot collaborative systems design*

**Key words:** architecture of human-robot collaboration, collaborative robot, human-robot collaboration, Industry 4.0, Safety 4.0, Occupational safety and health

## INTRODUCTION

Due to increasing competition in the global market and in order to respond to changes in customer requirements, organizations tend to introduce self-configurable and smart solutions in assembly production processes to ensure more efficient and ergonomic performance of work activities. Advanced digitalization has led to the fourth industrial revolution (or I4.0), where physical production is connected with smart digital technology. Its goal is to allow manufacturers to meet the ever-changing demand more efficiently and improve production processes using contemporary advanced technologies. Industry 4.0 denotes an approach to enabling the next generation of manufacturing (Hermann et al., 2016) and advocates the increased use of sensors, information and communication technologies, and advanced automation throughout factory facilities, promising shorter

development times, increased customization, greater flexibility, and improved resource efficiency (Kadir et al., 2018). Moreover, I4.0 will bring new paradigm shifts, which will have a positive impact on the management of occupational health and safety (OHS).

Automation and the application of collaborative robots contribute to enhanced efficiency and reliability of many assembly tasks that were previously performed manually by humans. On the other hand, the introduction of innovative technologies complicates manufacturing systems and increases the need for safety requirements (Tan et al., 2019).

Although traditional industrial robots were designed for performing highly repetitive and difficult tasks, their accuracy was low and they were not easy to program. Moreover, in complex assembly systems, their deployment might be a hazard for the operator and the other entities.

Collaborative robots (cobots) are designed to work, interact, and collaborate with humans (Kadir et al., 2018) in a common workspace. In this regard, their deployment is also changing the role played by humans in the workplace (Cherubini et al., 2016). In hybrid assembly systems, the robot holds the part for the worker who can adjust its position and mount it.

The main difference between cobots and traditional industrial robots is that cobots are designed to allow physical interaction with the operator in hybrid and fenceless work cells without the necessity of isolating the robot workspace. During Human-Robot Collaboration (HRC) within a shared workspace, the dexterity and cognitive faculties of human operators and the accuracy and repeatability skills of robots are combined, guaranteeing no-danger conditions.

On the other hand, the deployment of cobots requires safety criteria to be taken into account in order to improve their interaction with operators respecting the fact that interaction with different degrees of collaboration and technologies increases not only the flexibility but also the complexity of the system. The aim of this paper is to propose a human-robot architecture based on which workers' safety and health will be improved. The architecture involves a collaborative robot, a Poka-Yoke system, an audio 5.0 system, an EEG device, and a touch-screen PC and industrial computer. The paper also focuses on identifying the main safety requirements in human-robot collaborative systems design.

## **HUMAN-ROBOT COLLABORATION**

The application of advanced technologies (sensors, actuators, cameras, computer vision systems, etc.) enables the automation of the production process and delivery of the final product with minimal human intervention. It is especially important to apply automation in production processes that are not ergonomically suitable for humans, where workers are highly exposed to harmful and dangerous substances and where exceptional precision, which humans are not capable of achieving, is necessary. These technologies are applied to conduct real-time information collection, processing, and feedback control of the monitoring of workers' posture, health status, etc.

In I4.0, cyber-physical systems (CPSs) represent networks composed of physical objects and resources. This interconnectivity enables entities to communicate and cooperate with their environment and make decisions independently in the intelligent production process (Weiss et al., 2021).

In CPS, a collaborative robot (or cobot) is an important actor. Cobots are a particular kind of industrial robots, which are able to physically and safely interact with humans in a shared and fenceless workspace. Cobots help operators with non-ergonomic, repetitive, uncomfortable and dangerous operations. The main

features that distinguish a cobot from a traditional factory robot include improved safety features for working near the operator and simplified programming to allow for flexible application, enabling simple deployment and redeployment within a factory (Faccio et al., 2019).

In particular, HRC is the most advanced application of Human-Robot Interaction (HRI) in industrial settings, since it involves a simultaneous sharing of tasks and workspaces between the operator and the robot's system (Gualtieri et al., 2022).

Human-robot cooperation has been the focus of a large number of scientific papers in recent years (Matheson et al., 2019). HRC implies cooperation between a purposely designed robot system and an operator within a collaborative workspace (ISO, 2011a). These hybrid systems have to be selected and implemented depending on the task goal and the level of interaction (Weiss et al., 2021). Collaborative industrial robots perform tasks in collaboration with workers during production operations in a collaborative workspace (IFR, 2020; ISO 2016). Furthermore, they support workers with both physical and cognitive tasks. For example, a collaborative robot and an operator jointly perform assembly activities in such a way that the robot moves its hand into a specified position and orientation and then waits until the human places the object between the fingers of the gripper. When the robot detects that an object has been placed in its hand, it attempts to grasp the object. The same case has been applied previously for handing over an object from a robot to a human or during the performance of an assembling task (Edsinger and Kemp, 2007). The human operator mainly monitors the tasks and the operator's presence in the tasks, which is not continuous. The robots are designed in such a way that, unlike humans, they can work continuously without interruption and produce high-quality parts, while humans become tired after a certain time.

In an HRC environment, the abilities of the human and the robot are combined and integrated (Gervasi et al., 2020). Hence, the introduction of robots has a role to increase the efficiency and productivity of the production process. On the other hand, the role of human workers is mostly to compensate for the technological limitations and act as decision-makers for improved production planning and control with the support of these advanced systems (Nelles et al., 2016).

The interaction between humans and robots is achieved via voice command, gesture recognition, etc. Also, direct collaboration between the human and the robot can be achieved by using force control (Vysocky and Novak, 2016). Using EEG signals to connect a human with a collaborative robot and controlling humanoid robots using human EEG signals was the focus of a numerous research papers in the previous period (Wang and Chang, 2020, Weiss et al., 2021). Some research papers (Kriger and Surdilovic, 2008; Yu, 2019) point

out the possibility of using EEG signals to guide a robot in a collaborative environment. Communicating with a robot through EEG signals provides many benefits: the possibility to control a robot and execute collaborative activities and present a supporting communication with the robot in addition to other channels, such as voice, gesture, etc.

The main goal of HRC is to improve workplace safety and ergonomics, productivity, flexibility and effectiveness. Many manufacturers are eager to adopt HRC technology to enhance the effectiveness and flexibility of their production. The human operator is able to operate variant productions while the workability can be restricted by ergonomic factors and hence influence the accuracy and production volume (KUKA, 2016).

A research study on HRC has presented a human-centric design (HCD) approach, which is more focused on applying safety and ergonomics knowledge and techniques (ISO 9241-210: 2010). Therefore, such an approach aims to improve human well-being, together with satisfaction and accessibility, while preventing the potential side effects on human health, safety, and performance (Gualtieri et al., 2020; Yu, 2019). To build up production systems with direct HRC, cobots with integrated safety features are needed.

## SAFETY REQUIREMENTS IN THE DESIGN OF A HRC

Traditional industrial robots can handle high repetitive and payload tasks (ABB Robotics, 2019). However, in complex assembly systems, this is too expensive to achieve and dangerous to human operators (Hagele et al., 2002). On the other hand, a collaborative robot is equipped with safety components. During HRC, sensors built into the cobot detect the presence of a human in the collaborative workspace and thus ensure the safe performance of a manual operation and the safety of humans and the surrounding work environment. To avoid collision in a shared workplace, the position of the operator has to be known in real-time (Ahmad and Plapper, 2015). Also, the moving trajectory of the operator and speed of movement has to be assessed continuously.

During the collaborative task, the robot relates to the operator through intuitive interfaces. However, the robot's trajectory might be unsafe for the operator and the surrounding work environment. Also, unwanted and unexpected contact between the human and the robotic system may cause injuries and therefore limit the potential for collaboration. Nowadays, there is a lack of simple and practical tools for helping system designers overcome such limiting conditions (Gualtieri et al., 2022). Consequently, safety requirements and measures for collaborative robotics must be studied and harmonized (Gualtieri et al., 2021).

In 2016, a new ISO technical report, ISO TS 15066 (ISO 2016), was published in order to help production technicians and safety experts with the development of safely shared workspaces and with the risk assessment process. This report specifies in greater detail the previous safety requirements for industrial robots included in ISO 10218 parts 1 and 2 (ISO 2011a, b). It also includes requirements and suggestions for collaborative applications.

The ISO TS 15066 standard (ISO 2016) introduces four methods for safe HRC:

- a. Safety-rated monitored stop (SRMS): the robot's motion is stopped when an operator enters the collaborative workspace. SRMS represents the simplest type of collaboration. There are applications where the robot shares a part or all of its workspace with operating staff. In the shared area, the robot and the operator can work, but not at the same time.
- b. Hand guiding (HG): the operator can fully control the robot's motion through direct physical interaction. The robot learns and repeats the motion without the interaction of the operator. In this case, the robotic task is manually guided by the operator at a certain safe velocity by moving the arm through a direct input device at or near the end-effector.

For improving workplace safety and avoiding a collision, there is an enable button in the grabbing area, because the robot can only move if the button is pressed, otherwise, it will stop.

The robot has to be equipped with a measurement device to monitor the impact load. Some robots have sensitive elements embedded directly in their joints. These sensors measure and evaluate the load and control the compliance of the robot.

HG is used in case of a coordinated motion of semi-automated operations or during the programming of the robot. Positions of the desired trajectory are learned according to the guidance of the manipulator by the operator (Vysocky and Novak, 2016).

Hand guiding is applied in limited or small-batch production as a robotic lift assist. The robot can achieve better ergonomics when carrying heavy objects. In that case, operators only need to deal with a small guiding force.

- c. Speed and separation monitoring (SSM): the control system of the robot is actively monitored by the relative speed and distance between the robot and the operator. The operator has access to the shared workspace while the robot is running, but as the operator gets closer to the robot, its speed reduces accordingly. The distance between the robot and the operator can be monitored with lasers. Also, lasers or cameras may monitor the operator's path.

This method is designed to prevent unexpected contact between the operator and the collaborative



robot by reducing the probability to fit the safety limits.

Appropriate sensors detect the worker in the collaborative workspace. Furthermore, this information must be used by the robot controller so that the robot's speed is adjusted to avoid moving contact with the worker. With SSM, the workspace of the robot cell is divided into several areas. These are inspected with scanners or a vision system. In areas out of the reach of the manipulator, where the operator does not come into contact with the robot but can be endangered by a dropped manipulated object, the robot is slowed down to a safe speed. The speed and position of the robot are continually monitored (Vysocky and Novak, 2016).

- d. Power and force limiting (PFL): physical contact between the robot system and the human operator can take place either intentionally or unintentionally. The motion parameters of the robot are monitored with high precision, and even the slightest deviation can be detected. The high precision encoder and high resolution allow the robot to accurately monitor its own speed and position.

The robot can recognize the impact of obstacles and analyze and react to them in a very short time. After a collision, the robot can stop immediately or it can move in the opposite direction, minimizing the impact. Also, the robot can safely react after collisions and readjust its position without interfering with the operator or other systems working in close proximity.

The PFL method is applied in conditions that require frequent operator presence.

The first three collaborative modalities are adopted without the necessity of using an industrial robot that is specifically designed for collaborative applications. The "power and force limiting" is the only collaborative operation that requires robot systems specifically designed for this particular type of operation (ISO 2016).

## PROPOSED HRC ARCHITECTURE

The proposed HRC architecture implies a heterogeneous system, which is deployed in the hybrid human-robot workstation for the conduction of neuroergonomics experiments. Computer systems, interfaces and sensors are integrated into that architecture in order to analyze the workplace condition, habits, and behaviour of operators in the workplace. The proposed setup includes (Savković et al., 2022)

- a collaborative robot;
- a Poka-Yoke system;
- an audio 5.0 system;
- an EEG device;
- a touchscreen PC; and
- a computer.

The proposed framework was inspired by the approach presented in the technical reports by different authors (Arents et al., 2021).

The proposed architecture for an adaptive and modular workstation, in which the operator may work in close proximity to the robot, is presented in Figure 1.

In this collaborative environment, the operator and the collaborative robot perform activities together (Savković et al., 2022). The robot is the primary task performer. Unlike classic robots, cobots have built-in sensors that allow them to recognize and analyze workers' intentions and adapt their activities to the capabilities of the workers (Bonini et al., 2015) by monitoring the physical and cognitive workload of the workers.

This collaborative robot meets the requirements of international robot standards ISO 10218-1 and ISO/TS15066. The specific nature of the robot is reflected in the fact that it is more accurate, easier to reprogram, and can communicate securely with operators (Cherubini et al., 2016). Furthermore, it has no sharp edges, and all the dangerous parts are round and smooth. Despite the benefits of collaboration with the robot, the machine may be a source of potential damage in the workplace. In this regard, ISO standards (also called harmonized standards) must be designed to guarantee a safer collaborative environment.

Some of the standard components of this collaborative robot include

- a robotic arm;
- a controller;
- a power cord;
- a safety switch; and
- Memory.

Figure 2 shows the components required for the operation of the collaborative robot. In addition to the robot arm, the controller, and the power cable, the components required for the operation of the robot include a computer (13) with appropriate software, a panic-emergency button (3), a power supply for an auxiliary safety device (8), a switch for setting the operating mode (1), a grounding cable (7), and a manipulator/gripper (12).

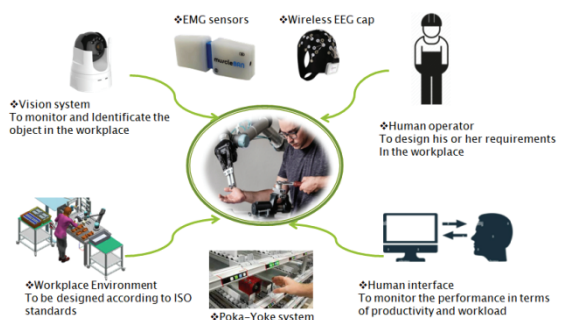
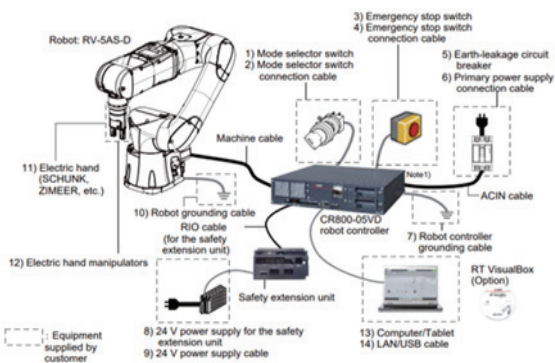


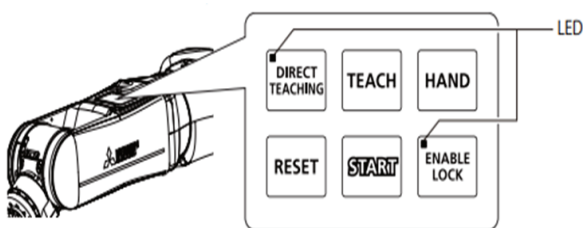
Figure 1: Proposed HRC architecture



**Figure 2.** Basic components necessary for collaborative robot operation

The robot has buttons on the operating panel that corresponds to specific functions, as shown in Table 1 and Figure 3.

Integrated safety elements include a robot controller with safety-rated motion supervision, a sensor system to monitor the collaborative workspace, and grippers with pressure control.



**Figure 3.** Buttons to control the collaborative robot (Mitsubishi Electric)

**Table 1.** Description of buttons on the collaborative robot

BUTTONS	FUNCTION
	It allows manual programming of the robot
	For learning positions where appropriate software is required
	Function related to gripper opening and closing
	Reset after errors
	After stopping the robot, it is necessary to press the START button
	This feature prevents the robot from being controlled by other devices

The position controller ensures that the current position always matches the set point on the commanded motion with a minimum possible difference. The robot's position is controlled by actuators in order to readjust its motion after a collision or deviation. The impedance control is used to measure the force between the manipulator and the human.

The control system supervises the activities of the robot and also sets the limit for the robot to avoid collisions in the environment. This part can manage the position, motion and force, as well as the dynamic effects.

The LED status indicator provides visual assistance when controlling the robot, whereby it immediately warns whether there is a problem or an error during the operation of the robot, which operating mode it is currently in, and at what speed it is operating.

The robot's vision system involves a camera and a software toolkit to enable the robot to obtain data and execute physical response actions. Using the vision system, the collaborative robot will be able to detect and recognize a human face and load a free human hand and any object carried by a human hand. The visual monitoring system involves the use of the camera to track the operator in the human-robot interaction process and achieves visual monitoring through the operator's eye gaze and head position (Song et al., 2001). Collisions can also be predicted by the visual system. In case of a collision, the robot is equipped with passive protection components designed to minimize damage.

Authors used RT Toolbox3 to manage the collaborative robot. This PC software supports everything, from system startup to debugging, simulation, maintenance and operation (Wang and Chang, 2020).

An integrated sensors system ensures the safety of the operator. The sensors, as the most important safety component of the HRC system, are used for internal feedback control and monitoring of external interactions with the environment. Sensors are used for physiological and visual monitoring of human poses and for the behaviour monitoring system during HRC (Bonarini, 2020). The sensors include proprioceptive sensors (position sensors, velocity sensors) and exteroceptive sensors (proximity sensors, range sensors, vision sensors). Proprioceptive sensors focus on the measurement of the internal states of the manipulator – encoders and resolvers are mostly used for the value of the joint position, tachometer for measuring the joint velocity, and force sensors for measuring the force of the end-effector (cobot). On the other hand, the exteroceptive sensors acquire information from the cobot's environment (Soter et al., 2018). The force sensor helps the robot react to the motion of the human hand during task performance.

Physiological monitoring systems comprise wearable devices monitoring the vital operator's parameters during HRC. In this case, the cobot receives these inputs and reacts according to the operator's health status. In this regard, innovative wearable and wireless devices such as EEG, EMG and heart rate sensors are

deployed in HRC in order to enable physiological interaction between the worker and the robot (Villani et al., 2018).

A PC is integrated into this collaborative workstation to monitor and control the performance of various activities/tasks and to allow process visualization. A touchscreen PC is connected to the system for task symbol definition and application of a sound signal. An audio 5.0 system serves to emulate the sounds of the workplace environment.

A Poka-Yoke system enables the prevention of errors and defects due to a drop in attention and concentration in such a way that guides operators through the assembling process and indicates which part they should take at which moment.

An EEG system is used to perform neuroergonomics experiments during HRC in order to measure the subject's neural activity and determine when there is a drop in attention and concentration.

## CONCLUSION

Human-robot collaboration is the main aspect of Industry 4.0. The main reason for the introduction of cobots in the production process is to improve worker safety and health and improve the quality of finished products. Collaborative robots offer flexibility and precision for manual tasks that have previously been difficult to automate. Collaborative robots provide new automation opportunities in areas with a high degree of manual labour. During HRC, collaborative robots perform activities with workers and they are especially beneficial because they protect the workers performing repetitive activities in a dangerous environment.

This research paper presented the human-robot collaboration architecture and showed how to improve workers' safety through the implementation of the proposed architecture. In human-robot workstations, intelligent devices (sensors, computer vision systems, and so on) are integrated in order to protect the operator from hazards, injuries and occupational diseases. The proposed architecture is aligned with safety guidelines regarding HRC.

## REFERENCES

ABB Robotics, IRB7600 Opening a new world of possibilities. (2019). Available at: <https://new.abb.com/products/robotics/industrialrobots/irb-7600>

Ahmad R, Plapper P. Human-Robot Collaboration: Twofold Strategy Algorithm to Avoid Collisions Using ToF Sensor. *International Journal of Materials, Mechanics and Manufacturing*. 2015;4(2):144-7.

Arents, J., Abolins, V., Judvaitis, J., Vismanis, O., Oraby, A., & Ozols, K. (2021). Human-Robot Collaboration Trends and Safety Aspects: A Systematic Review. *J. Sens. Actuator Networks*, 10, 48.

Bonarini, A. (2020). Communication in Human-Robot Interaction. *Current Robotics Reports*, 1, 279 – 285.

Bonini, M., Prenesti, D., Urru, A., & Echelmeyer, W. (2015). Towards the full automation of distribution centers. *2015 4<sup>th</sup> International Conference on Advanced Logistics and Transport (ICALT)*, 47-52.

Cherubini A, Passama R, Crosnier A, Lasnier A, Fraisse P. Collaborative manufacturing with physical human-robot interaction. *Robotics and Computer-Integrated Manufacturing*. 2016; 40:1-13.

Edsinger, A., & Kemp, C.C. (2007). Human-Robot Interaction for Cooperative Manipulation: Handing Objects to One Another. *RO-MAN 2007 – The 16<sup>th</sup> IEEE International Symposium on Robot and Human Interactive Communication*, 1167-1172.

Faccio, M., Bottin, M., & Rosati, G. (2019). Collaborative and traditional robotic assembly: a comparison model. *The International Journal of Advanced Manufacturing Technology*, 102, 1355-1372.

Gervasi, R., Mastrogiacomo, L., & Franceschini, F. (2020). A conceptual framework to evaluate human-robot collaboration. *The International Journal of Advanced Manufacturing Technology*, 108, 841-865.

Gualtieri, L., Palomba, I., Wehrle, E., & Vidoni, R. (2020). The Opportunities and Challenges of SME Manufacturing Automation: Safety and Ergonomics in Human-Robot Collaboration. *Industry 4.0 for SMEs*.

Gualtieri, L., Rauch, E., Vidoni, R., & Matt, D.T. (2020). Safety, Ergonomics and Efficiency in Human-Robot Collaborative Assembly: Design Guidelines and Requirements. *Procedia CIRP*, 91, 367-372.

Gualtieri, L., Rauch, E., & Vidoni, R. (2021). Methodology for the definition of the optimal assembly cycle and calculation of the optimized assembly cycle time in human-robot collaborative assembly. *The International Journal of Advanced Manufacturing Technology*.

Gualtieri, L., Rauch, E., & Vidoni, R. (2022). Development and validation of guidelines for safety in human-robot collaborative assembly systems. *Comput. Ind. Eng.*, 163, 107801.

Hagele M., W. Schaaf, and E. Helms, "Robot assistants "Robot assistants" at manual workplaces – Effective co-operation and safety aspects," Proceedings of the 33<sup>rd</sup> International Symposium on Robotics (ISR), p. 6, 2002.

Hermann, M., Pentek, T., & Otto, B. (2016). Design Principles for Industry 4.0 Scenarios. *2016 49<sup>th</sup> Hawaii International Conference on System Sciences (HICSS)*, 3928-3937.

International Organization for Standardization (2010). Safety of Machinery – General Principles for Design-Risk Assessment and Risk Reduction (ISO 12100:2010). <https://www.iso.org/standard/51528.html>.

International Organization for Standardization (2011). Robots and Robotic Devices – Safety Requirements for Industrial Robots – Part 2: Robot Systems and Integration (ISO 10218-2:2011). <https://www.iso.org/standard/41571.html>.

International Organization for Standardization (2011). Robots and Robotic Devices – Safety Requirements for Industrial Robots – Part 1: Robots (ISO 10218-1:2011). <https://www.iso.org/standard/51330.html>.

International Organization for Standardization (2016). ISO TS 15066 – Robots and Robotic Devices – Collaborative Robots (ISO/TS 15066:2016). <https://www.iso.org/standard/62996.html>.

International Organization for Standardization (2018). Robotics – Safety Design for Industrial Robot Systems – Part 1: End-Effectors (ISO/TR 20218:2018). <https://www.iso.org/standard/69488.html>.

International Federation Robotics. (2020) Demystifying Collaborative Industrial Robots. In. *Positioning paper*: IFR.

Kadir, B.A., Broberg, O., & Conceição, C.S. (2018). Designing human-robot collaborations in industry 4.0: explorative case studies

Krger, J., Surdilovic, D., 2008. Robust control of force-coupled humanrobot-interaction in assembly processes. *CIRP Annals – Manufacturing Technology* 57.1, pp. 41-44

KUKA, “Many wrenches make light work: KUKA flexFELLOW will provide assistance during drive train pre-assembly,” 2016. [Online]. Available at: <https://www.kuka.com/en-de/press/news/2016/10/vw-commits-to-human-robot-collaboration-inwolfsburg>

Matheson, E., Minto, R., Zampieri, E. G., Faccio, M., Rosati, G. Human–robot collaboration in manufacturing applications: A review, *Intel. Syst. Contr. Aut.* 8 (2019) 100

Mitsubishi Electric. Retrieved from: <https://dl.mitsubishielectric.com/dl/fa/document/manual/robot/bfp-a3727/bfp-a3727f.pdf>

Nelles, J., Kuz, S., Mertens, A., & Schlick, C.M. (2016). Human-centered design of assistance systems for production planning and control: The role of the human in Industry 4.0. *2016 IEEE International Conference on Industrial Technology (ICIT)*, 2099-2104.

Savković, M., Caiazzo, C., Đapan, M., Vukicevic, A.M., Pušica, M., & Macuzic, I. (2022). Development of Modular and Adaptive Laboratory Set-Up for Neuroergonomic and Human-Robot Interaction Research. *Frontiers in Neurorobotics*, 16.

Song, W., Kim, D., Kim, J., & Bien, Z.Z. (2001). Visual servoing for a user's mouth with effective intention reading in a wheelchair-based robotic arm. *Proceedings 2001 ICRA. IEEE International Conference on Robotics and Automation (Cat. No.01CH37164)*, 4, 3662-3667 vol. 4.

Soter, G., Conn, A.T., Hauser, H., & Rossiter, J.M. (2018). Bodily Aware Soft Robots: Integration of Proprioceptive and Exteroceptive Sensors. *ICRA*.

Tan, Q., Tong, Y., Wu, S., & Li, D. (2019). Anthropocentric Approach for Smart Assembly: Integration and Collaboration. *J. Robotics*, 2019, 3146782:1-3146782:8.

Villani, V., Pini, F., Leali, F., & Secchi, C. (2018). Survey on human–robot collaboration in industrial settings: Safety, intuitive interfaces and applications. *Mechatronics*.

Vysocký, A., & Novák, P. (2016). HUMAN – ROBOT COLLABORATION IN INDUSTRY. *MM Science Journal*, 2016, 903-906.

Wang, W., Chang, H. (2020). Mitsubishi Electric’s robot teaching course design. *2020 International Conference on Mathematics and Computers in Science and Engineering (MACISE)*, 223-228.

Weiss, A., Wortmeier, A., & Kubicek, B. (2021). Cobots in Industry 4.0: A Roadmap for Future Practice Studies on Human–Robot Collaboration. *IEEE Transactions on Human-Machine Systems*, 51, 335-345.

Yu, C. (2019). Human-Robot Collaboration Analyzing the safety for human-robot collaboration in automotive industry.

## ACKNOWLEDGEMENTS

This research paper has been financed by the European Union’s H2020 research project under the Marie Skłodowska-Curie Actions Training Network Collaborative Intelligence for Safety-Critical Systems(Grant Agreement ID: 955901).

## BIOGRAPHY of the first author

**Carlo Caiazzo** is born in Naples, Italy, in 1995.

He graduated in Mechanical Engineering for Design and Production at the University of Naples Federico II, Italy.



He is currently working as a Ph.D. student at the Faculty of Engineering, University of Kragujevac. He also works as an early-stage researcher in the Marie-Sklodowska Curie European project CISC (Collaborative Intelligence for Safety-Critical Systems)- <https://www.ciscproject.eu/>. His research study is related to the architecture and design of the system to acquire physiological data in the workplaces of the future.







DARIO JAVOR<sup>1</sup>  
DEJAN KRSTIĆ<sup>2</sup>

<sup>1,2</sup> University of Niš,  
Faculty of Occupational Safety

<sup>1</sup>dario.javor@znrfak.ni.ac.rs  
<sup>2</sup>dejan.krstic@znrfak.ni.ac.rs

## ENVIRONOMIC SCHEDULING OF DISTRIBUTED ENERGY SOURCES IN MICROGRIDS

**Abstract:** *Microgrids will have an increasingly prominent role in the future power systems. They are defined as small-scale power systems that include distributed energy sources, storage devices, non-deferrable loads and controllable loads. Microgrids can operate connected to the main grid or isolated from it. Distributed energy sources include dispatchable sources (such as microturbines, fuel cells and diesel engines) and non-dispatchable renewable energy sources (such as wind turbines and photovoltaic panels).*

*An environomic (environmental/economic) power dispatch refers to an efficient microgrid operation by minimizing fuelling and maintenance costs of electricity generation in the microgrid and the emissions from internal electricity generation or external production from the main grid. This paper analyses of different types of dispatchable generators in microgrids from the environomic point of view. The results are obtained by using the multi-criteria optimization method. Generators of the microgrid are ranked by the PROMETHEE method.*

**Key words:** distributed energy sources, microgrid, multi-criteria optimization, PROMETHEE.

## INTRODUCTION

Microgrids are defined as small-scale power systems that include distributed energy sources, storage devices, non-deferrable loads and controllable loads. They can operate connected to the main grid or in an island mode. If they are working isolated from the grid, microgrids include non-dispatchable renewable energy sources (usually wind generators and/or photovoltaic panels) and dispatchable sources (such as microturbines, fuel cells, diesel engines, small modular nuclear reactors, etc.).

An environomic (environmental/economic) choice of generators in a microgrid can be treated as a multicriteria optimization problem (MCO). Operational & maintenance and fuel costs of electricity generation, as well as emissions from internal electricity generation of the microgrid and external production from the main grid, should be minimized. The emissions of CO<sub>2</sub>, SO<sub>2</sub>, CO, NO<sub>x</sub>, other harmful gases and particulate matter (PM) as products of electricity production are primarily responsible for global warming. For the protection of the environment, they should be as low as possible. These parameters of the optimization problem are analysed in the following section.

A diesel generator, a microturbine, a fuel cell and a main grid are analysed in this paper as electricity producers for the microgrid. They represent a set of possible alternatives for the optimization problem. Operational & maintenance and fuel costs (OMF),

emissions of CO<sub>2</sub>, SO<sub>2</sub>, CO, NO<sub>x</sub>, and PM constitute a set of evaluation criteria. The multicriteria optimization problem is defined by the following equation:

$$\max \{g_1(a), g_2(a), \dots, g_k(a) \mid a \in A\}. \quad (1)$$

where  $A$  is the finite set of possible alternatives  $\{a_1, a_2, \dots, a_n\}$  and  $\{g_1(\cdot), g_2(\cdot), \dots, g_k(\cdot)\}$  is the set of evaluation criteria. In a general case, any criterion can be maximized or minimized. In the presented example the costs and the emissions are minimized.

For solving such problems, J.P. Brans developed the PROMETHEE I method for partial ranking and the PROMETHEE II method for complete ranking (Brans, 1982). This author later developed the PROMETHEE III method for ranking based on intervals and the PROMETHEE IV method for continuous case (Brans, Mareschal, Vincke, 1984). PROMETHEE stands for the Preference Ranking Organization METHod for Enrichment of Evaluations. The same authors proposed the visual interactive module GAIA in 1988, providing graphical representation supporting the PROMETHEE methodology. GAIA stands for the Graphical Analysis for Interactive Aid software. There are also extensions of the method (Brans, Mareschal, 2005), such as PROMETHEE V, including segmentation constraints, and PROMETHEE VI (representation of the human brain). The results in this paper are obtained by applying PROMETHEE I and PROMETHEE II methods. Different scenarios are compared by using

PROMETHEE-GAIA (Mareschal, 2011). The results of comparison and conclusions are given in the paper.

**PROBLEM FORMULATION**

**Emissions of gases as evaluation criteria**

Emissions of harmful gases and particulate matter from electricity production contribute to the global warming, formation of toxic chemicals, ground-level ozone (smog), acid rain, health problems (respiratory, cardiovascular, nervous system effects), water quality deterioration, atmospheric deposition, deterioration of buildings and monuments, visibility impairment, etc. All the gases can be transported by winds over very long distances through the atmosphere, so this poses a global problem of environmental pollution.

Carbon dioxide (CO<sub>2</sub>) is formed when fuel containing carbon is burned. Carbon monoxide (CO) is formed during incomplete combustion of fuels. Sulfur dioxide (SO<sub>2</sub>) is formed when fuel containing sulfur is burned. If fuel burns at very high temperatures, then nitrogen oxides (NO<sub>x</sub>) are formed. NO<sub>x</sub> are highly reactive compounds. Particulate matter (PM) refers to particles in the air such as dust, dirt, soot, smoke and liquid droplets.

Some data for the emissions of different generators during electricity production can be found in (Martí, 2005). The data for the emissions of CO<sub>2</sub>, SO<sub>2</sub> and NO<sub>x</sub> for the diesel generator, the microturbine and the fuel cell are taken from (Murty, Kumar, 2020) and given in Table 1.

For diesel generators the emissions are estimated as follows: NO<sub>x</sub> emissions at 0.5 g/kWh, CO<sub>2</sub> emissions at 697 g/kWh, and SO<sub>2</sub> at 0.22 g/kWh. CO emissions are estimated at 1 g/kWh and PM emissions at 0.2 g/kWh (EPRI report, 2003).

**Table 1.** Electricity production alternatives in the microgrid and their technical and operating characteristics

Generator's parameter	Diesel generator (DG)	Micro turbine (MT)	Fuel cell (FC)	Main grid (MG)
Operational & maintenance and fuel costs (OMF) [\$/kWh]	0.15	0.11	0.242	0.2
CO <sub>2</sub> [g/kWh]	697	670	441	889
SO <sub>2</sub> [g/kWh]	0.22	0.0036	0.0022	1.8
NO <sub>x</sub> [g/kWh]	0.5	0.186	0.0136	1.6
CO [g/kWh]	1	0.4	0.01	0.01
Particulate matter (PM) [g/kWh]	0.2	0	0.01	0.3

Microturbines are very small combustion engines. In most configurations they are single shaft machines. They have the compressor and turbine mounted on the same shaft. Microturbines are suitable to generate electrical and thermal energy in the microgrid. The emissions of harmful gases and PM in g/kWh are lower than for diesel generators. They produce CO<sub>2</sub> emissions of about 670 g/kWh, SO<sub>2</sub> emissions of 0.0036 g/kWh, NO<sub>x</sub> emissions of 0.186 g/kWh, CO emissions of 0.4 g/kWh, and zero PM emissions (Table 1).

Electricity in a fuel cell is produced without combustion or mechanical work. Most emissions originate from the fuel processing system. Fuel cells have NO<sub>x</sub>, SO<sub>2</sub>, CO and PM emissions lower than 0.01 g/kWh. CO<sub>2</sub> emissions vary in the range of 218–623 g/kWh (EPRI report, 2003).

For the main grid, the data is taken from (Wu, 2014).

The data in Table 1 are given for the four electricity production alternatives in the microgrid.

**Operational & maintenance and fuel costs as an evaluation criterion**

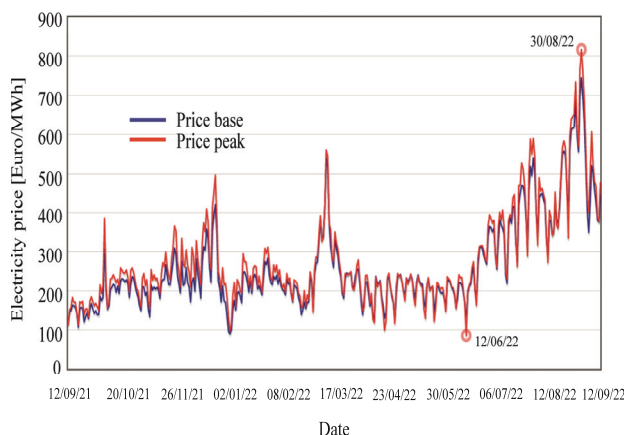
Operational & maintenance costs are usually about 10% of the operational & maintenance and fuel costs in total, so the values from (EPRI report, 2003) for the diesel generator, the microturbine and the fuel cell are multiplied by ten. The main grid costs (Table 1) are taken relative to other generators' costs. These costs depend on the share of coal, diesel, or other fuel used for electricity production, which also determines the emissions of harmful gases. For example, the electricity market price was 556.65 €/MWh ≈ 0.555 \$/kWh on 28<sup>th</sup> August, 2022 (SEEPEx, 2022), due to the global energy crisis, but this is in the same ratio compared to the OMF costs of other alternatives, so it has no influence on the results of the generators' ranking. The change of electricity market prices in the last year is given in Fig. 1.

**Different scenarios**

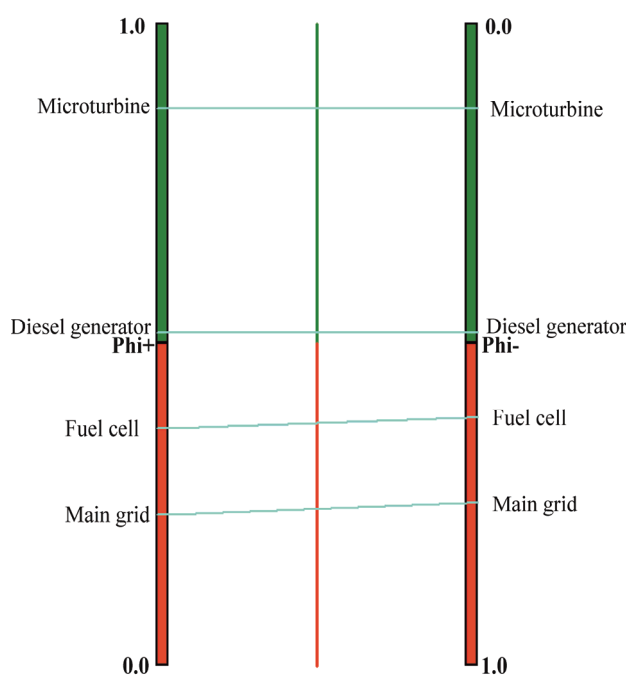
In the first scenario, the weight of OMF costs as the main criterion is 60%, the weights of emissions for CO<sub>2</sub>, SO<sub>2</sub>, and NO<sub>x</sub> are 10%, and the weights of emissions for CO and PM are 5%.

In the second scenario, the weight of OMF costs, as the most important criterion, is 40% (the value is lower than in the first scenario). The weights of emissions are increased to 15% for CO<sub>2</sub>, SO<sub>2</sub> and NO<sub>x</sub>, and 7.5% for CO and PM. The results of the generators' ranking are different for the two scenarios.

In the third scenario, the OMF costs are 0.14 \$/kWh and all other evaluation criteria are the same as in the second scenario. The OMF costs for the first and the second scenario are 0.2 \$/kWh. Last year, the prices of electricity were in the range of 0.085 – 0.816 \$/kWh.



**Figure 1.** SEEPEX electricity market prices graph for the 12/09/2021 – 12/09/2022 period

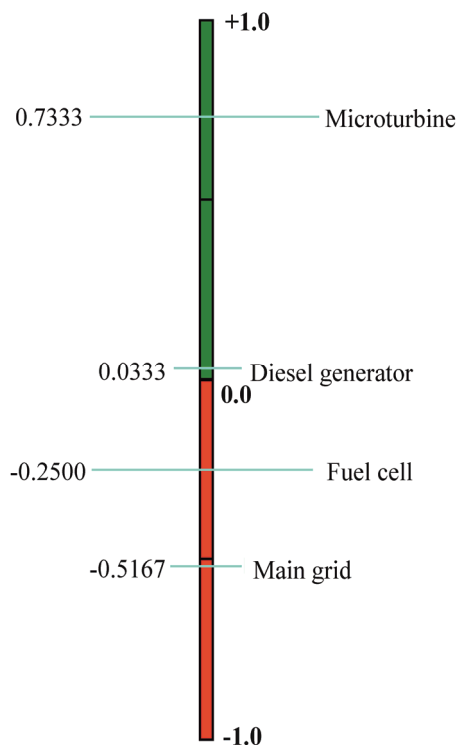


**Figure 2.** PROMETHEE I results of the partial ranking for Scenario 1

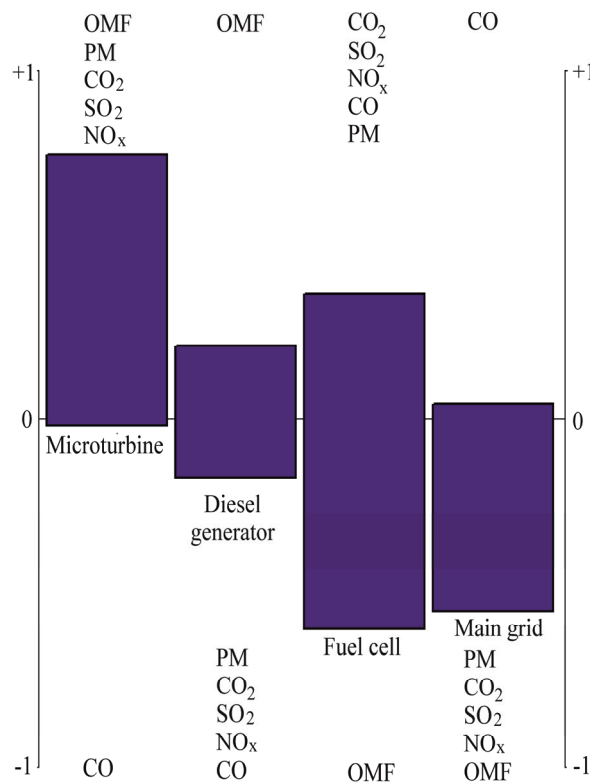
## ANALYSIS OF RESULTS

### Scenario 1

The results of using PROMETHEE I for the partial ranking of generators in Scenario 1 are given in Fig. 2. The results of using PROMETHEE II for the complete ranking of generators in Scenario 1 are given in Fig. 3. Fig. 4 gives the results for Scenario 1 obtained by applying PROMETHEE-GAIA. For all the evaluation criteria except for CO emissions, the microturbine presents the best choice. The ranking of the microturbine criteria is also given (OMF, PM, CO<sub>2</sub>, SO<sub>2</sub>, NO<sub>x</sub>). The main advantage of the diesel generator is its OMF cost, which is also the greatest disadvantage of the fuel cell.



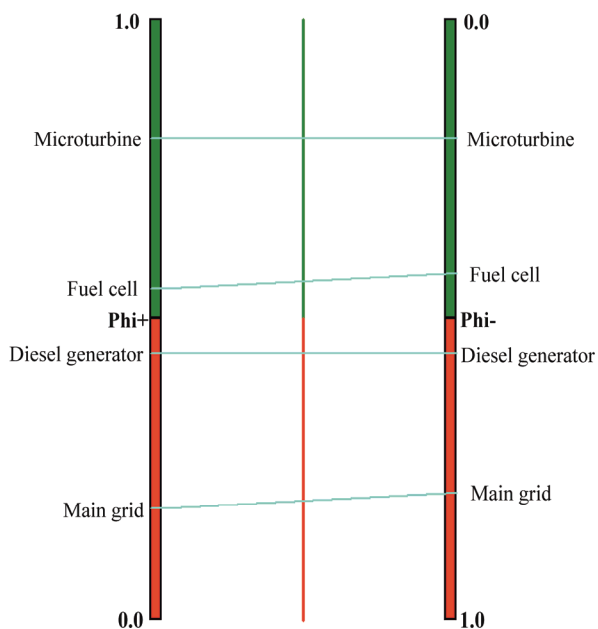
**Figure 3.** PROMETHEE II results of the complete ranking for Scenario 1



**Figure 4.** PROMETHEE rainbow for Scenario 1

**Table 2.** Flow table for Scenario 1

Rank	Alternative	Phi	Phi+	Phi-
1	Microturbine	0.7333	0.8667	0.1333
2	Diesel generator	0.0333	0.5167	0.4833
3	Fuel cell	-0.2500	0.3667	0.6167
4	Main grid	-0.5167	0.2333	0.7500



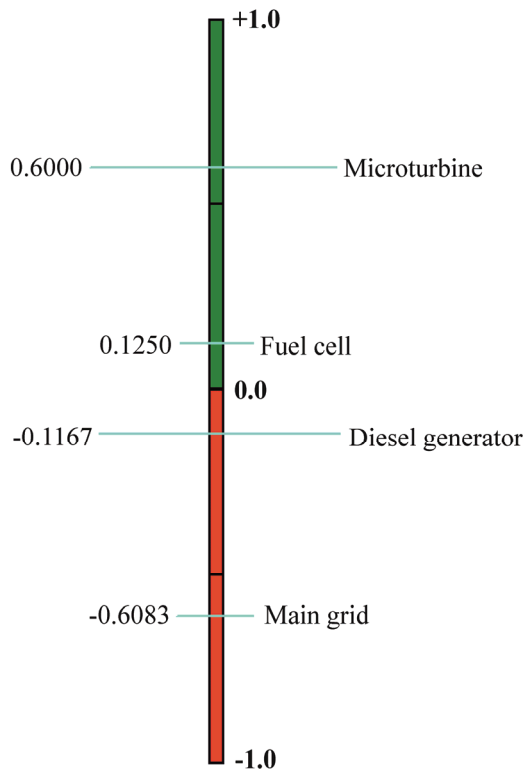
**Figure 5.** PROMETHEE I results of the partial ranking for Scenario 2

In the complete ranking of alternatives for Scenario 1 the microturbine is the best choice, as shown in Table 2, followed by the diesel generator, the fuel cell, and the main grid.

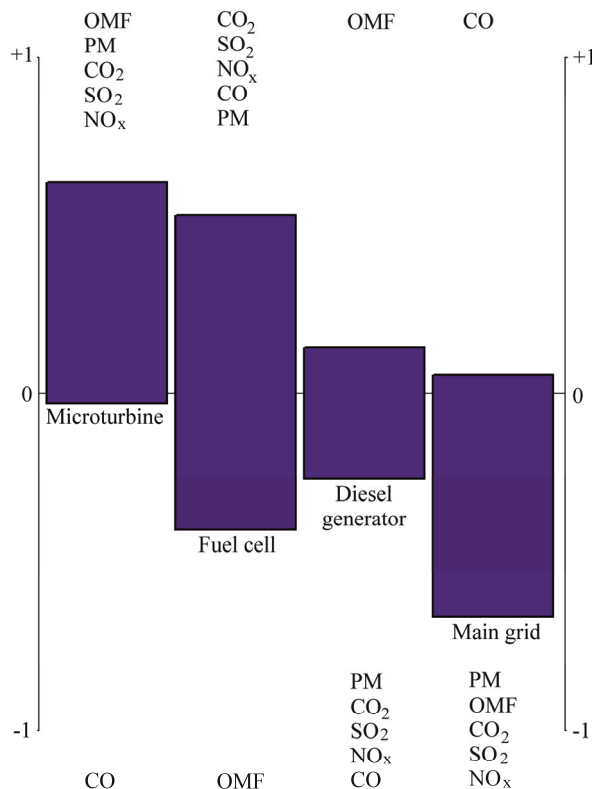
The values of the flow  $\Phi^+$ ,  $\Phi^-$ , and  $\Phi = (\Phi^+) - (\Phi^-)$  are also given in Table 2.

**Scenario 2**

OMF costs in Scenario 2 are considered with a lower weight (40%) than in Scenario 1 (60%). The results of using PROMETHEE I for the partial ranking of generators in Scenario 2 are given in Fig. 5.



**Figure 6.** PROMETHEE II results of the complete ranking for Scenario 2



**Figure 7.** PROMETHEE rainbow for Scenario 2

**Table 3.** Flow table for Scenario 2

Rank	Alternative	Phi	Phi+	Phi-
1	Microturbine	0.6000	0.8000	0.2000
2	Fuel cell	0.1250	0.5500	0.4250
3	Diesel generator	-0.1167	0.4417	0.5583
4	Main grid	-0.6083	0.1833	0.7917

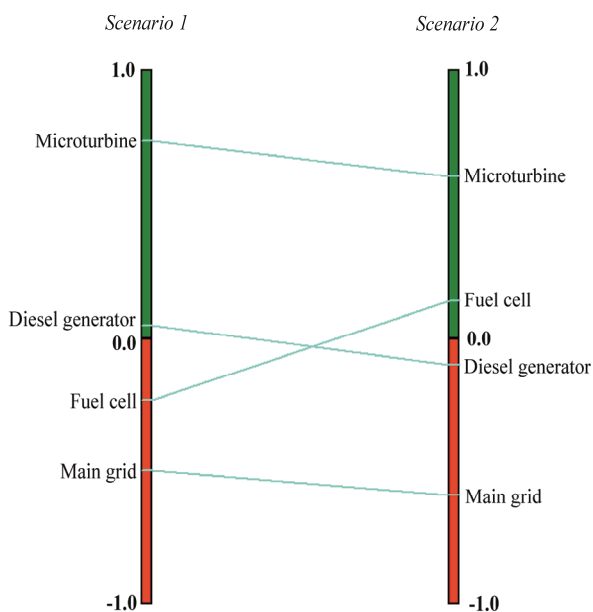
The results obtained by applying PROMETHEE II for the complete ranking are given in Fig. 6.

The microturbine is the best choice just as in Scenario 1. For all the evaluation criteria except for CO emissions, the microturbine is the best choice (Fig. 7).

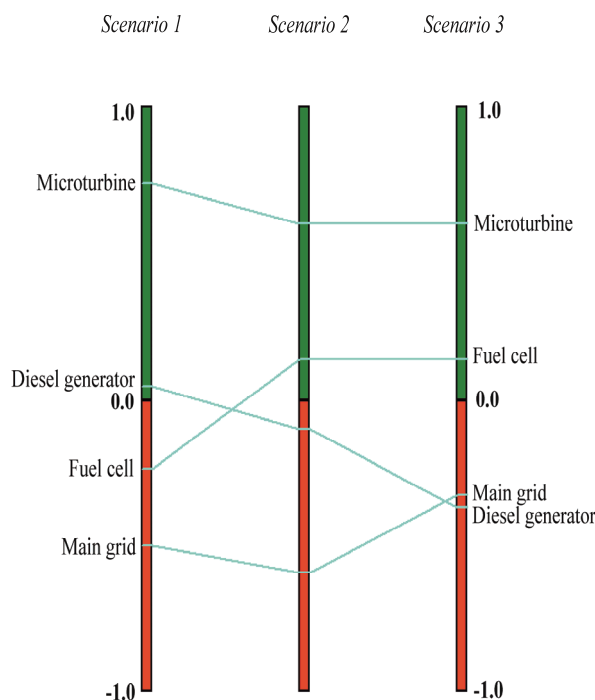
In Scenario 2, the second place in the ranking is taken by the fuel cell, whereas the diesel generator is in the third place. The main grid is in the fourth place in the ranking of generators, as presented in Table 3.

**Scenario 3**

In Scenario 3, the OMF costs are 0.14 \$/kWh and other evaluation criteria are the same as in Scenario 2. In Scenario 3, the main grid would be a better choice than the diesel generator.



**Figure 8.** Comparison of Scenario 1 (on the left) and Scenario 2 (on the right)



**Figure 9.** Comparison of Scenario 1 (on the left), Scenario 2 (in the middle) and Scenario 3 (on the right)

**Comparison of the scenarios**

The comparison of ranking results for Scenarios 1 and 2 is given in Fig. 8. The results are obtained by using PROMETHEE-GAIA software. The comparison of ranking results for the three scenarios is given in Fig. 9, for the same OMF costs of other generators in Scenario 3 as in Scenarios 1 and 2, except for the main grid.

**CONCLUSION**

This paper analysed the problem of ranking dispatchable generators in the microgrid from the environomic point of view. Operational & maintenance and fuel costs as well as emissions of harmful gases were taken as the evaluation criteria for the microgrid electricity production by a microturbine, a fuel cell, a diesel generator and a main grid.

From the environmental point of view, the fuel cell would be the best choice, but the analysis of the results showed that the microturbine would be the best choice from the environomic point of view.

The ranking of generators in a microgrid mainly depends on the fuel costs that have varied a lot over the previous year. Therefore, application of the multicriteria optimization method and ranking of generators is necessary for the optimal operation of the microgrid.



## REFERENCES

Brans, J.P. (1982). L'ingénierie de la décision; Elaboration d'instruments d'aide à la décision. La méthode PROMETHEE. In: Nadeau R., Landry M., (Eds.), *L'aide à la décision: Nature, Instruments et Perspectives d'Avenir*, Québec, Canada. Presses de l'Université Laval, pp.183–213.

Brans, J.P., Mareschal, B., Vincke, Ph. (1984). PROMETHEE: A new family of outranking methods in multicriteria analysis. In: Brans, J.P., (Ed.), *Operational Research '84*, North-Holland, Amsterdam, pp.477-490.

Brans, J.P., Mareschal, B. (2005). PROMETHEE methods. In: Figueira, J., Greco, S., Ehrgott, M. (Eds.), *Multiple Criteria Decision Analysis: State of the Art Surveys*, Springer Science + Business Media, Inc., pp.163–196.

EPRI report (2003). Installation, Operation, and Maintenance Costs for Distributed Generation Technologies, *EPRI, Palo Alto, CA: 2003. 1007675*.

Mareschal, B. (2011) [online], available: <http://en.promethee-gaia.net> [Accessed 12 Aug 2022].

Marti, B. (2005). *Emissions of Power Delivery Systems*. Semester Thesis PSL0502 EEH – Power Systems Laboratory, Swiss Federal Institute of Technology (ETH) Zurich.

Murty, V.V.S.N., Kumar, A. (2020). 'Multi-objective energy management in microgrids with hybrid energy sources and battery energy storage systems', *Prot Control Mod Power Syst* 5, 2. <https://doi.org/10.1186/s41601-019-0147-z>

SEE Power EXchange (2022) [online], available: <http://www.seepex-spot.rs/sr> [Accessed 26 Aug 2022].

Wu, H., Liu, X., Ding, M. (2014). 'Dynamic economic dispatch of a microgrid: mathematical models and solution algorithm', *Int. J. Electr. Power Energy Syst.* 63, pp.336-346.

## ACKNOWLEDGEMENTS

This research was financially supported by the Ministry of Education, Science and Technological Development of the Republic of Serbia, according to contract No. 451-03-68/2022-14/ 200148.

## BIOGRAPHY of the first author

**Dario Javor** was born in Niš, Serbia, in 1992. He received B.Sc. diploma in Electrical engineering and computer science, and Master degree in Power engineering from the Faculty of Electronic Engineering, University of Niš.



He is currently working as an assistant at the Faculty of Occupational Safety in Niš, University of Niš. His main areas of research include renewable energy sources, smart grids, electric vehicles, optimization methods, electromagnetic compatibility, etc.

KRISTINA RADOJEVIĆ<sup>1</sup>

<sup>1</sup> University of Belgrade,  
Faculty of Security Studies

<sup>1</sup>kristinaradojevic@gmail.com

## INTEGRATED MANAGEMENT OF SAFETY AND SECURITY – THEORETICAL ASPECTS

**Abstract:** *The aim of this paper is to analyze theory and practical aspects and possibilities of the integration of safety and security management systems (SMSs and SeMSs) based on their basic common elements. An integrated safety and security management system implements safety and security management processes and activities. An overview of definitions of safety and security management is given and it explains the content of an Integrated Management of Safety and Security (IMSS). A possible model for the IMSS is proposed.*

**Key words:** integrated management of safety and security (IMSS), safety management system (SMS), security management system (SeMS), management systems.

## INTRODUCTION

Our world is interconnected today more than ever before. Safety and security threats are therefore even closer to the organizations and raise bigger issues. In order to manage those threats efficiently, we suggest that organizations adopt an integrative approach to safety and security.

The idea of integrating Security and Safety Management Systems is not new. It stemmed from an idea of an Integrated Management System (IMS). The tendency toward increased compatibility between different management standards has raised the question about different aspects of integration, but it also initiated a debate on integration of safety and security. In most theories and industries, safety and security issues are treated separately (De Maggio et al., 2019). But one should bear in mind that many cases showed that experts should collaborate in practice in order to efficiently manage safety and security (Gilligan, 2021; Harvey and Stanton, 2014). Furthermore, the perspective of systems thinking in the safety literature over the past decades invites organizations to move away from focusing on individual systems components towards a more integrated view of factors that influence their performance in the context of larger socio-technical systems (Karanikas et al., 2022).

Even though there are differences between the scope and approach to risks between safety and security systems, the arguments for integration are being presented with increased frequency. The aim of this paper is to analyze the theoretical and practical aspects and possibilities of this integration. The paper describes safety and security management systems (SMSs and SeMSs), based on their basic common elements and proposes a possible model for the integration of those systems.

## SAFETY AND SECURITY MANAGEMENT SYSTEMS

### Safety Management System (SMS)

Safety is a very complex and broad term, but it is usually defined as “freedom from ‘something’ that could have negative consequences, such as harm to humans or animals, economic loss, or any other form of damage or loss” (Li and Guldenmund, 2018). That means that safety is the condition in which unforeseen events are being avoided.

A Safety Management System (SMS) is a concept that has the purpose of efficient and effective management of safety. It is a continuous and adjustable process and it enables the normal functioning of the organization (Živković and Palačić, 2015). An SMS is commonly defined as the management procedures, elements and activities that aim to improve the safety performance of and within an organization (Li and Guldenmund, 2018). Detailed characteristics of the systems may vary from one industry to another due to different views on safety. It is difficult to define a generic SMS. However, all SMSs have similar features (Bieder, 2021): a definition of the organizational structure, including objectives, policies and accountabilities; an analysis of operational risks; a definition of a safety assurance process (including the risk control measures); and a risk communication process. It could be argued that an SMS consists of a safety philosophy and policy, safety culture, risk analysis and elements such as training, education, definition of responsibilities, continuous improvements and communication (Radojević, 2012). Social elements are of great importance for SMSs, since they relate to human resources, conflict management and problem-solving (Živković and Palačić, 2015).

As safety management focuses on managing risk, the structure of a risk management system sometimes represents a rough SMS, but it is only a part of a complete SMS (Li and Guldenmund, 2018). A safety management system reflects an organization's commitment to safety and represents an important factor, which has an influence on employees' understanding of safety. It is a set of policies and procedures that aim to positively influence employees' attitudes and behaviour toward risks. In turn, those behaviours decrease unsafe activities. The main goal of this system is to raise awareness of safety, understandings, motivation and commitment of all employees. Thus, the system of safety management becomes a precondition for establishing a positive safety climate. Safety climate incorporates employees' attitudes and their understanding of the importance of organizational safety (Radojević, 2012).

The domains of safety in business organizations are broad, and they include occupational health and safety, fire safety, environmental safety, personal, privacy and data protection, and business intelligence (Živković and Palačić, 2015). In order to regulate these domains and to enable organizations to improve their operation, health and safety, different standards have been established. All of the international standards, such as ISO 9001, ISO 14001, ISO 27001, ISO 45001 and SA8000 are compatible with one another, and there are efforts by many organizations to develop and implement an Integrated Management System (IMS), which would use a Total Quality Management (TQM) approach (Jørgensen, Remmen and Mellado, 2006). One of the main standards for creating an SMS is ISO 45001 (OHSAS 18001). At this point, it should be noted that there is a tendency to integrate safety and environmental management systems into SEMS. These systems are a requirement for industries that pose environmental hazards (Will, 2020). Nevertheless, it is important that each organization develop a management system to meet its own needs.

### **Security Management System (SeMS)**

Until the end of the Cold War, security was connected to state security and protection against threats from foreign countries. When the Cold War ended, security focused on peace and human rights, and especially on terrorism and sabotage. It is worth noting that until the 9/11 attacks in New York, security threats had not been taken into proper consideration by regulatory bodies and organizations (Pettersen Gould and Bieder, 2020). Nowadays, security is an integral part of many organizations' everyday activities, especially in some sensitive industries, such as chemical processing and transportation. Security can be defined in terms of the system state being free from threats or vulnerabilities, i.e. potential losses, where vulnerability is a weakness in a product, leaving it open to a loss (Leveson, 2020). As Leveson (2020) states, the difference between physical security and cyber-security is irrelevant, since cyber-security focuses on one aspect of system design, while physical security has a broader scope.

A Security Management System (SeMS) is an approach to managing security that integrates security management into the everyday activities of an organization. It provides the organizational structure, policies and procedures, as well as responsibilities and accountabilities, in order to ensure effective oversight. A SeMS may thus be understood as an assurance system for security (UKCAA, 2021).

A Security Management System provides a framework of principles and guidance aimed at enhancing security performance by proactively managing risks, threats, and vulnerabilities that may have a negative impact on that performance. A SeMS contributes to proactive security practices. It offers benefits that can improve performance and communication within a company, as well as compliance with legal regulations (Whyte, 2021).

A SeMS includes a security philosophy, security policy and culture, risk analysis, incident reports, and elements such as education, responsibilities, continuous improvement and communication (UKCAA, 2021). In addition, its implementation is dependent on the support by the top management.

### **INTEGRATION OF SAFETY AND SECURITY MANAGEMENT SYSTEMS – ARGUMENTS FOR AND AGAINST IT**

It needs to be emphasized that there are two schools of thought: one believes that there is a distinct difference between safety and security threats, and the other believes that safety and security are interconnected and the line between them is blurred (Whyte, 2021).

If we consider the differences between safety and security, we may see that the case is not as simple as the theory suggests. One of the main arguments pertains to the nature of threats. In safety, they are unintentional, while security deals with malicious, intentional risks. Other arguments suggest that the consequences are the main reason for treating them separately. Specifically, security tries to avoid influences from the environment, while safety needs to ensure that the organization does not influence the environment (Pettersen Gould and Bieder, 2020). On the other hand, some authors think that consequences are the main reason for integration, because we need to avoid them, regardless of the cause (Leveson, 2020).

Another possible problem with integration is the definition of safety and security culture. There are a lot of approaches that deal with safety culture, but security culture is only partially discussed in the literature. As they deal with different fields of threats, some authors claim that they should be developed separately (Malcolmson, 2019), while some companies claim that it is difficult to separate security from safety culture (Larsen and Østensjø, 2015), and thus from organizational culture (Jore, 2020).

On the other hand, if we adopt the second approach, there is an opportunity to shape and model integrated management of safety and security (IMSS). When safety and security are considered from this

perspective, the IMSS is allowed to be open and prepared for a wide aspect of threats, risks and hazards. Of course, this system has to be adapted to the organization and implemented into its basic processes. But, the main argument for integration is that integrated management of safety and security refers to functions, procedures and practices that ensure that safety, physical security and cyber security risks are (co)identified, (co)analysed (co)assessed, prevented and mitigated. Integration of management can occur at structural, functional and cultural levels in an organization (Jørgensen, Remmen and Mellado, 2006).

The main reasons for integration are explained by different motivations: economic (cost efficiency), mutual interactions between safety and security, avoiding conflicts (a need for coordination between safety and security), and different views on risks (Ylönen et al., 2022).

Yet another argument for integration is presented through the integration of management systems and their generic processes. The generic processes in a management system are the following: top management commitment, definition of a policy, planning of objectives and targets, procedures for training of employees, communication procedures, audits, documentation and records control, control of non-compliance, corrective and preventive actions, and management review. This integration would minimize costs, simplify some procedures and reduce paperwork and documentation (Jørgensen, Remmen and Mellado, 2006).

## **RISK ANALYSIS AS A COMMON ELEMENT OF THE IMSS**

Regardless of what aspect is adopted, one thing that is in common for safety and security is risk analysis. Authors who are against integration argue that the nature of risks is different and that risk assessment is therefore very different for safety and security. Others think that the nature of risk is irrelevant, but the thing that one should focus on is the consequence of the objectives (Blokland and Reniers, 2020).

One possible argument that is also against this integration is cyber-security, since it is considered that cyber security uses a different approach to risk analysis. However, separate risk identifications and analyses in the safety and security domains create gaps and lead to inadequate risk management (Ylönen et al., 2022).

The IMSS should reflect the structural integration of Environment, Health, Safety, and Security management systems, in the sense that it integrates elements from different environmental, safety, and security standards (Ylönen et al., 2022). Yet, it should also include cyber-security. A problem of the integration of safety, physical security and cyber-security through risk analysis is shown in a research study in Seveso plants (Ylönen et al., 2022). In the domain of cyber and physical security, the research showed that IMSS has to address the three main classes of cyber-security related

events: (a) an attack on the Information Technology (IT) system, compromising sensitive data/information; (b) an attack on the Operational Technology (OT) system, leading to loss of production (e.g. production shutdown or product out of specification); and (c) an attack infecting the OT system, aimed at generating a major event. The conclusion is that risk identification techniques that are used in safety domains, such as HAZOP, Process Hazard Analysis, PHA, Failure Modes, Fault Tree Analysis, etc., are not very successful in identifying the potential major events or attacks on the Operational Technology system. Those techniques identify events from random failures or human error, but not from intentional acts. The scenario identification falls outside of the practice of Security and Cyber-Risk Assessment (Matteini et al., 2019). It leads to the adoption of partial assumptions, such as considering the worst-case consequences from the safety assessments in the security risk assessment, even though the cyber-attacks have the potential for consequences different from those considered in the safety study (Ylönen et al., 2022).

In literature, there were several attempts to combine safety and security risk analyses, such as System-Theoretic Process Analysis for Security (STPA-SEC). This method is aimed specifically at safety-critical cyber-physical systems. However, those methods have exposed some problems regarding cross-impacts from one risk domain to another (Ylönen et al., 2022). In order to solve such problems, there is a suggestion to use Process Hazard Analysis of Remote manipulations through the control System (PHAROS). It was developed within the framework of the SAFERA 4STER project as a systematic and formally rigorous methodology (Iaiani et al., 2021). It is able to identify scenarios that can potentially originate from malicious manipulations, which may lead to major events. PHAROS exploits a HAZOP-like approach. The analysis is carried out by a team of experts (process, plant system, control, loss prevention and security experts). The method supports the identification of: the specific set of manipulations that may lead to major events; the protection requirements for the safeguards in place; and the design of the network system segmentation (Iaiani et al., 2021). This procedure is an example of the integration of safety and security expertise in the management of risk. It applies a systematic risk identification procedure that is typical of safety (HAZOP) from the domain of cyber-security threats to physical process systems. A similar approach to security and safety may lead to effective interdisciplinary communication and thus to more integrated management of safety and security risks. This is the way in which conflicts or inconsistencies between the safety and security assessment could be avoided, and it may allow the recognition of risks that could otherwise be overlooked (Ylönen et al., 2022).

## **INTEGRATED SAFETY AND SECURITY MANAGEMENT SYSTEM**

The Integrated Safety and Security Management System (IMSS) would be able to create integrated safety and security culture through its policy, motivation, training, communication, planning and control. This would lead to the establishment of positive safety and security climate and, through the simple promotion of the values, increase employees' awareness of safety and security in all systems that refer to safety, security and protection. Without this integrated approach, all those systems would be substantially fragmented.

### **Basic elements of the IMSS**

As well as with the Safety and Security Management Systems, the basic elements of the IMSS are philosophy, policy, procedures and processes. Philosophy is the first and core element, which reflects the attitude and knowledge about safety and security threats and risks. This attitude influences the implementation of standards and the affirmation that safety and security are in the domain of every employee. Policy defines the way in which the goals are to be achieved. It implies a clear definition of responsibilities and authorities, the development of processes and structures in order to incorporate safety and security goals into each aspect of organization's activities, as well as the development of skills and knowledge that are necessary for best work practices. Procedures reflect what the management expects from employees and what it wants to be done in order to allow for policies to be implemented. Procedures must contain clear instructions to all employees, planning, organizing, and control resources, as well as monitoring and assessment of safety and security state and processes. Processes refer to actual situations in a workplace. If those processes are well designed and in place, they ensure that effective procedures are well accepted and that there is no unwanted and unplanned alteration to them (Radojević, 2012).

Organizational structures and activities that comprise the IMSS may be found throughout the organization. Each employee contributes to safety and security. In large organizations, activities of this system should be more visible in some units than in others, but the system itself should be integrated into everyday activities and processes. This is achieved through implementation and support of the integrated safety and security policy, which leads to well-established procedures.

Implementation of the IMSS depends on top management initiatives. Those initiatives are not always successful. The basic element that contributes to their failure is the lack of commitment, understanding and competences. These aspects influence the success of any management system, including the IMSS. Commitment means that managers are the ones who have to insist on the effective implementation of the IMSS principles. Understanding is related to managers' knowledge and acceptance of the nature and principles

that are related to the management of safety and security. Competences reflect adequacy, adoption and implementation of policy and procedures at all levels of the organization.

There are many standards that influence the design of the IMSS, such as Seveso III directive (2012/18/EU), ISO standards, etc. (Radojević, 2012). The idea behind the IMSS is the possibility to integrate all those standards. It seems complicated and, according to some authors, nearly impossible in practice (Brooks and Coole, 2020). Nevertheless, it should be borne in mind that many organizations have already implemented standards related to management systems. Integration of the systems that are based on the same management principles, at least in theory, should be done with very little additional effort (Radojević, 2012; Ylönen et al., 2022). Benefits of the IMSS are reflected in the fact that all those issues would be managed from one centre, which would allow top managers to have complete oversight of safety and security. Reports would be integrated and sublimated, and the picture of overall safety and security would be clearer. This would, in turn, simplify decision-making. As previously mentioned, this would also be a cost-effective and comprehensive way to get an insight into all possible events that could endanger the existence and/or normal functions of an organization.

### **Possible model for the IMSS**

A model for the IMSS could be structured using the Structured Analysis and Design Technique (SADT). In this model, an IMSS could be viewed through three levels of activities (Hale et al., 1997). The levels are compatible with the classic view of management through policy, planning, control and execution. The three levels are: (1) structural, (2) planning, organizing and procedure, and (3) execution.

At the *execution level*, everyday activities may cause problems, such as failures and threats, which need to be solved. First and foremost, attention is given to problems that are already familiar and for which there are well-established procedures for elimination, reduction or control. There is not much freedom at this level. Feedback and correction cycles deal with corrections of established procedures and efforts to maintain the agreed-upon standards. When the existing norms are not adequate for the situation, there is a signal for a higher level to react.

The *planning, organizing and procedure level* involves the design and formalization of the activities for the executive level. These processes depend on a wide range of expected problems. This level is described in many security and safety guidelines. It comprises responsibilities, procedures, communication channels, etc. It contains a collection of best practices and practical recommendations and solutions for the executive level. This is the way to ensure continuity in the IMSS. The activities at this level can lead to changes at the executive level, but the changes cannot fall outside the overall philosophy and style that are developed at the structural level. This level is a bridge



between abstract principles and distribution and implementation of real everyday tasks and processes. The level requires being well-informed and prepared for new problems that may emerge. According to the new situations, this level also involves the development of new procedures or change of the existing ones in order to be effective for new risks, threats and other issues. Thus, this level has to be connected to the improvement cycle, which is necessary in all management systems. When there is a problem at this level, it is a sign that a lower level does not function well enough, that there is a signal from a higher level to make some changes, or that there are new standards or new problems in the environment. This phase includes a range of tools that are available from science, reviews and statistics on emergencies (problem acknowledgment), cost-benefit analysis (choosing a solution), control and monitoring and first aid assistance (emergency planning).

The *structural level* deals with the basic principles of the IMSS. These principles reflect the way of design, maintenance and functions of the IMSS. This is the framework and the principles that may facilitate the adoption of the IMSS by an organization. This level recognizes a problem when an organization assumes that the existing planning level is not doing its work in a satisfactory way, or that there is a need to improve or change something in order to resolve an issue. It is the meta-level, and it enables the monitoring of the IMSS activities. It also enables continuous improvements and maintenance of the IMSS. Activation of this level depends on the emergence of various dangerous situations, inadequate control report, inadequate competition, etc.

The three levels are abstract, but they are not considered independent of managerial hierarchy. Activities that are assigned to each abstract level could be allocated in many ways. For example, a security service may receive a task to design procedures, autonomous working groups can have their own safety management systems that are independent to a certain extent, the IMSS could be specified by the top management, external consultants or managers at higher levels can make routine inspections and revisions, etc. But the way in which the allocation of activities is done depends on the culture and methods of each distinct organization.

The proposed framework offers some kind of instructions in which the IMSS could be structured and activated. It is a relatively abstract framework. It does not prescribe distinct solutions but rather a general path for problem-solving. The main characteristic of the proposed model is the flow of information and resources, which implies that there should be some channels, but that there is enough freedom for an organization to choose and formulate those channels. It proposes that criteria for the assessment should be established and that the criteria should be consistent among all the levels, but the specification of the criteria is an organization's responsibility. The differences in the manner of implementation of this framework

depend on the safety and security culture of each organization.

## CONCLUSION

There is still no standard for Integrated Safety and Security Management. However, Safety and Security Management Systems fall into the category of Management Systems, which means that they should be organized according to the same basic management principles and through similar generic processes. This makes it even more reasonable to merge them and to manage them from one integrated corporate centre, which is especially important for big corporations, in which safety and security are imperative for their survival. Basic work processes are very complex for such organizations, and handling safety and security separately only creates an additional problem on top of other everyday issues. The integration of safety and security would make it easier for the top management of those organizations to handle safety and security issues.

This does not mean that safety, physical security and cyber-security should become obsolete. On the contrary, it should be emphasized that each subsystem in the IMSS is complex and independent in itself. However, considered together, they represent one entity, which has the purpose to achieve as much organizational safety and security as possible. Also, the integration has a synergetic effect on the overall safety and security of an organization, because it enables integrative and comprehensive risk assessment.

The IMSS reflects an organization's commitment to safety and security and represents a factor that adds to employees' understanding of how important safety and security are for the organization. Nevertheless, there is still little effort to achieve integration in practice, which is something that warrants a debate in all relevant fields in the near future. In order to achieve the best possible effects of integration, a new perspective should be adopted.

Finally, it should be noted that there are problems in viewing and defining SMSs and SeMSs alone, in different industries, which makes the efforts toward integration even more difficult. Some aspects that still need to be clarified are those concerning integrated methods of risk analysis, clear definitions of what constitutes safety, physical-security and cyber-security, and determination of the risks that fall within the 'blurred areas', as well as clear understanding of the benefits and drawbacks that the integration brings to the whole organization. In this author's opinion, those 'blurred areas' of safety and security risks are more present today than ever before, and the IMSS is probably the best way to deal with them.

## REFERENCES

- Bieder, C. (2021). 'Safety science: a situated science: an exploration through the lens of safety management systems', *Safety Science*, 135, 105063.

- Blokland, P.J. and Reniers, G.L. (2020). 'The Concepts of Risk, Safety, and Security: A Fundamental Exploration and Understanding of Similarities and Differences', in Bieder, C. and Pettersen Gould, K. (eds.) *The coupling of safety and security: exploring interrelations in theory and practice*. Cham: Springer, pp. 9-16.
- Brooks, D.J. and Coole, M. (2020). 'Divergence of Safety and Security', in Bieder, C. and Pettersen Gould, K. (eds.) *The coupling of safety and security: exploring interrelations in theory and practice*. Cham: Springer, pp. 63-74.
- De Maggio, M.C., Mastrapasqua, M., Tesei, M., Chittaro, A. and Setola, R. (2019). 'How to improve the security awareness in complex organizations', *European Journal Security Research*, 4(1), pp. 33-49.
- Gilligan, J.M. (2021). 'Expertise across disciplines: establishing common ground in interdisciplinary disaster research teams', *Risk Analysis*, 41(7), pp. 1171-1177.
- Hale, A.R., Heming, B.H.J., Catfhey, J. and Kirwan, B. (1997). 'Modelling of safety management systems', *Safety Science*, 26(1/2), pp. 121-140.
- Harvey, C. and Stanton, N.A. (2014). 'Safety in system-of-systems: ten key challenges', *Safety Science*, 70, pp. 358-366.
- Iaiani, M., Tugnoli, A., Bonvicini, S. and Cozzani, V. (2021). 'Major accidents triggered by malicious manipulations of the control system in process facilities', *Safety Science*, 134, 105043.
- Jore, S.H. (2020). 'Security and Safety Culture—Dual or Distinct Phenomena?', in Bieder, C. and Pettersen Gould, K. (eds.) *The coupling of safety and security: exploring interrelations in theory and practice*. Cham: Springer, pp. 43-51.
- Jørgensen, T.H., Remmen, A. and Mellado, M.D. (2006). 'Integrated management systems – three different levels of integration', *Journal of Cleaner Production*, 14(8), pp. 713-722.
- Karanikas, N., Weber, D., Bruschi, K. and Brown, S. (2022). 'Identification of systems thinking aspects in ISO 45001:2018 on occupational health & safety management', *Safety Science*, 148, 105671.
- Larsen, C.I. and Østensjø, C. (2015). *Operatørselskapene i petroleumssektoren sitt syn på sikringskultur: Bruk eller ikke bruk av begrepet sikringskultur*. Master thesis. University of Stavanger.
- Leveson, N. (2020). 'Safety and Security Are Two Sides of the Same Coin', in Bieder, C. and Pettersen Gould, K. (eds.) *The coupling of safety and security: exploring interrelations in theory and practice*. Cham: Springer, pp. 17-27.
- Li, Y. and Guldenmund, F.W. (2018). 'Safety management systems: A broad overview of the literature', *Safety Science*, 103, pp. 94-123.
- Malcolmson, J. (2019). 'What is security culture? Does it differ in content from general organizational culture?', *The 43rd Annual 2009 International Carnahan Conference on Security Technology, IEEE, 2009*, pp. 361-366.
- Matteini, A., Argenti, F., Salzano, E. and Cozzani, V. (2019). 'A comparative analysis of security risk assessment methodologies for the chemical industry', *Reliability Engineering and System Safety*, 191, 106083.
- Pettersen Gould, K. and Bieder, C. (2020). 'Safety and Security: The Challenges of Bringing Them Together', in Bieder, C. and Pettersen Gould, K. (eds.) *The coupling of safety and security: exploring interrelations in theory and practice*. Cham: Springer, pp. 1-8.
- Radojević, K. (2012). *An effectiveness and efficacy assessment model for safety and security management*. Doctoral dissertation. University of Belgrade, Faculty of security studies.
- UK Civil Aviation Authority (UKCAA). (2021). *Security management system (SeMS)*, Department for transport, [online], available: <https://www.caa.co.uk/commercial-industry/security/security-management-systems/security-management-systems/> [Accessed 10 July 2022].
- Van Brabant, K. (2001). *Mainstreaming the organizational management of safety and security. A review of aid agency practices and a guide for management*, HPG Report 9, 2001. London: Overseas Development Institute.
- Whyte, A. (2021). 'Security culture and SeMS', *Aviation Security Update, November 2021*, [online], available: <https://blog.butterfly-training.net/security-culture-and-sems/> [Accessed 05 July 2022].
- Will, M. (2020). *An Operations Guide to Safety and Environmental Management Systems (SEMS): Making Sense of BSEE SEMS Regulations*, Cambridge: Elsevier Inc.
- Ylönen, M., Tugnoli, A., Oliva, G., Heikkil, J., Nissil, M., Iaiani, M., Cozzani, V., Setola, R., Assenza, G., van der Beek, D., Steijn, W., Gotcheva, N. and Del Prete, E. (2022). 'Integrated management of safety and security in Seveso sites - sociotechnical perspectives', *Safety Science*, 151, 105741.
- Živković, S. and Palačić, D. (2015). *Upravljanje bezbednošću u poslovnim organizacijama u Srbiji i Hrvatskoj – komparativna analiza*, Niš: University of Niš – Faculty of Occupational Safety.

## ACKNOWLEDGEMENTS

This paper is a part of the Scientific Research Plan of the Faculty of security studies – University of Belgrade which is supported by the Ministry of Education, Science and Technological Development of the Republic of Serbia.

## BIOGRAPHY of the author

**Kristina Radojevic** was born in Bijelo Polje, Montenegro, in 1977. She received a diploma in organizational sciences - management from the University of Belgrade – Faculty of Organizational Sciences, and a Ph.D. degree in security studies from the University of Belgrade, Faculty of Security Studies.



Her main areas of research include management, security and safety.

She is currently working as an Assistant Professor at the Faculty of Security Studies in Belgrade, University of Belgrade.

ALEKSANDER JANEŠ<sup>1</sup>  
LJILJANA BIBIČ<sup>2</sup>  
MIRKO MARKIČ<sup>3</sup>

<sup>1,2,3</sup> University of Primorska,  
Faculty of Management

<sup>1</sup>aleksander.janes@fm-kp.si  
<sup>2</sup>bibic.lili@gmail.com

<sup>3</sup>mirko.markic@guest.arnes.si

## OVERCOMING BARRIERS – WORKPLACE SAFETY OF PERSONS WITH DISABILITIES

**Abstract:** *The aim of this paper is to identify critical areas in which measures to overcome barriers to disabilities in the workplace are most needed. Despite the increasing level of their formal employment status, the work inclusion of persons with disabilities (PWD) still poses a significant societal and workplace safety challenge. A survey among members of associations of disabled workers and employees of companies for the disabled was performed and 180 respondents completed the questionnaires. Hypotheses were tested using statistical methods such as t-test and ANOVA. This study is significant because it offers findings that will help policy makers, CEOs, entrepreneurs, and human resource managers to identify the job-related difficulties and develop policies and practices to provide a better and safer work environment to integrate PWD.*

**Key words:** barrier types, persons with disabilities, safety management, Slovenia.

### INTRODUCTION

Approximately 15%, or more than a billion people in the world, have some form of disability (Hästbacka et al., 2016). There are about 40 million PWD in Europe, between 43% and 54% of whom are able to work. Disability in Europe is reported by about one in eight people of working age (Jones, 2016; Suresh and Dyaram, 2020).

Globally, about 80% of PWD are able to work, but their rights to decent work are often limited, either at the level of employment or at the level of performing and retaining work due to various barriers (e.g. physical, social, and informational) in the work environment. The latter prevents them from having the same opportunities as other employees and prevents their work potentials from being properly exploited (Baumgärtner et al., 2014; Dong et al., 2017; Jones, 2016; Lyubykh et al., 2021).

In Slovenia, there is no official data on the number of disabled persons and estimates are given based on entries in the registers. Some estimates assume that the share of PWD among the population is around 12-13%, which is slightly less than in other European countries (15%). Disabled persons include disabled workers, children and adolescents with special needs, military and war invalids, and moderately, severely mentally, and severely physically handicapped persons (SURs, 2014). Slovenia was among the first to ratify the United Nations International Convention on the Rights of PWD (CRPD), based on which it adopted additional measures to promote social awareness and designed projects [8] to combat stereotypes, prejudices, and harmful practices. Nowadays, about 4% of all

employees in Slovenia are disabled, which is a low percentage but still much higher than in the past and in some other countries (SURs, 2014). Employment rates for PWD are very low, and empirical evidence has suggested that PWD face potential prejudice at all stages of the recruitment cycle (Lyubykh et al., 2021). In the current development phase, measures in the field of employment and work of PWD are mainly focused on employment and job retention, and less on the management or removal of barriers to work.

### LITERATURE REVIEW

Impairment is a basic health measure, which identifies reduced functional capability arising from a long-lasting illness or condition. Disability refers to functional limitations resulting from ill health or impairment if they substantially and adversely affect activities of day-to-day living and the amount or the type of work that might be undertaken (Jones, 2016).

Disability is conceptualized as arising out of the complex interaction between a health condition or impairment, barriers in the physical and social environment, and personal factors. Employers are concerned that full employment of PWD is more expensive due to the necessary adjustments to skills, jobs, and work-safety environments, and training costs and higher healthcare expenses (Stone and Colella, 1996).

Safety of the individual is an important consideration. A blind person cannot be given a job that involves handling hazardous materials. Safety should not be compromised and such workers should not endanger themselves or others. Therefore, due care is taken to

ensure that the type of disability is compatible with the nature of the job. The potential hazards associated with the job role are evaluated – hence, most employers seem to weigh the nature of the job against the safety aspects in their recruitment decisions. This may mean that perceived incompatibility between the nature of the job and the type of disability results in selective inclusion of persons with some types of disability and exclusion of others. While issues are specific to the nature and size of the organization and not generalizable, they reflect the ground reality of most medium and small-sized organizations in their efforts to be inclusive. Based on industry success stories, this certainly seems to influence the way organizations adopt inclusive best practices for employing personnel with certain types of disability. Findings of Stone and Colella (Stone and Colella, 1996) highlight how the organizational determinants are perceived as favourable for the inclusion of some PWD while excluding others.

Contrary to these notions, many companies find that the cost of adapting the work environment to PWD often outweighs inputs due to secondary positive effects. Investing in systems and equipment that enable PWD to be fully integrated into the work environment is not just a privilege for a minority of PWD, but an investment for the benefit of the entire organization, families, and society. Having a PWD on the team can provide new perspectives, leading to innovation because of different perspectives on the business and different business solutions. It seems that PWD look at life in a different way, have a strong work ethic, and exert a positive effect on team morale.

Namely, differences and heterogeneous working groups can help develop better working solutions and achieve better business results. Many companies find that employing PWD makes it easier to understand and provide better services to customers. Adapting services to the different needs of PWD enables companies to develop greater flexibility, build a reputation, achieve greater market share and higher levels of quality, integrate the inclusion of PWD, and exploit their full potential (Anand and Sevak, 2017). Employees with different types of disabilities face different types of barriers in different work environments, as follows:

- Sensory impairment usually results from an employee's vision or hearing problems that can occur at different intensities (Dong et al., 2017).
- Cognitive impairment refers to barriers to data processing that may result from mental disorders. The literature review illustrates that psychiatric disability is the most stigmatized (Stone and Colella, 1996; Lyubikh et al., 2021).
- Physical impairment is defined as a category of disability that includes barriers due to various types of physical disabilities of the employee.
- Other types of impairments relate to residual health conditions that may affect an employee's ability or limitations to work.

From the environmental perspective, there are physical, informational, and social barriers. More research is

needed on how to create sensitization training in the workplace for all employees (Kulkarni et al., 2018; Syma, 2019).

Research on PWD is extremely limited (Stone and Colella, 1996), particularly on working women who often face double discrimination: because of gender and because of disability. In the existing literature, it is clearly stated that there is a research gap in examining the work-life of PWD (Pellicena et al., 2020).

## HYPOTHESES AND METHODOLOGY

Based on the aim and literature review, we developed the following hypotheses:

H1: The type of disability is statistically significantly related to the frequency of barriers in the workplace that persons with disabilities face.

H2: Lower-educated disabled persons are more likely to face barriers in the workplace than higher-educated disabled persons.

H3: Older disabled employees are more likely to face informational barriers in the workplace than younger disabled employees.

Data collection was conducted using a multiple-choice questions survey questionnaire of our own design. In addition to demographic data, the questionnaire included respondents' assessments of encountering different types of disabilities and different physical, informational, and social barriers in the workplace. Survey questionnaire reliability (Cronbach's Alpha) was confirmed with a value of 0.894 for disability types and 0.919 for barrier types.

Data collection took place electronically from 12 April to 19 May, 2021. The electronic survey questionnaire was created using the 1KA online tool. Prior to the survey, we conducted tests on a sample of 20 people to determine their understanding of the questionnaire, the average time to complete it, and their compliance with the questions. The link to the questionnaire with a request to participate was sent to 69 associations via the Association of Disabled Workers of Slovenia (ADWS) with 49,654 members, of whom 35,413 are disabled. Due to the unexpectedly small response of the selected population, we included employees in 110 companies for the disabled. A total of 180 valid surveys were answered and included both sexes relatively evenly represented in the sample, with 46% women and 54% men. The collected data were edited in MS Excel and analysed using the IBM SPSS statistical program.

## EMPIRICAL FINDINGS

Appropriate measures to overcome barriers to PWD in the workplace can be designed through identification of critical points and areas and examination of the factors that affect them. With these assumptions, we conducted a survey among members of associations of PWD and employees of companies for PWD, from which we synthesized cross-sectional information on the current state of the barriers faced by Slovenian PWD in the workplace. Due to spatial constraints, only the most important survey results are presented.

**The impact of disability type on the frequency of barriers in the workplace**

To test hypothesis H1, we used a t-test for two independent samples after confirming normal data distribution. The hypothesis is tested with the variable type of disability (sensory, cognitive, physical) and the average estimate of the barrier's frequency perception encountered in the workplace. The results of t-tests confirm the dependence between sensory disability and the frequency of physical, informational, and social barriers that respondents face in the workplace. The average values of frequency estimates of different barrier types are statistically significantly higher among respondents with sensory disabilities than among respondents without sensory disabilities (Table 1).

**Table 1.** *Dependence between sensory disability and the frequency of encountering barriers*

Barriers	Sensory dis.	N	Mean	Diff.	Sig.
Physical	No	46	1.61	0.62	0.044*
	Yes	134	2.23		
Informational	No	46	1.46	0.93	0.001*
	Yes	134	2.39		
Social	No	46	1.45	0.56	0.017*
	Yes	134	2.01		

Note: \* 95% Confidence Interval of the Difference showed that Lower and Upper values do not cross "0" and that there is a difference between variances.  $\alpha=0.05$

The results of the analysis confirm the dependence between cognitive disability and the frequency of physical, information, and social barriers that respondents face in the workplace. Average values of frequency estimates of different barrier types are significantly higher among respondents with cognitive disabilities than among respondents without cognitive disabilities (Table 2).

**Table 2.** *Dependence between cognitive disability and the frequency of encountering barriers*

Barriers	Cognitive dis.	N	Mean	Diff.	Sig.
Physical	No	49	1.52	0.75	0.006*
	Yes	131	2.27		
Informational	No	49	1.40	1.03	0.003*
	Yes	131	2.43		
Social	No	49	1.47	0.55	0.013*
	Yes	131	2.02		

Note: \* 95% Confidence Interval of the Difference showed that Lower and Upper values do not cross "0" and that there is a difference between variances.  $\alpha=0.05$

The analysis confirms the dependence between physical disability and the frequency of physical, informational, and social barriers that respondents encounter in the workplace. Average values of frequency estimates of different barrier types are significantly higher among respondents with physical disabilities than among respondents without it (Table 3).

**Table 3.** *Dependence between physical disability and the frequency of encountering barriers*

Barriers	Physical dis.	N	Mean	Diff.	Sig.
Physical	No	46	1.42	0.87	0.000*
	Yes	134	2.29		
Informational	No	46	1.63	0.7	0.205*
	Yes	134	2.33		
Social	No	46	1.45	0.56	0.042*
	Yes	134	2.01		

Note: \* 95% Confidence Interval of the Difference showed that Lower and Upper values do not cross "0" and that there is a difference between variances.  $\alpha=0.05$

A comparison of differences in arithmetic means shows that sensory and cognitive disabilities have the smallest differences in the frequency of social barriers and the largest differences in informational barriers, while physical disabilities have the largest differences in physical barriers (Tables 1,2,3). Differences in social barriers are the least dependent on the type of disability, which means that respondents with different types of disabilities face social barriers to a similar extent. The frequency of encountering informational barriers, which relate mainly to access to various forms of information and successful communication, is primarily conditioned by sensory and cognitive disabilities, which were expected to a degree.

The dependence of different forms of disability on the barriers' frequency is also confirmed through a comparison of the means of the average frequency estimates of all encountered barriers according to the type of disability (ANOVA) and correlation coefficients between different types of disability with the frequency of encountered barriers. Coping with different types of barriers is most strongly influenced by physical disability, followed by cognitive and sensory disability (Table 4).

**Table 4.** *F statistics (ANOVA) and correlations between disability type and barrier frequency*

Disability	F	Sig.	Corr.	Sig.
Sensory	28.72	0.000	0.480**	0.000
Cognitive	32.74	0.000	0.512**	0.000
Physical	34.06	0.000	0.518**	0.000

Note: \*\*. Correlation is significant at the 0.01 level (2-tailed).

Testing of hypothesis H1, that the type of disability is statistically significantly related to the frequency of workplace barriers faced by PWD, showed that hypothesis H1 cannot be rejected.

**The impact of education level on the frequency of barriers in the workplace**

Verification of H2 was performed using the analysis of variance (ANOVA) and the variables *education level* and *assessment of perceived barriers in the workplace*. We performed the analysis with all levels of education



(1 to 6). ANOVA showed that there were no statistically significant differences between the perception of the barrier type and the education level (Table 5).

The correlations of the analysis between the barriers type and the level of education are weak and are not statistically significant in the case of informational and social barriers. Statistically, significant correlations are physical barriers and barriers in general.

**Table 5.** *F statistics (ANOVA) and correlations between barrier type and education level*

Barriers	F	Sig.	Corr.1	Sig.1
General	2.15	0.062	-0.161*	0.030
Physical	2.08	0.070	-0.154*	0.039
Informational	1.81	0.113	-0.134	0.072
Social	1.11	0.356	-0.135	0.071

Note: \*. Correlation is significant at the 0.05 level (2-tailed).

Based on the results of the analyses, we found that there are no statistically significant differences between the perception of barriers and the level of education, so hypothesis H2 can be rejected. The differences are not statistically significant probably because most of the participating respondents are regularly employed in companies for the disabled (59%), which improves the working conditions of employees.

**Influence of age on the frequency of informational barriers in the workplace**

To test the third hypothesis, we used the t-test for two independent samples (older and younger employed disabled people). The hypothesis was tested using the variables of age and the assessment of perceived barriers that respondents face in the workplace. The survey analysis partly confirms that older PWD is more likely to encounter informational barriers and that the difference in the frequency of encounters with informational barriers between age groups is greater than the differences in the frequency of physical and social barriers. The results show that informational barriers (Means diff.=0,21) are age-dependent to a certain extent but cannot be generalized to the population, because we found that there were no statistically significant differences between them (Table 6).

**Table 6.** *Influence of age on the frequency of informational barriers*

Barriers	Age group	N	Mean	Diff.	Sig.
Physical	Old.	123	2.10	0.1	0.156
	Yng.	57	2.00		
Informational	Old.	123	2.22	0.21	0.259
	Yng.	57	2.01		
Social	Old.	123	1.89	0.08	0.892
	Yng.	57	1.81		

Note: \* 95% Confidence Interval of the Difference showed that Lower and Upper values cross “0” and that there is no difference between variances.  $\alpha=0.05$

The correlation coefficients between barrier types in the workplace and age have weak correlations, which are not statistically significant. The results showed that the differences are not statistically significant, which could be due to most respondents being employed in companies for the disabled (59%) and thus being better informed, i.e. there are no differences between age groups in terms of informational barriers. Another reason could be that a large share of the ADWS’s older members does not use e-mail and that the data on members was incomplete. Therefore, Hypothesis H3 can be rejected.

**Discussion**

The aim of this paper was to identify critical areas in which measures to overcome barriers to disabilities in the workplace are most needed. Among the various types of barriers, the most problematic are the informational barriers, followed by the physical and social barriers.

Regarding the informational barriers, the respondents most often encounter a lack of information on changes and innovations in work processes, followed by limited access to information on work requirements and expectations and poor communication with superiors, colleagues, and users. Some of the rarest informational barriers include access to assistance due to communication problems and access to data and materials needed for work. These findings can be related to the studies by Laaksonen et al., 2017 and Mithout, 2021, which state that younger employees are often better informed and have access to current data on opportunities, rights, and responsibilities. Therefore, policies focusing only on access to employment are no longer sufficient, in a context where qualified disabled workers feel growingly able to voice their frustrations and aspire not only to “a job” but also to work satisfaction (Harb and Sidani, 2022; Mithout, 2021).

Regarding the physical barriers, the respondents indicated stairs as the most problematic. Other relatively common physical barriers include poor acoustics or noise, poor lighting, narrow passages and small spaces, and non-adapted work equipment. The respondents also pointed out the inadequacy of communication devices, curbs, and inadequate placement of objects as the least problematic. Regarding different types of disabilities and barriers in the workplace, Padkapayeva et al., (2017) found that organizations have a wide range of options to address physical, informational (Harb and Sidani, 2022), and social barriers to the successful integration of employees with sensory, cognitive, and physical disabilities.

Regarding the social barriers, which the respondents estimated as the least problematic, incorrect assumptions about their disability and the view of their disability as a tragedy are the most common. Narayanan (2018) confirms that disabled employees in

the workplace face several different barriers and that they experience discrimination in the work environment due to a lack of adaptation. Among the most common are physical barriers and inaccessibility of premises, lack of appropriate support technology, and negative attitudes of people towards disability (Csillag et al., 2019).

The average assessments of the respondents indicate the presence of different practices to overcome barriers in the workplace. Some of the most common practices observed by the respondents include employers allowing a certain degree of flexibility during working hours, e.g. part-time work, late start and early finish, and part-time or full-time teleworking. Relatively often, the layout of the workplace premises, furniture, and equipment is adapted to disabilities, and employers invest in the purchase and adaptation of work equipment that makes it easier for the respondents to work (Nagymáté, 2012). The respondents are less likely to be assigned jobs that are easier for them to perform, to receive additional training, mentoring, supervision or support because of their disabilities, or to be reassigned to smaller jobs that are difficult for them to perform.

Research on the factors of different barrier types shows that barrier frequency faced by PWD in the workplace is influenced by the disability type (Pellicena et al., 2020). On the other hand, education level and age are only partly recognized as factors of barrier frequency, but neither is statistically significant (Ta and Khoo, 2013). The impact of education (Jones, 2016) and age on the frequency of informational barriers in the workplace has been identified by several authors (Morash-Macneil et al., 2018; Bengtsson and Datta Gupta, 2017). Csillag et al. (Csillag et al., 2019) confirm that disabled people with lower education are more likely to face barriers in the workplace (Anand and Sevak, 2017). Bengtsson and Datta Gupta (Bengtsson and Datta Gupta, 2017), however, explain that the correlation may be due to the specifics of the jobs in which lower-skilled workers are employed, but may also be due to attitudes towards the lower-educated social group.

However, companies can capitalize on the skills of PWD only if they provide them with the required conditions allowing them to perform to the best of their abilities. Moreover, demonstrating good job performance is extremely important for long-term inclusion, since employers may otherwise assume that PWD are a poor investment and will not consider this demographic group for future positions (Stone and Colella, 1996; Baumgärtner et al., 2014). The most important organizational adjustment in addition to the adoption of specific policies and programmes includes a change in employee attitudes, sensitization, social climate, and organizational culture, which are critical factors of successful and effective practices. Many authors argue that organizations have a responsibility to the community within which they operate and need to develop approaches that embrace diversity (Kulkarni et al., 2018; Syma, 2019).

## CONCLUSION

Despite the slowly increasing level of their formal employment status, the inclusion of PWD in the social community still poses significant challenges. The aim of this research was to identify critical areas where measures to overcome barriers to disability in the workplace are most needed.

Hypothesis H1 test showed that the type of disability is statistically significantly related to the perceived barrier frequency in the workplace.

Regarding hypothesis H2, we found that among the less educated PWD compared to the higher educated PWD there were no statistically significant differences in the perception of the types of barriers in the workplace.

When testing hypothesis H3, we concluded that there were no statistically significant differences in the perception of informational barriers between older and younger employed PWD, even though the differences between the averages were the highest in the older PWD group.

Due to the differences between the barrier types and their impact on perceiving barrier frequency in the workplace, it is essential that each organization develop measures tailored to its own employees and work environment. The findings of this study can greatly help policymakers, CEOs, entrepreneurs, and human resource managers to identify job-related difficulties and develop policies and safety practices to alleviate them in order to provide a better work environment for PWD integration.

The limitation of the research is reflected in the small response to the survey, which is due to the small share of employed members of the ADWS, a large share of older members who do not use e-mail, and incomplete data on the members. Further research should encompass a larger respondent sample. The recommendation is to interview members of associations of disabled workers and employers from companies for disabled people and to present their points of view. In this way, it is possible to shed light on the position of disabled employees and improve the working conditions and the long-term employment opportunities for PWD who are able and willing to work. Therefore, this study should be complemented with more detailed studies on specific situations about differences between employed PWD. Further research is necessary to understand the generalizability of the disability stereotypes reinforced by employers and to learn what impact this might have on the workplace safety, inclusion, and job retention of PWD.

Klarsfeld et al., (2019) argue that disability cannot be interpreted uniformly across different cultures, so the significance of the cultural context should be researched and considered. The career development of PWD is a social phenomenon that can depend on factors beyond regulatory compliances (Csillag et al., 2019). Increased opportunities for the employer and the employee to co-create and co-craft workplace expectations can result in positive outcomes. Employers may benefit from knowledge regarding the

types of support that are valued by employees with disabilities, and utilization of this knowledge can subsequently lead to higher rates of job retention, employee job satisfaction, and, in the long term, creation of a supportive organizational culture (Sundar et al., 2018).

Inclusion can be achieved through sensitization training, wherein both PWD and other organizational members can understand each other's needs, expectations, and styles of safe work (Kulkarni et al., 2018).

## REFERENCES

Anand, P. and Sevak, P. (2017). 'The role of workplace accommodations in the employment of people with disabilities', *Journal of labor policy*, 6(1), pp. 1-20.

Baumgärtner, M.K., Böhm, S.A. and Dwertmann, D.J.G. (2014). 'Job performance of employees with disabilities: Interpersonal and intrapersonal resources matter', *Equality, Diversity and Inclusion*, 33(4), pp. 347-360.

Bengtsson, S. and Datta Gupta, N. (2017). 'Identifying the effects of education on the ability to cope with a disability among individuals with disabilities', *PLoS One*, 12(3), pp. 173-186.

Csillag, S., Gyori, Z. and Svastics, C. (2019). 'Long and winding road?', *Journal of Enterprising Communities: People and Places in the Global Economy*, 13(½), pp. 42-63.

Dong, S., Warner, A., Mamboleo, G., Guerette, A. and Zegarra Zalles, M. (2017). 'Barriers in accommodation process among individuals with visual impairments', *Journal of rehabilitation*, 83(2), pp. 27-34.

Hästbacka, E., Nygård, M. and Nyqvist, F. (2016). 'Barriers and facilitators to societal participation of people with disabilities', *Alter*, 10(3), pp. 201-220.

Harb, B. and Sidani, D. (2022). 'Smart technologies challenges and issues in social inclusion – case of disabled youth in a developing country', *Journal of Asia Business Studies*, 16(2), pp. 308-323. <https://doi.org/10.1108/JABS-10-2020-0389>.

Jones, M. (2016). 'Disability and labor market outcomes', *IZA world of labor*, 12(2), pp. 1-10.

Klarsfeld, A., Knappert, L., Kornau, A., Ngunjiri, F.W. and Sieben, B. (2019). 'Diversity in underresearched countries: new empirical fields challenging old theories?', *Equality, Diversity and Inclusion*, 38(7), pp. 694-707.

Kulkarni, M., Gopakumar, K.V. and Patel, S. (2018). 'How effective are disability sensitization workshops', *Employee Relations*, 40(1), pp. 58-74.

Laaksonen, M., Liukko, J., Rantala, J., Polvinen, A., Kesälä, M., Varis, J. and Kuivalainen, S. (2017). 'Workplace level differences in the risk of disability retirement', *European journal of public health*, 27(3), pp. 23-53.

Lyubykh, Z., Turner, N., Barling, J., Reich, T.C. and Batten, S. (2021). 'Employee disability disclosure and managerial prejudices in the return-to-work context', *Personnel Review*, 50(2), pp. 770-788.

Markič, M., Vedenik, L., Pavlič, M. and Mevlja, B. (2019). 'Integration of safety and health at work into project management', *Sigurnost*, 61(3), pp. 227-236.

Mithout, A-L. (2021). 'From equal access to employment to equal career opportunities', *Alter*, 15(4), pp. 341-353.

Morash-Macneil, V., Johnson, F. and Ryan, J.B. (2018). 'A systematic review of assistive technology for individuals with intellectual disability in the workplace', *Journal of special education technology*, 33(1), pp. 15-26.

Nagymáté, N. (2012). 'Labour market attributes of disabled people in Hungary', *Applied Studies in Agribusiness and Commerce*, 6(1-2), pp. 119-122.

Narayanan, S. (2018). 'A study on challenges faced by disabled people at workplace in Malaysia', *International journal on children, women, elderly and people with disabilities*, 18(2), pp. 185-197.

Padkapayeva, K., Posen, A., Yazdani, A. Buettgen, A., Mahood, Q. and Tompa, E. (2017). 'Workplace accommodations for persons with physical disabilities', *Disability and rehabilitation*, 39(21), pp. 2134-2147.

Pellicena, M.À., Ivern, I., Giné, C. and Múries, O. (2020). 'Facilitating factors for the job placement of workers with intellectual disabilities: supervisors and coworker mentors perspectives', *Advances in Mental Health and Intellectual Disabilities*, 14(6), pp. 213-227.

Stone, D. and Colella, A. (1996). 'A model of factors affecting the treatment of disabled individuals in organizations', *Academy of Management Review*, 21(2), pp. 352-401.

Sundar, V., O'Neill, J., Houtenville, A.J., Phillips, K.G., Keirns, T., Smith, A. and Katz, E.E. (2018). 'Striving to work and overcoming barriers', *Journal of Vocational Rehabilitation*, 48(1), pp. 93-109.

Suresh, V. and Dyaram, L. (2020). 'Workplace disability inclusion in India: review and directions', *Management Research Review*, 43(12), <https://doi.org/10.1108/MRR-11-2019-0479>.

SURS. (2014). *In September 2014, 15.7% of all registered unemployed persons in Slovenia were persons with disabilities*, [online] available: <https://www.stat.si/StatWeb/News/Index/4916> [Accessed 5 Jan 2020].

Syma, C. (2019). 'Invisible disabilities: perceptions and barriers to reasonable accommodations in the workplace', *Library Management*, 40(½), pp. 113-120.

Ta, T. and Khoo, S. (2013). 'Challenges faced by Malaysians with disabilities in the world of employment', *Disability*, 24(1), pp. 6-21.

## ACKNOWLEDGEMENTS

No acknowledgments.

## BIOGRAPHY of the first author

**Aleksander Janeš**, PhD, is an Associate Professor in the fields of Operations Management, Management of Quality and Business Excellence at the Faculty of Management, University of Primorska. His research work is focused on business process management. (<https://orcid.org/0000-0001-5678-0737>)

DANIJELA PROTIĆ<sup>1</sup>  
MIOMIR STANKOVIĆ<sup>2</sup>

<sup>1</sup>Center for Applied Mathematics and  
Electronics, Belgrade

<sup>2</sup>Mathematical Institute of SASA,  
Belgrade

<sup>1</sup>[danijelaprotic318@gmail.com](mailto:danijelaprotic318@gmail.com)

<sup>2</sup>[miomir.stankovic@gmail.com](mailto:miomir.stankovic@gmail.com)

## RISK MANAGEMENT: MACHINE LEARNING APPROACH TO THE COMPUTER NETWORK SECURITY

**Abstract:** *Machine learning algorithms are widely used in performing risk management because they can discover trends in high-risk systems, which are not visible at first glance. Computer network behaviour is one of the possible sources of security risks. The supervised machine learning models are proven to be accurate in the decisions on possible attacks. This paper presents the detection of anomalies in the computer network traffic based on artificial neural networks, nearest neighbour classifiers, decision trees, and support vector machines.*

**Key words:** risk management, machine learning, computer network security.

### INTRODUCTION

Most businesses today recognize the importance of securing information systems and networked infrastructures. The usage of new communication technologies has become an important component that can either boost or degrade productivity. This happens mostly due to the importance of data transfer over computer networks. As a result, strong links are being established between security and enterprise business activity. The risk management (RM) discipline incorporates a variety of architectures, strategies and models that deal with this issue. RM analytics can help in evaluating uncertain situations, the likelihood of an incident occurring based on context and any associated consequences.

The ability of a computer system to enhance its performance through data exposure without needing to follow explicitly specified instructions is known as machine learning (ML). ML offers a variety of possible benefits for use cases like risk RM and security. ML technology is exceptionally popular among academics in the field of computer networking because it offers considerable advantages for protecting critical network infrastructures. It provides real-time malware detection, improved cybersecurity measures' effectiveness and efficiency, increased true positives, improved signal-to-noise (S/N) ratios that reduce false alarms, lower operating and financial costs and provides many other benefits.

This paper is organized as follows: the first part presents the ML method for RM, while the second section discusses computer network security. The third section addresses the use of supervised learning to manage unknown computer network behaviour. The fourth chapter covers experiments with supervised ML models. The last chapter concludes the paper.

### COMPUTER NETWORK SECURITY

When a company connects its systems and computers, the difficulties of one user may affect everyone else on the network. As a result, data analytics has become increasingly important in the daily activities of many companies. Despite the various benefits of using computers, networking raises the danger of security flaws such as data loss, malicious attacks, or security breaches. There are measures that can be taken to increase network security. Computer network security is the process of implementing both physical and software preventative measures to protect the underlying communication network from unauthorized access, misuse, malfunction, modification, damage, or exposure. As a result, most companies are investing considerably in preventive measures, even though these investments might not yield the desired outcomes. When difficulties are not addressed properly, investments may fail to yield the desired outcomes. What is even worse, they may expose companies to unanticipated risks.

#### Intrusion detection systems

The recent increase in malicious attacks on sensitive data is partly due to the rapid growth of computer networks. In order to protect computer networks from various forms of harmful behavior, intrusion detection systems (IDSs) have emerged as crucial tools. IDSs belong to one of three categories: host-based (HB), network-based (NB), or hybrid. The NB IDS can further be divided into signature-based IDS and anomaly-based IDS, both of which are inspired by an adaptive human immune system (HIS) (Alyiu et al. 2020). Signature-based IDSs compare the unknown network traffic to a database of a known attack. Although they are rather quick, they are unable to identify unidentified hazardous attempts. IDSs with an

anomaly-based approach can detect changes in the computer network's typical behavior. They are capable of identifying unknown attacks, but the training process of developing a model of typical network behavior takes a lot of time and storage. When the computer network traffic is considered normal, the binary classifier assigns the new data instance to the class that is regarded as "normal". Instances of data that reveal unknown network behavior are referred to as anomalies. For this reason, ML-based binary classifiers are ideal candidates for anomaly-based intrusion detection (Marinescu et al. 2020), (Halimaa and Sundarkantham 2019). However, the major problem is the amount of training data. Multiple features in data sets with different magnitudes, ranges and units all present challenges for ML algorithms, too.

**Network intrusion detection and prevention: Machine learning approach**

Unexpected intrusions and threats that are undetectable by traditional signature-based intrusion detection systems can be detected with novel ML strategies that monitor network traffic for suspicious activity, identify malicious attacks, enable robust network protection, provide strong network security over ethernet and wireless networks and use ML-based anomaly detection capabilities for network-level threat identification and classification.

**Table 1. Machine learning models**

MACHINE LEARNING MODELS	RELATED WORK
k-NN	Li et al. (2022), Al-Imran and Ripon (2021)
SVM	Li et al. (2022), Al-Imran and Ripon (2021), Vimalkumar and Radhika (2017), Yousef et al. (2017), Xia et al. (2012), Belavagi and Munyal (2016), Belouch et al. (2018), Protic and Stankovic (2018), Peng et al. (2018)
NB	Vimalkumar and Radhika (2017), Xia et al. (2012), Belavagi and Munyal (2016), Protic and Stankovic (2018), Srivastava et al. 2020; Otham et al. (2018), Koc et al. (2012)
k-means clustering	Vimalkumar and Radhika (2017), Protic and Stankovic (2018), Natesan et al. (2017), Manzoor and Morgan (2016), Ferhat and Sevcac (2018)
DT	Li et al. (2022), Al-Imran and Ripon (2021), Vimalkumar and Radhika (2017), Belavagi and Munyal (2016), Protic and Stankovic (2018), Otham et al. (2018), Manzoor and Morgan (2016),
RF	Vimalkumar and Radhika (2017), Xia et al. (2012), Belavagi and Munyal (2016), Protic and Stankovic (2018), Srivastava et al. 2020; Otham et al. (2018)
NN	Li et al. (2022), Al-Imran and Ripon (2021), Protic and Stankovic (2018),

The following ML algorithms and models are being considered for network intrusion detection and prevention:

- k-Nearest Neighbour (k-NN),
- support vector machine (SVM),
- Naïve Bayes,
- k-means clustering,
- decision tree (DT),
- random forest (RF),
- neural networks (NN), etc.

Many researchers have investigated the use of the presented models (See Table 1). These systems can all detect and/or reject malicious network traffic to contribute to overall network security.

**MANAGING UNKNOWN COMPUTER NETWORK BEHAVIOR: SUPERVISED MACHINE LEARNING**

The two primary types of ML approaches are unsupervised ML approaches, in which models extract hidden patterns from the input data, and supervised ML techniques, in which models are developed using labelled data and reinforcement learning, in which the system interacts with a dynamic environment (Sasidhar 2020). Unsupervised learning does not provide the learning algorithm labels, enabling it to discover structure in the input on its own. Moreover, unsupervised learning can be a distinct goal in and of itself (discovering hidden patterns in data) or a means to an objective (feature learning). When a system interacts with a dynamic environment in which it must accomplish a certain task, it is referred to as reinforcement learning. In supervised learning, the system is presented with sample inputs and their desired outputs by a "teacher", while the goal is to learn the universal principle that maps inputs to desired outputs.

**Supervised machine learning models for binary classification in anomaly-based intrusion detection**

In this paper, we present the results of the experiments on four supervised ML models, used as binary classifiers in the detection of anomalies in computer network traffic, namely:

- k-NN,
- SVM,
- DT and
- feedforward NN (FNN).

One of the simplest classification models is the k-NN. The decision rule, the number of neighbours and the distance measure all affect the classifier's performance. Due to the costly test phase and strong dependence on the amount of the data, the k-NN model can be enhanced with a weighted k-NN model (wk-NN) in which instances that are closer to the new instance obtain larger weights in the decision than those which are more distant (Zhao and Chen 2016). SVM is a non-linear mapping technique that transforms a low-



dimensional data set that cannot be separated linearly into an optimal hyperplane for patterns that can be separated linearly. Patterns that are not linearly separable are extended by the transformation of the data into a linearly separable new space. The data points that are closest to the hyperplane are known as support vectors (Burgess 1998). One of the tree-like prediction algorithms, DT, uses branching to anticipate decision outcomes. Links and nodes stand in for features and the decision-making procedures, respectively (Sebastiani 2002). The FNN consists of layers with highly connected neurons in each layer, with the output layer producing the outputs that relate to the input data. The FNN is trained iteratively through modification of weights so that the inputs map an appropriate response (Protic 2015). Due to a large number of parameters the FNN should be trained with one of the fast and precise iterative algorithms, like Levenberg-Marquardt (LM), Gauss-Newton (GN), or similar (Levenberg 1944), (Marquardt 1963).

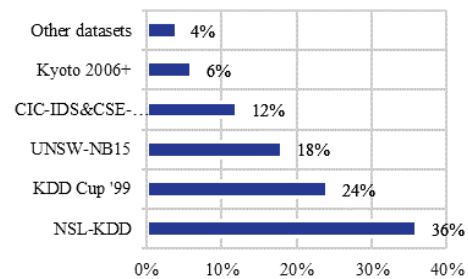
### The most widely used dataset for research on intrusion detection

Researchers use numerous datasets to evaluate ML-based models, depending on both purpose and the anticipated outcome in terms of accuracy, processing time, false positive or false negative results as well as many other factors. Table 2 lists the most widely used datasets (Protic and Stankovic 2022).

**Table 2.** The most widely used datasets

DATASET	DESCRIPTION
ADFA-LD/WF	Created from the evaluation of the system-call-based HIDS; Linux and Unix OS (LD) and Windows (WF).
AWID	WLAN traffic in packet-based format; 37 million packets in one hour captured.
CAIDA	Collected on commercial backbone link from 2008 to 2019; Does not contain a diversity of attacks.
CIC-IDS-2017	Captured over a period of 5 days; contains network traffic in packet-based and bidirectional flow-based format.
CSE-CIC-2018	10 days of network traffic and log files of 50 machines from the attacker side and 420 PCs and 30 servers from the victim organization.
ISCX 2012	7 days of packet network traffic were observed.
KDD Cup '99	Five weeks of network traffic in a packet-based format
Kyoto 2006+	3 years of real packet-based network traffic; packets converted into the sessions.
NSL-KDD	Derived from the KDD-Cup '99 dataset; does not contain redundant records in the training set nor duplicates in the test set.
UNSW-NB15	A hybrid of real modern normal activities and synthetic attack behavior. The tcpdump tool was used to capture 100 GB of raw network traffic.

Ahmad et al. (2020) found the dataset distribution as shown in Figure 1.



**Figure 1.** Distribution of the datasets

According to the findings, ~80% of all ML-based IDS research is performed on the KDD Cup '99 and NSL-KDD datasets, which are both derived from the DARPA dataset and represent simulations of real network traffic. The Kyoto 2006+ dataset is the only one that is derived from real network traffic. These are most likely the causes of such dataset distribution.

## RESULTS AND DISCUSSION

Consider the factors of anomaly-based intrusion detection from the standpoint of RM and highlight scientific research on the use of ML-based binary classifiers to determine whether the IDS identified network traffic is classified as normal or abnormal. In the area of risk management, it is essential to find useful clues in the midst of vast amounts of data containing sensitive information. Jia and Wu (2022) outline the application of ML in corporate RM and offer relevant work on RM in general. The authors classify risk as internal (operational, financial and strategic) and external (market and political). They are, however, all interconnected by computer networks and consequently network traffic. If the IDS is of the signature-based type, it can only detect specific attacks and cannot detect unknown malicious behaviour. ML-based binary classifiers can detect an anomaly, which can be a known attack too, or a version of several unknown malicious behaviours.

The accuracy of the model is the metric most often used to describe the quality of the binary classifier. The accuracy is the ratio of correctly detected instances to all instances of the data set. Table 3 lists the results of maximum accuracy for binary classifiers and the datasets taken from the articles since 2020.

**Table 3.** Accuracy of classifiers

AUTHORS	DATA SET	MODEL	ACC
Vallejo-Hunaga (2021)	UNSW-NB 15	SVM	81.5%
Siddiqui and Park (2020)	ICSX-IDS-2012	NN	99.7%
Thakkar et al. (2020)	NSL-KDD	k-NN	99.9%
Sing and Banjee (2020)	NSL-KDD	SVM	99.9%
Keserwani et al. (2021)	UNSW-NB 15	SVM	99.9%
Mishra et al. (2020)	UNSW-NB 15	SVM	99.8%
Wang et al. (2020)	UNSW-NB 15	DT	83.9%
Serkani et al. (nd)	KDD Cup '99	DT	99.9%

In this paper, we present the results of experiments conducted on a daily record of the Kyoto 2006+ dataset (Protic and Stankovic 2018), containing ~58,000 instances in total. Nine numerical features are selected for model evaluation (Count, Same\_srv\_rate, Error\_rate, Srv\_error\_rate, Dst\_host\_count, Dst\_host\_srv\_count, Dst\_host\_same\_src\_port\_rate, Dst\_host\_error\_rate, Dst\_host\_srv\_error\_rate). MATLAB Classification Learner and Neural Network Toolbox are used to evaluate the following classifiers:

- k-NN:  $k=10$ , Euclidean distance;
- wk-NN:  $k=10$ , weights determined as inverse squared distances;
- SVM: medium Gaussian;
- DT: Iterative Dichotomiser 3 (ID3) algorithm (Quinlan 1986);
- FNN: 9 inputs, 9 neurons in the hidden layer, one output neuron (9-9-1 structure); tangent hyperbolic (tanh) activation functions (Protic and Stankovic 2020);

Of all instances, 75% is used to train the models whereas 25% is used for testing. There are two data scaling methodologies technologies used: Min-Max normalization in the range  $[-1,1]$  and tanh normalization (THN), both applied to range the instances in the same fixed range. The formula for Min-Max normalization is:

$$x(i)_{[-1,1]} = \frac{x(i) - \frac{x_{max} + x_{min}}{2}}{\frac{x_{max} - x_{min}}{2}} \tag{1}$$

$x(i)_{[-1,1]}$  represents Min-Max normalized  $i$ -th instance  $x(i)$ , while  $x_{max}$  and  $x_{min}$  represent maximum and minimum of the selected feature.

The THN normalization is determined by the formula

$$x(i)_{THN} = \tanh\left(\frac{x(i) - \frac{x_{max} + x_{min}}{2}}{\frac{x_{max} - x_{min}}{2}}\right) \tag{2}$$

$x(i)_{THN}$  represents THN normalized  $i$ -th instance. The magnitudes of the feature vectors are thus binary-like and in the range  $\pm 1$  of Min-Max normalization, and  $\pm 0.76$  (i.e.  $\tanh(\pm 1)$ ) for THN normalization. The tanh function in this range is quasi-linear which, furthermore, makes training with the LM algorithm faster and more accurate, because it combines the precise but slow gradient descent (GD) algorithm with the much faster (near the optimal solution) GN algorithm (Levenberg 1944), (Marquardt 1963). Table 4 shows the results.

**Table 4.** Min-Max and THN normalization accuracy

MODEL	MIN-MAX	THN
SVM	99.2%	99.1%
DT	99.4%	99.4%
k-NN	99.4%	99.3%
wk-NN	99.6%	99.4%
FNN	99.3%	99.4%

All models are proven to be highly accurate, with an accuracy rating of 99.1%. It is also clear that when the THN is applied to non-normalized features, there is practically no improvement in model quality.

Now, consider processing time, which is the sum of time spent training and testing the models. Table 5 summarizes the results.

**Table 5.** Min-Max and THN normalization processing time

MODEL	MIN-MAX [S]	THN [S]
SVM	43.4	26.9
DT	6.3	2.5
k-NN	103.2	56.1
wk-NN	105.3	56.3
FNN	12.1	5.0

According to the findings, the THN normalization reduces processing time by more than twofold when compared to the Min-Max normalization of the nine non-normalized features. Although the models detect normal traffic and anomalies with nearly equal accuracy, THN normalization should be used when processing time is a priority.

## CONCLUSION

Based on current trends, there is still room for more research and analysis into the use of ML-based binary classification in RM. Because of the discrepancies between theory and practice, flexibly in practice should be implemented. In the future, RM should be a crucial link with intrusion detection that companies should pay attention to. This paper discusses research on binary classification improvements based on four ML-based binary classifiers' accuracy and processing time using two pre-processing strategies. All models are proven to be very accurate. However, with the THN normalization, the processing time is significantly reduced.

## REFERENCES

Ahmad, Z., Khan, A.S., Shiang, C.W., Abdulah, J. and Ahmad, F. (2020) 'Network intrusion detection system: A systematic study of machine learning and deep learning approaches', *Emerging Telecommunication Technologies*, <https://doi.org/10.1002/ett.4150>

Al-Imran, M. and Ripon, S.-H. (2021) 'An analytical assessment using deep learning and state-of-the-art machine

- learning models', *International Journal of Computational Intelligence Systems*, 14(200), <https://doi.org/10.1007/s44196-021-00047-4>
- Aliyu, F. Sheltami, T. Deriche, M. et al. (2020) 'Human Immune-Based Intrusion Detection and Prevention System for Fog Computing', *J. Netw Syst Manage*, 30, p. 11, <https://doi.org/10.1007/s10922-021-09616-6>
- Belavagi, M. and Munyal, B. (2016) 'Performance evaluation of supervised machine learning algorithms for intrusion detection', *12<sup>th</sup> International Multi-Conference on Information Processing (ICMP), Procedia Computer Science*, 89, pp. 117-123.
- Belouch, M., El Hadaj, S. and Idhammad, M. (2018) 'Performance evaluation of intrusion detection based on machine learning using Apache Spark', *Procedia Computer Science*, 127, pp. 1-6.
- Burges, M. (1998) 'Computer immunology', *12<sup>th</sup> USENIX Conference on system administration, Boston, MA, USA*, pp. 283-298.
- Ferhat, K. and Sevcan, A. (2018) 'Big data: controlling fraud by using machine learning libraries on Spark', *International Journal of Applied Mathematics and Computing*, 6(1), pp. 1-5.
- Halimaa, A. and Sundarkantham, K. (2019) 'Machine Learning Based Intrusion Detection System', *Proceedings of 3<sup>rd</sup> International Conference on Trends in Electronics and Informatics (ICOEI)*, pp. 916-920. <https://doi.org/10.1109/ICOEI.2019.8862784>
- Jia, D. and Wu, Z. (2022) 'Application of machine learning in enterprise risk management', *Security, Privacy and Trust Management in Future Smart Systems*, article ID 4323150, <https://doi.org/10.1155/2022/4323150>
- Keserwani, P.K., Govil, M.C. and Pili, E.S. (2021) 'An effective NIDS framework based on comprehensive survey of feature optimization and classification techniques', *Neural Computing and Applications*, <https://doi.org/10.1007/s00521-021-06093-5>
- Koc, L. Mazzuchi, T.A. and Sarkani, S. (2012) 'A network intrusion detection system based on a hidden Naïve Bayes Multiclass Classifier', *Expert System with Applications*, 39(18), pp. 13492-13500.
- Levenberg, K. (1944) 'A method for the solution of certain problems in least squares', *Quarterly of Applied Mathematics*, 5, pp. 164-168.
- Li, J., Qu, Y., Chao, F., Shum, H.P.H., Ho, E.S.L. and Yang, L. (nd) 'Machine learning algorithms for Network intrusion detection'. In Sikos, L. (ed.) *AI in Cybersecurity. Intelligent Systems Reference Library*, 151, Springer, Cham, [https://doi.org/10.1007/978-3-319-98842-9\\_6](https://doi.org/10.1007/978-3-319-98842-9_6)
- Li, Y., Xia, J., Zhang, S., Yan, J., Ai, X. and Dai, K. (2012) 'An efficient intrusion detection system based on support vector machines and gradually feature removal method', *Expert System with Applications*, 39(1), pp. 424-430.
- Manzoor, M.A. and Morgan, Y. (2016) 'Real-time support vector machine-based network intrusion detection system using Apache Storm', *In IEEE 7<sup>th</sup> annual information technology, electronics and mobile communication conference, Piscataway: IEEE*, pp. 1-5.
- Marinescu, M.-R., Avram, M., Voitinicu, C., Savin, M., Mihailescu, C. and Ghiculescu, L.-D. (2020) 'Electrotechnical Sensors with interdigitated electrodes counting T-cells', *Romanian Journal of Information Science and Technology*, 23(44), pp. 368-378.
- Marquardt, D. (1963) 'An algorithm for least-squares estimation of nonlinear parameters', *SIAM Journal of Applied Mathematics*, 11(2), pp. 431-441.
- Mishra, A., Cheng, A.M.K. and Zhang, Y. (2020) 'Intrusion detection using principal component analysis and support vector machines', *2020 IEEE 16<sup>th</sup> International Conference on Control and Automation*, pp. 907-912.
- Natesan, P. et al. (2017) 'Hadoop based parallel binary bat algorithm for network intrusion detection', *International Journal of Parallel Programming*, 45(5), pp. 1194-23.
- Otham, S.M., Ba-Alwi, F.M., Alsohybe, N.T. and Al-Hashida, A.Y. (2018) 'Intrusion detection model using machine learning algorithm on big data environment', *Journal of Big Data*, 5(34) <https://doi.org/10.1186/s40537-018-0145-4>
- Peng, K., Leung, V.C. and Huang, Q. (2018) 'Clustering approach based on mini match K means for intrusion detection system over big data', *IEEE Access*.
- Protic, D. (2015) 'Feedforward neural networks: The Levenberg-Marquardt optimization and optimal brain surgeon pruning', *Vojnotehnickiglasnik/Military Technical Courier*, 63(3), pp. 11-28.
- Protic, D. and Stankovic, M. (2018) 'Anomaly-Based Intrusion Detection: Feature Selection and Normalization Instance to the Machine Learning Model Accuracy', *European Journal of Engineering and Formal Sciences*, 1(3), pp. 43-48.
- Protic, D., Stankovic, M. and Antic, V. (2022) 'WK-FNN design for detection of anomalies in the computer network traffic', *FACTA UNIVERSITATIS, Series: Electronics and Energetics*, 35(2), pp. 269-282. <https://doi.org/10.2298/FUEE220269P/>
- Quinlan, J.R. (1986) 'Intrusion detection trees', In: *Machine Learning 1*, Boston: Kluwer Academic Publisher, pp. 81-106.
- Sasidhar, J. (2020) 'Machine learning algorithms in network security', *Culminating projects in information assurance*, 99, pp. 1-81.
- Sebastiani, F. (2002) 'Machine learning in automated text categorization', *ACM Computing Surveys*, 34(1), pp. 1-47.
- Serkani, E., Gharaee, H. and Mohammadzadeh, N. (nd) 'Anomaly detection using SVM as classifier and DT for optimizing feature vectors', *IseCure*, 11(2), pp. 159-171.
- Siddiqui, M.A. and Pak, W. (2020) 'Optimizing filter-based feature selection method flow for intrusion detection system', *MDPI Electronics*, pp. 1-18.
- Singh, S. and Banerjee, S. (2020) 'Machine learning mechanisms for network anomaly detection system: A review', *International Conference on Communications and Signal Processing*, pp. 0976-0980, <https://doi.org/10.1109/ICCCSP4568.2020.9182197>
- Srivastava, N., Lambda, T. and Agarwal, M. (2020) 'Comparative analysis of different machine learning

techniques”, In: *Futuristic Trends in Network and Computing Technologies*, Singapore: Springer Nature.

Thakkar, A and Lohiya, R. (2020) ‘Attack classification using feature selection techniques: a comparative study’, *Journal of Ambient Intelligence and Humanized Computing* <http://doi.org/10.1007/s12652-020-02167-9>

Vallejo-Huanga, D., Ambuludi, M. and Morillo, P. (2021) ‘Empirical exploration machine learning techniques for detection of anomalies based on NIDS’, *IEEE Latin America Transactions*, 19(5), pp. 772-779.

Vimalkumar, K. and Radhika, N. (2017) ‘A big data framework for intrusion detection in smart grids using Apache Sparm’, *International conference on advances in computing, Piscataway: IEEE*, pp. 198-204.

Wang, S., Cai, C.X., Tseng, Y.W. and Lin, K.S.M. (2020) ‘Feature selection for malicious traffic detection with machine learning’, *2020 IEEE International Computer Symposium*, pp. 414-419. <https://doi.org/10.1109/ICSS1289.2020.00088>

Yousef, A.T., Mourabit, E., Bouirden, A. and Moussadir, N.E. (2015) ‘Intrusion detection techniques in wireless sensor network using data mining algorithms: Comparative evaluation based on attacks detection’, *International Journal of Advanced Computer Science and Applications*, 6(9), pp. 164-172.

Zhao, M. and Chen, J. (2016) ‘Improvement in comparison of weighted k nearest neighbour classifiers for model selection’, *Journal of Software Engineering*, 10, pp. 109-118.

## BIOGRAPHY

**Danijela Protic** received a diploma in electrical engineering from the Faculty of Technical Science, University of Novi Sad and a MSc degree in computer science from Faculty of Electrical Engineering, University of Belgrade. Her main areas of research include information security, machine learning, neural networks and anomaly detection.

She is currently working at the Centre for Applied Mathematics and Electronics, Belgrade.





DUŠAN TATIĆ<sup>1</sup>  
PETAR VRANIĆ<sup>2</sup>  
BOJAN TEŠIĆ<sup>3</sup>  
MIOMIR STANKOVIĆ<sup>4</sup>

## AN AUGMENTED REALITY-BASED OCCUPATIONAL SAFETY SYSTEM - USERS' EVALUATION

<sup>1,2,4</sup>Mathematical Institute of the  
Serbian Academy of Sciences and  
Arts

<sup>3</sup>Mine and Power Plant Ugljevik

<sup>1</sup>dule\_tatic@yahoo.com

<sup>2</sup>petarvvv@gmail.com

<sup>3</sup>bojan\_pupi@hotmail.com

<sup>4</sup>miomir.stankovic@gmail.com

**Abstract:** *The rapid development of information technology has enabled industrial progress and led to the Fourth Industrial Revolution (Industry 4.0). The particular application of information technology is in the field of occupational safety. Augmented reality is an emerging technology that uses virtual information overlaid in real-world environments and it can help avoid risk factors and prevent injuries. In this paper, we present an augmented reality system based on occupational safety concepts to assist workers in safely completing given tasks. In addition, we provide workers evaluations after testing the presented augmented reality system in an industrial environment.*

**Keywords:** augmented reality, users evaluation, industry, occupational safety

### INTRODUCTION

The rapid development of information technology has enabled industrial progress and led to the Fourth Industrial Revolution (Industry 4.0). Consequently, the industry's procedures have become increasingly automated. Moreover, these technologies enhanced remote communication with the machines in the industrial environment to make production more efficient.

Augmented reality (AR) is an emerging technology that enhances the processes in the industry by introducing a new way of interaction. It uses hardware system camera and specific software to recognize objects of interest. Once the object of interest is recognized, it is possible to overlay its environment with specific virtual information. Virtual information should precisely align with an industrial environment, so that it appears to be a part of the real world. In such a way AR technology opens up the possibility for workers to improve their efficiency by interacting with machines in virtual space.

There is a broad range of research on the application of AR technology in the industry field (Palmarini *et al.*, 2018; Bottani and Vignali, 2019). For example, task execution in an industrial environment, i.e. the support of workers in task accomplishment throughout the operational process (Wang *et al.*, 2014). In the same way, maintenance and repair processes of complex industrial systems are associated with AR to improve the way the necessary instructions are displayed (Scurati *et al.*, 2018). Further, AR is applied in training sessions as a tool for increasing workers' knowledge in solving specific tasks in the industry (Webel *et al.*, 2013). Only recently the application of AR technology has been explored for occupational safety in the industry environment (Kim, Nussbaum and Gabbard,

2016; Vignali, *et al.*, 2019). The purpose of AR usage in this field is to advance the quality of work, reduce risk factors, and prevent injuries. In this paper, we present a user evaluation of the AR-based system for occupational safety (AROS-system). This system was created to assist workers execute assigned tasks in a safe manner. The paper shows the results of the survey filled out by workers after they use the system. Interpretation of the results is provided following workers' evaluation in order to validate the developed AR occupational safety system.

### AR SYSTEM

In the previous work, the AROS system was presented (Tatić and Tešić, 2015; Tatić and Tešić, 2017). The AROS system aimed to improve technological processes in the industry environment and help prevent injuries and risks at the workplace. In this section, a brief description of the AROS system is provided as an introduction to the evaluation presented in the next section.

The primary goal of the AROS system was to address risk situations by improving existing occupational safety measures and procedures in the Maintenance and Repair Unit of the Mine and Power Plant Ugljevik. The analysis of injuries conducted for the period 2002-2011, showed the Maintenance Department as the one where the most common injuries were recorded. This department is equipped with several combined lathes and other tools specific to the power plant. The conclusion pointed out inadequate training as a prime cause of injuries on the universal lathe, on which the majority of injuries have happened, when it comes to low-skilled workers. Further, injuries among higher-skilled workers are most often related to the job



monotony and routine performance of tasks due that lead to neglecting prescribed safety measures.

Based on the previous facts technological process was reconsidered to determine task execution order at the power plant. Each task was defined as an ordered set of safety and work instructions defined by experts within the industrial environment. The structure of the AROS system is based on the protocol of issued instructions. It is designed to provide work tasks and related safety measures for instructing the workers to perform the tasks safely. It is implemented as a step-wise system. Firstly, it visualizes safety instruction employing AR technology. After displaying the corresponding multimedia content, the checklist is given as a confirmation step to verify if the required instruction was viewed and performed. Only after a positive confirmation, does the system enables a worker to obtain the following work instruction.

To perform the task safely, the worker uses a mobile device with an embedded AROS system application directly at the workplace. When the worker login to the system, he is instructed to find the given marker (the object of the AR recognition) and scan it with the camera. By recognising this marker, the related safety instruction is provided as multimedia information over the image of a real industrial environment. After the safety instruction is displayed, the worker is obliged to go through a double-check method using the checklist to verify the performed instruction and issue the next work instruction. The cycle is repeated until the last instruction is executed and then the data is sent to the server and stored in the database. This achieves the preservation of data on completed tasks that can be used for further analysis and business improvement.

## **EVALUATION OF THE SYSTEM**

### **Survey**

The characteristics of the AROS system were evaluated by a survey of workers in the workplace environment. The evaluation was provided after the workers had finished the task that concerns the usage of a universal combined lathe at the Maintenance and Repair Unit (MRU) of the Mine and Power Plant Ugljevik with the help of the AROS system.

By the usage of the AROS system workers are navigated to find and recognise the markers at the workplace in order to realise a given task. Each instruction is associated with a single dedicated marker that has a unique visual structure for recognition. Therefore, there were nine different markers for safety and nine distinct markers for instructions. Once the marker was recognised the instructions are provided.

After completion of the task, each worker completed an evaluation of the system by filling out a questionnaire concerning the characteristics of the AROS system. The questionnaire consists of four sections, three of which are quantitative in nature:

1. General evaluation of the system - assesses the system's suitability for industry use.
2. System usage - examines the effectiveness of the system in the way the instructions are provided.
3. System efficiency - measures the impact of the system's usability in the industry concerning knowledge and skills improvement.

Also, there is one qualitative section

4. System improvement - is used for critical review of how well now are current system performance and what will be potential areas of enhancement.

Quantitative sections contained a sequence of questions, and the worker was able to select an answer on a scale of 1 (insufficient, strongly disagree) to 5 (excellent, strongly agree). While for the qualitative section workers were required to give a descriptive answer.

The General evaluation of the system section was organized as a set of questions that measure the overall satisfaction of workers with the system. Therefore, questions are related to how the system aids in the execution of the work process and whether the information provided was sufficient. Also, questions in this section concerned the improvement of safety measures or the usefulness of the system as a tool during the work.

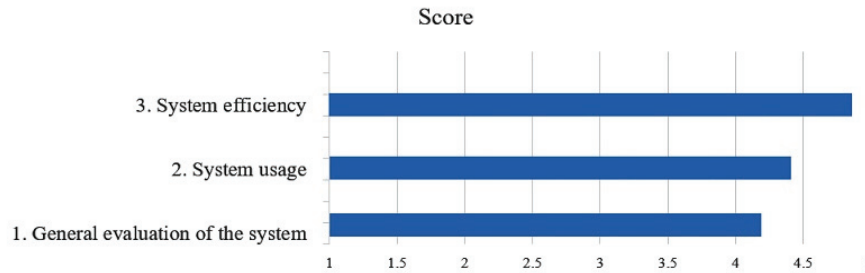
The System usage is a section that evaluates worker experience with handling the AROS system. The given questions concerned easiness of the usage, comfort with it during the work, or satisfaction with the acceleration of execution of the designated task using the system. Also, workers have to answer the questions about the quality, satisfaction, and clearness of AR visualization for safety and work instructions.

System efficiency is a section about the ability of the AROS to effectively support workers in task execution. It reflects on the system's simplicity, usefulness for training and knowledge improvement, or usability for workers of various skill levels. In addition, the remaining questions concern whether or not the system is superior to the conventional operating manual and how much the system may have improved the workers' knowledge.

The System improvement is the section where workers could express their critical opinion about the AROS system. Workers were able to reflect on the difficulties they potentially experienced using the system or highlight the advantages of this system. They could also express opinions on how system performance can be improved.

### **Results and Discussion**

The evaluation questionnaire was completed by 10 workers and the results are given in Figure 1. All quantitative sections are rated as follows:



**Figure 1.** Conducted results of the questionnaire

- General evaluation of the system with a score of 4.18,
- System usage with a score of 4.39,
- System efficiency with a score of 4.86.

Considering all scores, the general quality of the system is perceived as good since the individual scores are greater than 4 out of a possible 5. The workers perceived System efficiency as the best aspect of the AROS system grading it with a score of 4.86; then follows System usage with a score of 4.39, and General evaluation of the system with a score of 4.18. A detailed analysis of the results is presented below.

The results of the section General evaluation of the system are given in Table 1a. As the figure shows, workers recognize the significant capability of the system to improve safety measures (score of 4.50). Also, the general performance of the system is seen as satisfying (score of 4.40). These results are because the system prominently improves occupational safety measures, requiring workers have to pass all safety procedures and verified them. Furthermore, workers perceived the sufficiency of the information displayed using the system at work as good (score of 4.10). There's a similar impression about the AROS system's usefulness as a tool during work. These results show workers have a dominantly positive view of the way system is used for the presentation of instructions during work as well as the amount of information provided. A moderately lower score the system received when it comes to assisting workers performing the task (score of 3.8). We assume that this score is due to the novelty of the system, i.e., workers need time to adapt to the usage.

Table 1b depicts the results of the section on System usage. The clarity of the displayed instructions receives the highest score of 4.70 in this section. These results indicate that provided information by AROS is acceptable to the workers at the workplace during work. Additionally, the perception of the quality of safety and work instructions implemented as a video is rated with a score of 4.50 and 4.60. This suggests that the multimedia video solution, where the video is overlaid with real-world images at the working station, is well accepted by the workers. The aspect of the ease of use of the system during work has a moderately lower score of 4.30. This might be because workers

need additional exercise to adapt to the system. The aspects concerning the comfort while using the system and acceleration of execution of working tasks have the lowest score of 4.00. Those scores must be considered arbitrary due to short amount of time that the workers had to test the system. The inclusion of the additional tool changed the comfort of routine work and increased time spent during the operational process by watching each instruction and its confirmation, which may have distorted the perception of observed system qualities.

The results presented in Table 1c are for the System efficiency section. The comparison of the efficiency of the system with classical manuals received the highest rating of 5.00. The workers considered the system a significant improvement over manuals in their work environment. Moreover, they believe that system can improve their knowledge as they rated the third question with a score of 4.90. Similarly, the response to the fourth question verified that the system is simple and understandable to use, which was rated with a score of 4.80. The answers to the first and fifth questions (both rated with a score of 4.80) indicated that the system as a tool for training was well accepted by workers and can be used by workers of all qualifications.

The System improvement section concerns answers to the questions about workers' opinions of the system. A critical review was carried out through the three questions. The first question highlights the problems that workers had when using the system. According to the worker's answers, the number of markers should be reduced. The second question enables workers to quote the advantage of the system. The answer to this question indicates the system represents significant help in the application of occupational safety measures. Accordingly, workers stand out that the system plays a significant role in connecting theoretical and practical knowledge during the work process with increased safety. Also, based on the surveyed workers believe a system implemented in this way can be used effectively even in a training phase. The third question indicates what workers would add or change to improve the performance of the system. In answers to these questions, workers proposed to display pictures of accidents using the system as one way to highlight greater caution at work.

**Table 1.** Results of the a) General evaluation of the system section, b) System usage questionnaire section, and c) System efficiency questionnaire section

a) General evaluation of the system	
Question	Score
1. To what degree the system helps in the execution of work tasks?	3.80
2. Sufficiency of information displayed using the system during the work.	4.10
3. To what degree the system improves occupational safety measures?	4.50
4. How would you grade overall performance of the system?	4.40
5. Evaluate system usage as a tool during work.	4.10
b) System usage	
Question	Score
1. Rate ease of use of the system during operation.	4.30
2. Rate the way work instructions are displayed.	4.50
3. Rate the way safety instructions are displayed.	4.60
4. Rate the way video instructions are displayed.	4.60
5. Rate comfort while using the system.	4.00
6. To what extent the information in the system is clearly displayed?	4.70
7. To what extent are you satisfied how the system accelerates execution of the working task?	4.00
c) System efficiency	
Question	Score
1. Rate how good the system is in training workers.	4.80
2. Rate the efficiency of the system in comparison with conventional operating manual.	5.00
3. Did you improve your knowledge by using the system?	4.90
4. Rate how simple the system is to use and understand.	4.80
5. Rate the usability of the system by workers of all skill levels.	4.80

## CONCLUSION

The exponential growth of information technologies enabled many advancements in industrial systems. The use of AR technology is a research topic in Industry 4.0. As a result, the application of AR technology can be used as a convenient tool for the execution of work tasks in an industrial environment. Furthermore, AR technology may be implemented in the areas of maintenance and repair to assist workers at work, as well as in education and training where this technology is adopted as a helpful learning tool.

In this paper, we presented an AR system that applies occupational safety and work instructions to help workers complete given tasks safely. The performance of this system is validated through an evaluation questionnaire. This evaluation questionnaire contained four sections with the set of questions that workers filled out after the usage of the system.

Based on the questionnaire results, the system is perceived as an efficient tool compared to classical manuals and is usable by workers of different skill

levels. Moreover, based on the questionnaire results, the system was determined as effective for both the protection of workers and the execution of work tasks. Because the necessary information is obtained in an intuitive way, the system was rated as suitable to use. However, it was found that workers need more time to adapt to new technology. That is why it is necessary to provide the appropriate training on how to use the AROS system.

The questionnaire's limitation was that it only evaluated workers from one sector of the Mine and Power Plant Ugljevik. Future research will evaluate various sectors and industrial environments where more workers will be involved in more detailed analysis.

## REFERENCES

- Bottani, E. and Vignali, G. (2019). 'Augmented reality technology in the manufacturing industry: A review of the last decade', *IISE Transactions*, 51(3), pp. 284-310.
- Kim, S., Nussbaum, M. A. and Gabbard, J. L. (2016). 'Augmented reality "smart glasses" in the workplace:

industry perspectives and challenges for worker safety and health', *IIE transactions on occupational ergonomics and human factors*, 4(4), pp. 253-258.

Palmarini, R., Erkoyuncu, J. A., Roy, R. and Torabmostaedi, H. (2018). 'A systematic review of augmented reality applications in maintenance', *Robotics and Computer-Integrated Manufacturing*, 49, pp. 215-228.

Scurati, G. W., Gattullo, M., Fiorentino, M., Ferrise, F., Bordegoni, M. and Uva, A. E. (2018). 'Converting maintenance actions into standard symbols for Augmented Reality applications in Industry 4.0', *Computers in Industry*, 98, pp. 68-79.

Tatić, D. and Tešić, B. (2015). 'Improvement of occupational safety systems by the application of augmented reality technologies', In *23rd Telecommunications Forum Telfor (TELFOR)*, pp. 962-965.

Tatić, D. and Tešić, B. (2017). 'The application of augmented reality technologies for the improvement of occupational safety in an industrial environment', *Computers in Industry*, 85, pp. 1-10.

Vignali, G., Bottani, E., Guareschi, N., Di Donato, L., Ferraro, A., Pirozzi, M. and Longo, F. (2019). 'Development of a 4.0 industry application for increasing occupational safety: guidelines for a correct approach', In *2019 IEEE International Conference on Engineering, Technology and Innovation (ICE/ITMC)*, pp. 1-6.

Wang, X., Truijens, M., Hou, L., Wang, Y. and Zhou, Y. (2014). 'Integrating Augmented Reality with Building Information Modeling: Onsite construction process controlling for liquefied natural gas industry', *Automation in Construction*, 40, pp. 96-105.

Webel, S., Bockholt, U., Engelke, T., Gavish, N., Olbrich, M. and Preusche, C. (2013). 'An augmented reality training platform for assembly and maintenance skills', *Robotics and autonomous systems*, 61(4), pp. 398-403.

## ACKNOWLEDGEMENTS

This work was supported by the Serbian Ministry of Education, Science, and Technological Development through the Mathematical Institute of the Serbian Academy of Sciences and Arts.

## BIOGRAPHY of the first author

**Dušan Tatić** received the Master of Science degree in Computer Science and the Ph.D. degree in Electrical Engineering and Computer Science at the Faculty of Electronic Engineering, University of Niš. His research interests primarily concern augmented reality technologies and their application in an industrial environment. Also, he realizes research concerning the applications of augmented reality and multimedia technologies in the presentation of the national historical, cultural, technical, and scientific heritage of Serbia. Currently, he is engaged as a research associate at the Mathematical Institute of the Serbian Academy of Sciences and Arts.





BRATIMIR NEŠIĆ<sup>1</sup>  
JELENA MALENOVIĆ  
NIKOLIĆ<sup>2</sup>

<sup>1</sup>Academy of Technical and  
Vocational Studies Niš,  
<sup>2</sup>University of Niš,  
Faculty of Occupational Safety

<sup>1</sup>bratimir@gmail.com  
<sup>2</sup>jelena.malenovic@znrfak.ni.ac.rs

## UNUTILIZED ENERGY POTENTIAL OF MSW DEPOSITED AT LESKOVAC SANITARY LANDFILL IN 2021

**Abstract:** *In addition to material recycling, MSW (municipal solid waste) can be treated by the so-called energy recycling or thermal treatment with energy recovery. The basic conditions that need to be met for this are that municipal solid waste cannot justifiably be treated with priority material recycling and that it should have the energy potential that is acceptable for energy recycling. However, some amounts of municipal solid waste are disposed of instead of being subjected to energy recovery, in which case certain energy losses occur. This paper presents and describes the losses of energy potential due to the disposal of municipal solid waste at the regional sanitary landfill in Leskovac in 2021, and the emphasis is on the calculation of unused energy potential.*

**Key words:** unutilized energy potential, waste, landfill.

### INTRODUCTION

Municipal solid waste comprises household waste and other waste similar to household waste due to its nature and composition, such as non-hazardous waste from industry, commercial, administrative and other institutions, hospitals, craft shops, construction waste (gravel, soil, mixed waste from construction sites), green market waste, garden waste, green waste from parks and cemeteries and waste after street cleaning (Nešić, 2010A).

The option that lies between recycling and landfilling in waste management operations – energy recycling or thermal treatment in order to obtain energy, i.e. energy recovery, is mentioned only sporadically in our country, more as a theoretical possibility, even in academic circles. No serious analyses were conducted in terms of the quality of municipal solid waste, and especially not in terms of its energy potential.

Based on the morphology of the waste, it can be concluded that biodegradable waste dominates in Serbia and that its quality in terms of energy is generally poor due to the significant moisture content (up to 37%). This means that, without pre-treatment, the full potential of thermal treatment of municipal solid waste cannot be exploited.

In addition, controlled combustion in plants is also met with great resistance from the public due to fears of increased pollution. Although the arguments presented as proof of pollution are generally not scientifically and practically good and valid, they still figure among environmental organizations and individuals as good and valid.

Another aggravating circumstance for wider application is the direct or indirect opposition to traditional or material recycling. Thermal treatment or controlled combustion in order to obtain energy should not and must not compete with material recycling, because only the waste that cannot be recycled and that has satisfactory thermal power, i.e. energy potential, should be thermally treated. Nevertheless, considering the already reduced energy quality of municipal solid waste, by subtracting fractions for recycling, such as plastic, paper or textiles, the already low thermal power, i.e. energy potential, will also be reduced.

This paper presents the energy losses that occurred due to the disposal of municipal solid waste at the regional sanitary landfill in Leskovac in 2021. The emphasis is on the calculation of the unused energy potential only of the deposited municipal solid waste, which means that sludge and other liquid municipal wastes will not be considered.

### MATERIAL AND METHOD

In order to obtain data on the amount of municipal solid waste, it is necessary to implement the prescribed methodology for collecting data on the composition and amount of municipal solid waste in the territory of the local self-government unit (The Official Gazette of Republic of Serbia 61/2010, Vujić, 2009, The Official Gazette of Republic of Serbia 56/2010, 93/2019, 39/2021). The obtained data are analysed and evaluated. However, it should be noted that these results cannot be taken as a definitive indicator of the generated amounts of municipal solid waste because there are significant and constant seasonal variations. This only further confirms the fact that measurements of generated amounts of municipal solid waste are very

important for the entire waste management system and should be carried out constantly throughout the year. The morphological composition of the waste will be the starting point for further analysis, which is the separation of components that have satisfactory thermal power (Stanković, 2020).

The characteristics of municipal solid waste, which can potentially become an energy resource, depend on several factors, including the type of development, saturation of the area with non-residential buildings (including business premises), technical equipment of buildings, and their heating. The following elements are equally important for the composition of municipal solid waste: the wealth of the inhabitants, the season, the existence and function of composters for green waste in the yard and the selective collection of recyclable waste by the population (Midor, 2017).

The reason for the decrease or increase in the amount of municipal waste per inhabitant warrants a separate analysis. The reasons may include an increase or decrease in the standard of living, but also an increase in the population's awareness of the importance of reducing waste generation. Based on annual reports on waste management for 2021 (GIO2, 2022; KOM1, 2022), the total amount of municipal solid waste deposited at the regional sanitary landfill in Leskovac is  $M = 72,680$  t.

When considering the possibility of energy utilization of municipal solid waste in plants and designing them, as with any fuel, the following characteristics must be known: chemical composition of municipal solid waste as fuel, morphological (physical) composition of municipal solid waste as fuel and thermal characteristics of municipal solid waste as fuel. Analyses of chemical composition most often refer to the determination of key elements: carbon, hydrogen, oxygen, nitrogen and sulfur.

When the chemical composition of municipal solid waste is analyzed in terms of its energy potential, it can be said that, like other fuels, it consists of combustible and non-combustible parts. The combustible part consists of: carbon (C), hydrogen (H) and sulfur (S), while the non-combustible part consists of impurities such as oxygen (O), nitrogen (N) and ballast (Akinshilo, 2018). Ballast consists of mineral admixtures (A) and water (W). Mineral substances (impurities) create ash in the combustion process. In practice, the term ash is often used for the state before combustion. This is incorrect terminology because the composition of mineral matter changes before and after combustion. Mineral impurities and moisture are not elements, but they are conditionally included in the elemental analysis and form the so-called external ballast.

The most important component is carbon, the combustion of which produces the largest portion of heat (34 GJ/t), so the presence of fractions with the most carbon (paper, cardboard, plastic, wood, etc.) is

the most important for the process of energy utilization of municipal solid waste. It is fairly obvious that mineral impurities and moisture are undesirable substances. Municipal solid waste has an average heat value ranging from 7 to 15 GJ/t. The thermal power of municipal solid waste in underdeveloped countries is very low and amounts to about 3 GJ/t, while in developed countries it is over 12 GJ/t. Table 1 shows the elemental composition and thermal power of municipal solid waste (Radovanović, 1994; Nešić, 2010B).

**Table 1.** Elementary Composition of Municipal Solid Waste (Radovanović, 1994; Nešić, 2010B)

Element	Content (%)
Water	15 – 40
Ash	20 – 35
Carbon	18 – 40
Hydrogen	1 – 5
Nitrogen	0.2 – 1.5
Oxygen	15 – 22
Sulfur	0.1 – 0.5

For the thermal treatment of municipal solid waste, thermal power is the most important characteristic, which is defined as the ratio of the released amount of heat during complete combustion of the fuel and the amount of fuel from which the heat was released (Radovanović, 1994):

$$H = \frac{Q}{m}, \quad (1)$$

where:

H (GJ/t) – thermal power;

Q (GJ) – released amount of heat;

m (t) – mass of municipal solid waste as fuel.

Moisture reduces the thermal power because part of the heat produced by combustion is used for its evaporation. Accordingly, there is a lower heat capacity ( $H_d$ ) and an upper heat capacity ( $H_g$ ). The lower heat output is the energy released after complete combustion of the fuel (waste) with the water leaving the process in a vapor state (water vapour). Complete combustion implies complete oxidation of carbon to  $CO_2$ , hydrogen to  $H_2O$  and sulfur to  $SO_2$ , with no oxidation of nitrogen. The difference between  $H_g$  and  $H_d$  represents the energy required to convert the process water from liquid to vapor state (Radovanović, 1994). In most waste incineration systems, water leaves the plant in vapor form.

Municipal solid waste, as a potential fuel, is very heterogeneous and significantly different from conventional fossil fuels. Calculating the heat value of municipal waste is a complex process for which it is very important to determine representative samples for

analysis, with possible variations that can affect the final result. Due to large differences in waste composition among waste types and variations over time, it is not easy to obtain a representative sample in order to obtain a reliable estimate of the average thermal power. The thermal power of municipal solid waste would be most accurately determined by testing in an existing thermal treatment plant, by measuring the thermal power for each waste fraction using a calorimeter. The procedure involves burning a known mass of waste in the presence of oxygen. The amount of energy released during combustion is determined based on the temperature increase in the calorimeter (Radovanović, 1994).

Very often, the upper and lower heating power of combustible fractions are given in the literature (Vujić, 2012; Lokahita, 2017), where a big difference between the upper and lower heating power of some fractions can be observed. Of course, the lower thermal power is relevant for the realistic calculation.

All fractions in municipal solid waste do not have sufficient thermal power to be considered as a possible energy source. Fractions that are suitable for controlled combustion in order to obtain energy are given in table 2.

**Table 2.** Thermal Powers of Waste Fractions (Vujić, 2012; Lokahita, 2017)

Fractions of waste that have satisfactory thermal power	Lower thermal power (GJ/t)
Paper & cardboard	11.6 – 18.6
Plastic	28 – 37.2
Textile	15 – 18.6
Rubber	21 – 28
Composite materials	25.22
Biodegradable waste	3.5 – 18.6
Fine elements	2.6

It should be emphasized that the obtained values of thermal powers refer to municipal solid waste from bins and containers. By introducing primary selection to obtain recyclable materials, the thermal power would have lower values considering the separated components rich in energy potential.

The assessment of the energy potential of municipal solid waste deposited at the regional sanitary landfill in Leskovac in 2021 involves the procedure of separating fractions that have satisfactory thermal power and neglecting fractions without energy potential.

Given that the thermal power of the combustible fractions is known, according to the quantitative composition of those fractions in the waste, the value of the thermal power of the fraction, i.e. the entire municipal solid waste, can be determined by adding the heat values of its fractions.

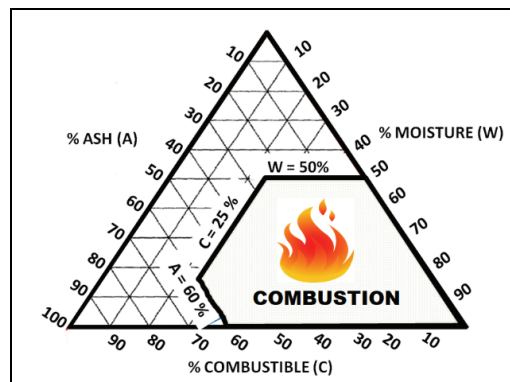
The following fractions take part in the calculation: paper and cardboard, plastic, textile, rubber, composite materials (Tetra Pak packaging), biodegradable waste and fine elements. That is why the mass share of all combustible fractions in total is less than 100%, because the rest of the mass share is made up of non-combustible fractions. The morphological composition of municipal solid waste deposited at the regional sanitary landfill in Leskovac in 2021 is shown in Table 3.

**Table 3.** Morphological composition of municipal solid waste deposited at the regional sanitary landfill in Leskovac in 2021 (KOMI, 2022)

Fraction	Mass share (%)
Paper & cardboard	0.33
Glass	0.02
Biodegradable waste	86.29
PET packaging	0.15
Other plastic packaging waste	0.06
Other plastic	0.02
Ferrous metal packaging	0.06
Metal – aluminium cans	0.01
Composite materials	0.00
Rubber	0.86
Textile	0.00
Fine elements	9.87
Other	2.33
<b>TOTAL</b>	<b>100.00</b>

There is also an indirect way to calculate the thermal power by applying appropriate formulas, for which it is necessary to know the content of ash, moisture and combustible materials. For that, it is necessary to determine the following content in the waste, under specific conditions (Cvetanović, 2018):

- A – ash content (typically 10-25% after burning at e.g. 550°C);
- W – moisture content in the waste (typically 15-35% when dried at 105°C);
- B – share of flammable solid fraction (mass share of fuel ingredients, i.e. carbon + volatiles).



**Figure 1.** Tanner's Diagram (Cvetanović, 2018)

If the data (moisture  $W < 50\%$ , ash  $A < 60\%$ , fuel material  $V > 25\%$ ) are in the red shaded part of Tanner's diagram shown in Figure 1 (Cvetanović, 2018), this indicates that the combustion process does not need auxiliary fuel, i.e. the waste is considered suitable for conversion into energy through thermal treatment. If the quantities A, B and W are known, it can be determined whether the waste can burn without auxiliary fuel.

Although the values of thermal powers vary greatly among different authors, the average lower thermal powers that appear in the literature for combustible fractions are considered here so as not to create a false image of the high energy potential of municipal solid waste, especially as the actual state would be diminished for recyclable fractions. The formula for calculating the energy potential of an individual combustible fraction of municipal solid waste is

$$E_{PGFi} = m_{GF_i} \cdot H_{dGF_i}$$

where:

$E_{PGFi}$  (GJ/t) – energy potential of an individual combustible fraction of municipal solid waste;  
 $m_{PGFi}$  (-) – mass share of an individual combustible fraction in the total mass of municipal solid waste;  
 $H_{dPGFi}$  (GJ/t) – thermal power of an individual combustible fraction of municipal solid waste.

The total mass fraction of combustible fractions of municipal solid waste deposited at the regional sanitary landfill in Leskovac in 2021 is calculated according to the formula:

$$m_{GFU} = \sum_{k=1}^7 m_{GF_i}$$

The total energy potential (GJ/t) of the combustible fractions of municipal solid waste deposited at the regional sanitary landfill in Leskovac in 2021 is calculated according to the formula

$$H_{dGFU} = \sum_{k=1}^7 H_{dGF_i}$$

The total energy losses due to the disposal of the combustible fractions of municipal solid waste at the regional sanitary landfill in Leskovac in 2021 are calculated according to the formulas

$$E_{GU} \text{ (GJ/year)} = m_{GFU} \cdot H_{dGFU} \cdot M,$$

$$E_{GU} \text{ (MWh/year)} = E_{GU} \text{ (GJ/year)} \cdot 1000/3600.$$

Table 4 shows the energy potential of municipal solid waste deposited at the regional sanitary landfill in Leskovac in 2021. After adding the values of the energy potentials of all individual combustible waste fractions, the total energy potential of municipal solid waste deposited at the regional sanitary landfill in Leskovac in 2021 is 10.19 GJ/t.

Given that the limit of the energy potential for thermal treatment using municipal solid waste combustion technology to obtain energy is 8 GJ/t, it is obvious that combustible fractions of the municipal solid waste deposited at the regional sanitary landfill in Leskovac in 2021 meet this requirement in terms of energy potential.

**Table 4.** Energy potential of municipal solid waste deposited at the regional sanitary landfill in Leskovac in 2021

Combustible fraction of municipal solid waste	Mass share of combust. fraction (%)	Mass share of combust. fraction $m_{GF_i}$ (-)	Lower thermal power of combust. fraction $H_{di}$ (GJ/t)	Energy potential of combust. fraction $H_{dGF_i}$ (GJ/t)
Paper & cardboard	0.33	0.0033	16.3	0.054
Plastic	0.23	0.0023	32.6	0.075
Textile	0.00	0.00	16.8	0.00
Rubber	0.86	0.0086	30.2	0.26
Composite materials	0.00	0.00	25.22	0.00
Biodegradable waste	86.29	0.8629	11.05	9.54
Fine elements	9.87	0.0987	2.6	0.26
$m_{GFU}$	97.58	0.9758	$H_{dGFU}$	10.19
Total energy losses $E_{GU}$ (GJ/year)				723
Total energy losses $E_{GU}$ (MWh/year)				200.83

## RESULT ANALYSIS

Although it is completely clear that this is only a calculation method, the values of the thermal power of municipal solid waste represent the starting point for further analyses. If there are enough other data on municipal waste, for example, the chemical composition of waste fractions, the heat power values can be calculated and compared using other calculation methods.

With regard to approximately correct values, possible systematic errors arise due to the fact that the starting point is the morphological composition of the waste by season, and the data for the calculation were obtained by calculating the arithmetic mean. Since the amounts of waste per year were not the same, the use of the arithmetic mean already produces the first error in the calculation. The second error comes from the difference in the values of heat powers of individual fractions of municipal solid waste, which can be found in the literature. This paper considered the average values of the lower heating power of the fractions, which can be found in the literature.

Also, these are the literature values that refer to individual fractions with specific humidity and quality, which in practice is often not the case, because the thermal powers are reduced due to excessive humidity, dirtiness, etc. It has been established that the thermal

power of 8 GJ/t is the minimum value with which thermal treatment of waste for energy utilization can be planned and sustainable.

In addition to energy quality, in order to consider the option of thermal treatment of waste for energy purposes, the condition of quantity must also be met, that is, there must always be sufficient amounts of waste for energy recovery. Considering the small amounts of municipal solid waste generated and collected in an organized manner in all local self-governments in Serbia, except for large cities (Belgrade, Niš, Novi Sad, Kragujevac, and Priština), it is necessary to collect waste from several local self-governments, which can pose a logistical, organizational and financial problem.

The result of the calculation of total energy losses of 723 GJ/year can be converted into 17,265 t of equivalent oil or 34,538 t of hard coal or 96,463 t of lignite or 200.83 MWh of electricity (Službeni glasnik Republike Srbije 156/2020).

Based on the current price of 1 MWh of electricity, which, as of 1 September 1 2022, is €629.28-€681.10/MWh (SEPEX, 2022), total energy losses due to disposal of municipal solid waste at the regional sanitary landfill in Leskovac during 2021 turn into total but exclusively gross financial losses, which are in the range of €126,378.30-€136,785.31/year.

## CONCLUSION

In the management of municipal solid waste, the tendency is to use all treatment options except, of course, disposal to the landfills. Thermal treatment of municipal solid waste for energy is an option standing between recycling and disposal.

It seems that almost all countries see that option as a 'necessary evil', that is, they choose it when all other options have been exhausted. Even the data on the amount of waste that is treated in this way supports this claim, and it seems that there will not be any significant changes in the coming years.

When the question is asked why this option is so neglected and avoided at all costs, the first answer is because of the public opinion that plants for the thermal treatment of municipal solids pollute the environment. It even seems that the public cannot see the location and the state of landfills and how they pollute the environment. Concerning this argument, it should be emphasized that there are indeed some problems, mainly with the solid content that remains after burning, but not to the extent that is presented. A much bigger problem is the cost of building and maintaining plants for the thermal treatment of waste in order to obtain energy. That is why options for thermal treatment of waste are being sought in some production activities, e.g. cement plants.

When the literature related to this issue in our country is analyzed, no concrete data can be found on the quality of our municipal solid waste. Proximity to municipalities is important because it allows combination of waste quantities with minimal logistical costs. The general conclusion is that energy utilization, i.e. 'energy' recycling is financially profitable and sustainable in many ways compared to 'material' recycling of municipal solid waste.

## REFERENCES

- Akinshilo, A.T., Olofinkua, J.O., Olamide, O., (2018). *Energy potential from municipal solid waste (MSW) for a developing metropolis*, International Journal of Engineering, Tome XVI.
- Cvetanović, B. (2018). *Energetski potencijal otpada (autorizovana predavanja)*, Akademija tehničko-vaspitačkih strukovnih studija, Niš.
- GIO2 – *Godišnji izveštaj o upravljanju komunalnim otpadom za 2021. godinu privrednog društva PWW Deponija Dva DOO Leskovac*, Agencija za zaštitu životne sredine Republike Srbije, Beograd, 2022.
- KOM1 – *Godišnji izveštaj o upravljanju komunalnim otpadom za 2021. godinu privrednog društva PWW Leskovac DOO Leskovac*, Agencija za zaštitu životne sredine Republike Srbije, Beograd, 2022.
- Lokahita, B., Aziz, M., Yoshikawa, K., Takahashi, F. (2017). *Energy and Resource Recovery from Tetra Pak Waste using Hydrothermal Treatment*, The Open Science Framework.
- Midor, K. Jäderko, K. (2017). *Analysis of the energy potential of municipal solid waste for the thermal treatment technology development in Poland*, E3S Web of Conferences 22.
- Nešić, B. (2010A). *Generatori otpada i zagađivači južne i jugoistočne Srbije*, Protecta, Niš, Srbija.
- Nešić, B. (2010B). *Upravljanje komunalnim otpadom i potencijali za reciklažu južne i jugoistočne Srbije*, Protecta, Niš, Srbija.
- Radovanović, M. (1994). *Goriva*, Mašinski fakultet, Beograd.
- Službeni glasnik Republike Srbije 156/2020, *Odluka o utvrđivanju energetske bilansa Republike Srbije za 2021. godinu*.
- Službeni glasnik Republike Srbije 56/2010, 93/2019, 39/2021, *Pravilnik o kategorijama, ispitivanju i klasifikaciji otpada*.
- Službeni glasnik Republike Srbije 61/2010, *Pravilnik o metodologiji za prikupljanje podataka o sastavu i količinama komunalnog otpada na teritoriji jedinice lokalne samouprave*.
- Stanković, S. (2020). *Procena energetskeg potencijala čvrstog komunalnog otpada u urbanim područjima Republike Srbije*, završni master rad, Akademija tehničko-vaspitačkih strukovnih studija, Niš.
- SEPEX a.d. Beograd, licencirani operator za organizovano tržište električne energije (2022), *Tržište električne energije*, available: <http://seepex-spot.rs/sr/>, [Accessed 01 Sep 2022].



Vujić, G. (2009). *Utvrdjivanje sastava otpada i procene količine u cilju definisanja strategije upravljanja sekundarnim sirovinama u sklopu održivog razvoja Republike Srbije*, Fakultet tehničkih nauka, Novi Sad.

Vujić, G. (2012). *Upravljanje otpadom u zemljama u razvoju*, Fakultet tehničkih nauka, Novi Sad.

## **BIOGRAPHY of the first author**

**Bratimir Nešić** was born in Priština, Serbia, in 1969. He earned his B.Sc. degree in environmental engineering and his M.Sc. degree in environmental engineering from the University of Niš, Faculty of Occupational Safety, where he is currently a Ph.D. student.



He is a member of the Serbian Chamber of Engineers, Serbian Association of Safety Engineers, Serbian Solid Waste Association (SeSWA), and International Solid Waste Association (ISWA). Since January 2008, he has worked in Porr Group, Vienna, Austria, PWW Ltd., Branch Office Leskovac, Serbia, as a recycling manager. His main areas of research include waste management, waste to energy, energy from waste, recycling, composting, etc. He also works as a lecturer at the Academy for Technical and Educational Vocational Studies Niš in Niš, Serbia.

MARIJA SAVKOVIĆ<sup>1</sup>  
NIKOLA MIJAILOVIĆ<sup>2</sup>  
CARLO CAIAZZO<sup>3</sup>  
MARKO ĐAPAN<sup>4</sup>  
ARSO VUKIĆEVIĆ<sup>5</sup>

<sup>1,2,3,4,5</sup> University of Kragujevac,  
Faculty of Engineering

<sup>1</sup> marija.savkovic@kg.ac.rs

<sup>2</sup> nmijailovic3@gmail.com

<sup>3</sup> carlocaiazzo@fink.rs

<sup>4</sup> djapan@kg.ac.rs

<sup>5</sup> arso\_kg@yahoo.com

## ADVANCED PHYSICAL ERGONOMICS AND NEUROERGONOMICS RESEARCH ON AN ASSEMBLY WORKSTATION

**Abstract:** *Workers who perform repetitive and tiring activities assembling parts and components into the final product at a traditional assembly workstation often suffer from musculoskeletal disorders (MSDs) and other occupational diseases associated with greater effort of tendons, muscles and nerves on the hands and wrists, and neck and lower back pain. These activities also reduce attention span and concentration, which causes mental fatigue and consequently, errors (which negatively affect the quality of the final product), and in some cases even injuries at work.*

*Manual, monotonous and repetitive assembly tasks can be partially automated by the application of new technologies of Industry 4.0 which provides benefits in terms of minimizing the number of movements, inadequate body positions, bending, twisting, human errors, etc. The main focus of future development of the industry workstations is the human-centric approach and the introduction of a collaborative robot, which is in line with the goals of Industry 5.0.*

*The aim of this paper is to present the results of advanced electro psychophysiology research (electroencephalography - EEG and electromyography - EMG) and the analysis of data collected in real-time by applying innovative technologies (EMG sensors and EEG caps) on a traditional workstation in order to establish the ergonomic risks to which assembly workers are exposed. In this way, it is possible to determine when muscle fatigue and/or reduced attention span and concentration of workers will be likely and which ergonomic risks, that can lead to occupational diseases and injuries at work, may occur. The analysis of the results of the experimental study shows that the assembly workers are exposed to physical and mental overload during the performance of assembly activities.*

**Key words:** assembly workstation, EEG, EMG, golden zone, improvement of workplace safety, safety 4.0

## INTRODUCTION

Workers who perform monotonous, repetitive, and tiring assembly activities at a workstation are constantly exposed to the ergonomic risk of musculoskeletal disorders (MSDs), and in some cases, due to a decrease in attention span and concentration, injuries may occur at work. One of the main goals of contemporary production organizations that operate in accordance with the lean principles and principles of world-class production is the improvement workers' safety and health.

Although production processes in modern industrial systems are largely automated and digitized, there are still workplaces where repetitive work activities that cannot be fully automated are performed. These tasks are monotonous and workers mostly perform them manually. This is mainly due to the high complexity of the assembly activities and the limited flexibility of

traditional assembly workstations. Therefore, there is a need to promote traditional assembly stations in order to improve the health and safety of workers who perform repetitive, tedious, and monotonous assembly activities over a long period of time in an ergonomic position.

The repetitiveness of manual tasks is an important risk factor for the occurrence of MSDs (e.g., carpal tunnel syndrome, wrist tendonitis, etc.) (Ellegast, 2016).

Considering the fact that the appearance of MSDs negatively affects the effectiveness and productivity of workers, it is very important to monitor the muscle activity of the operator when performing repetitive assembly activities at a workstation. In this way, it is possible to establish the load and strain of the muscles of the neck and hands, examine the frequency of pain in these parts of the body, and determine when the first symptoms of MSDs appear.

Assembly workers are exposed to a significant physical workload. Due to reduced worker's attention span and concentration, mental overload and fatigue can occur, which in turn cause errors and irregularities in the assembly of parts and components (which has a negative impact on the quality of the final product). Therefore, it is necessary to monitor the brain activity, mental effort and attentiveness of the operator.

The aim of this research paper is to conduct advanced physical ergonomics and neuroergonomics research on an assembly workstation. The motivation for writing the paper can be found in the fact that it is necessary to measure the muscular and brain activity of operators when performing monotonous and repetitive activities at an assembly workstation in order to identify ergonomic risks that may occur during the execution of assembly activities and tasks.

## **THE SPECIFICS OF ASSEMBLY ACTIVITIES ON TRADITIONAL WORKSTATIONS**

In the fourth industrial revolution, safety and ergonomics at work have a crucial role in organizations. Application of advanced technologies of the Industry 4.0 (I4.0) era fundamentally changes the way of performing assembly activities on traditional assembly workstations through intelligent connectivity and advanced automation. Industry 5.0 brings workers back into the production processes and pays special attention to the human-centric approach.

It is of particular importance that assembly workstations and tools necessary for the implementation of work activities be adapted to the needs of workers in order to improve their safety and health – to reduce work-related injuries and illnesses, create a safer and more pleasant work environment, and improve the physical and mental well-being of workers. If the workstations are not ergonomically designed, in addition to the appearance of musculoskeletal disorders due to mental fatigue, the probability of injuries at work also increases, which further results in a decrease in productivity and worker satisfaction (Gerr et al., 2014).

The application of ergonomic principles to assembly workstations contributes to occupational injury reduction and improves the health of workers (Gerr et al., 2013). Ergonomic design of workplaces is one of the most important prerequisites for improving production processes and creating a more efficient, safer, and more comfortable workplace (Cimino et al., 2009).

Furthermore, performing monotonous, repetitive movements at high speed in awkward body positions increases the strain on the tendons, muscles, and nerves of the hands, the joints of the forearm muscles, and neck muscles, which further increases the risk of MSDs. Numerous studies have shown that MSDs in the wrists and hands are associated with repetitive manual

work (Barr, Barbe, & Clark, 2004; Hansson et al., 2000). According to Mehta (2016), psychological factors at work can have a significant impact on the development of MSDs in workers.

MSDs have negative consequences in working environments given that they cause absenteeism, disability, increased replacement costs (Maakip et al., 2017), and reduced efficiency and productivity (Matos and Arezes 2015). Jones and Kumar (2004) pointed out the fact that musculoskeletal disorders represent 32% of the total costs in the organization and cause 40% of the total loss of time in the organization compared to other occupational and work-related diseases.

Manual assembly activities are an example of repetitive tasks involving the manual handling of low loads at high frequency. Therefore, during assembly activities, workers experience excessive mental and physical effort, fatigue, and discomfort. Also, fatigue and mental strain negatively affect productivity (Finnsgård et al., 2008). Due to the inability to maintain attention for a longer period of time, injuries may occur at work.

In particular, workers who perform assembly activities at a workstation are constantly exposed to cognitive stress. This is caused primarily by the large amount of information that workers receive when performing assembly activities consisting of a large number of components and parts that need to be handled. Hanson and Brodin (2011) pointed out that if there are different variations of components and parts (which are combined into the final product), the complexity of the work increases to a great extent, and this has a significant negative impact on the operator's mental state (Lindblom, Thorvald, 2014). During the manual assembly of components and parts, workers sometimes repeat the same operation several times during the work shift, which negatively affects their concentration and attention (Fisher, 1993). Cognitive load negatively affects workers' attention and reasoning ability (Rabby et al., 2019). In some situations, workers fail to stay alert due to a decrease in attention span (Spath and Braun, 2021).

## **METHODOLOGY**

A detailed review of scientific research papers showed that most of the works that focus on operators who perform manual repetitive tasks of assembling parts and components were mainly based on determining the correct position of the body in order to eliminate the incorrect positions and prevent the occurrence of MSDs (Leider et al., 2015). Less attention is paid to cognitive and perceptual aspects (Fish et al., 1997). According to Wiegmann and Shappell (2001), timely detection of attention deficits could contribute to the prevention of dangerous situations and injuries at work.

Jung and Makeig (1994) showed that the vigilance of workers during the performance of tasks that require an increased concentration of workers can be investigated using brain waves. Parasuraman (2003) pointed out the importance of understanding brain processes in

workers. Electroencephalography (EEG) is one of the most common methods for assessing the cognitive state of the operator (Hohnsbein et al., 1998). Bakshi (2018) detected the cognitive workload of 28 subjects through EEG. Moreover, several authors conducted neuroergonomics tests of brain activity during the manual assembly of a hose. Other studies identified the relationship between cognitive load and changes in the EEG signal (Antonenko et al., 2010; Brouwer et al., 2015; Mijović et al., 2015; Charles and Nixon, 2019).

EEG signals are directly correlated with mental demands experienced during the task (Brookings et al., 1996). The captured EEG signals are analyzed to identify their features by fusing them to define the overall brain activity. They enable direct measurement of brain activity in real-time (Gramann et al., 2011). Moreover, they can estimate the quantitative assessment of alertness levels, which requires expensive computational signal processing (Correa et al., 2014; Zhang et al., 2017). The main advantage of EEG is the possibility of objective measurement (as opposed to subjective methods of self-assessment) of workers' attention in real-time (Mijović et al., 2016).

In industrial scenarios, EEG is widely used to assess the cognitive state and mental workload of workers (Infantolino and Miller, 2014). Foong et al. (2019) used EEG to identify the drowsiness of 29 subjects. Numerous studies evaluated the measurement of cognitive load via the EEG signal (Fath-Berglund, Stahre, 2013; Scalera et al., 2020).

On the other hand, EMG is the most popular and commonly used method for detecting the occurrence and development of muscle fatigue (De Luca, 1997; Freitas et al., 2019). EMG signals represent neuromuscular activities of the human body. They are used to monitor workers' muscle condition and find the maximum lifting load, lifting height, and the number of repetitions that the workers are able to handle before experiencing fatigue, all for the purpose of avoiding overexertion (Gevins et al., 1995).

EMG ergonomics applications are the most widely and successfully used in industry for real-time fatigue monitoring, musculoskeletal risk assessment, and assisted handling devices. EMG is the most commonly used tool in many research papers (He, Zhu, 2017). In contrast to the subjective methods of measuring muscle activity, EMG is characterized by objectivity and reliability. The study of EMG signals can help assess functions at the muscle level and at the level of the nervous system, which controls the muscles.

Bosch et al. (2007) showed EMG manifestations of muscle fatigue of the trapezius muscles during normal (8-hour) and extended (9.5-hour) working days involving light manual work. Bennie et al. (2002) also simulated 8h-hour working days using EMG measurements.

Another study (Björklund et al., 2000) focused on the effect of a repetitive low intensity task to fatigue on shoulder position sense. Molinari et al. (2006) assessed

the changed spectrum of the EMG signals when fatigue occurred during dynamic muscle contraction. Dingwell et al. (2008) pointed out the relation between localized muscle fatigue and changes in muscle movement.

## CASE STUDY

In the experiment, muscle and brain activity was monitored in real-time during the performance of repetitive and monotonous assembly activities. The main goal of monitoring muscle activity in the neck is to determine the load and strain of the neck muscles in order to examine the frequency of neck pain and the onset of the first symptoms of MSDs. Muscle activity was monitored by placing EMG sensors on the trapezius muscles on the subject's neck on the left and right sides (Savković et al., 2022). Brain activity was monitored in order to examine the subject's mental fatigue and, on the basis of the obtained data, determine when attention and concentration decrease (Savković et al., 2022). An EEG cap with electrodes was placed on the subject's head in order to monitor brain activity.

Three master's degree students of the Faculty of Engineering, all of them male, aged between 19 and 21 and between 165 and 190 cm tall, participated in the research. All subjects were right-handed and participated in the study voluntarily. The laboratory where experimental research was carried out is air-conditioned and the microclimatic conditions were under control.

The experiment consisted of two sessions between which the subjects had a 15-minute break. Before the experiment started, the respondents were given detailed instructions on how they should perform the assembly activities. Before the beginning of the first session of the experiment, the subjects listened to a relaxing track for 5 minutes. After receiving the information and listening to the music, the respondents started the work operation by taking the wires and the metal structure after the sound signal. After that, the subjects were supposed to place the wires inside the metal structure according to the instructed pattern, following the instructions they received via a screen, which was at their eye level and at a distance of about half a meter.

After placing the wire at the instructed position on the metal structure, the subjects were supposed to press a button on the screen as a sign that they had completed the operation. This step was repeated several times during the experiment. After the completion of the entire operation, the respondents moved on to the next work operation. They were told that if they made a mistake while assembling the wires, they should disregard the product and continue assembling another product so that they could keep performing the activity.

At the end of operation simulations, the complete product was dismantled and the components were returned to the containers in which they were located.

At the end of the experiment, an oral interview was conducted with the respondents. They answered questions related to the complexity of the task they

were performing and the physical and mental fatigue they felt during the experiment, and they were given the opportunity to make their own suggestions.

An innovative EEG system was used to design and conduct the neuroergonomics experiment. The SMARTING wireless EEG system (mBrainTrain, Serbia) was used for EEG signal acquisition. This device has the ability to record EEG signals with a sampling frequency of 500 Hz and a 24-bit data resolution. The SMARTING EEG amplifier (85x51x12mm, 60g) was connected to a 24-channel EEG cap in the occipital region of the head using an elastic band. The connection between the amplifier and the computer was made using a Bluetooth connection.

For EMG measurements, the muscleBAN (PLUX Wireless Biosignals, Portugal) was used. This wearable wireless (Bluetooth or Bluetooth Low Energy data transmission) device combines a single-channel EMG sensor, triaxial accelerometer and magnetometer and in that way enables real-time acquisition with up to 16-bit resolution at up to a 1000 Hz sampling rate.

### RESULTS AND DISCUSSION

The experiment involved using an EEG system with 24 channels, which were recorded during the entire experiment on the subjects. Only three channels were suitable for further analysis (Figure 1). The signals value is represented as an analog-to-digital conversion value represented in 16 bits. This value hasn't got a physical unit but represents scaled voltage of EEG voltage.

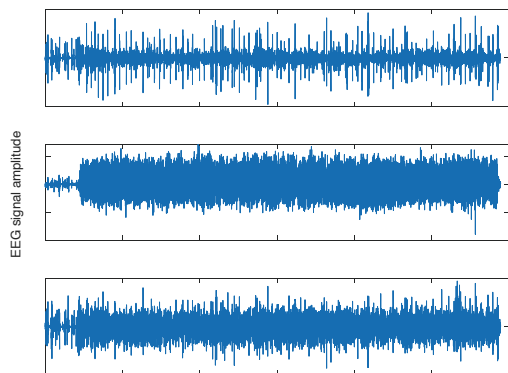


Figure 1. EEG signal amplitude over time

The first step in signal processing was filtering, in order to obtain the corresponding frequency bands. These bands were delta up to 4 Hz, theta from 4 to 8 Hz, alpha from 8 to 13 Hz, beta from 13 to 30 Hz, and gamma from 30 to 100 Hz. The banded signals were now more suitable for further processing (Figure 2).

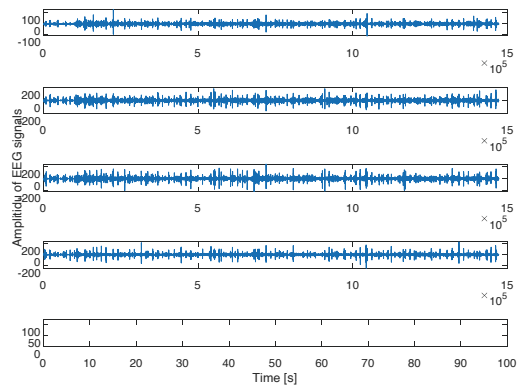


Figure 2. EEG signals for different bands

The following step in EEG signal processing was to calculate the spectra in the frequency domain using a Fourier transform (Figure 3).

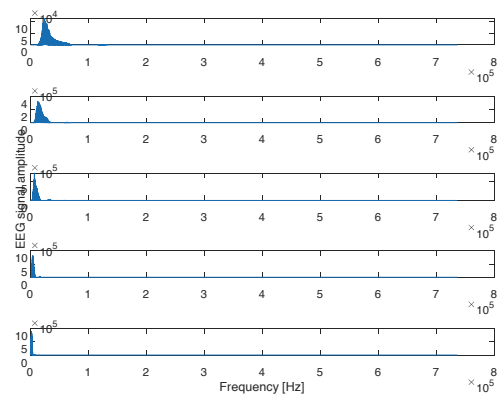


Figure 3. Spectra of one EEG channel for different bands

The EMG signals recorded simultaneously with EEG and the amplitude variation for both sessions of the experiment are shown in Figure 4.

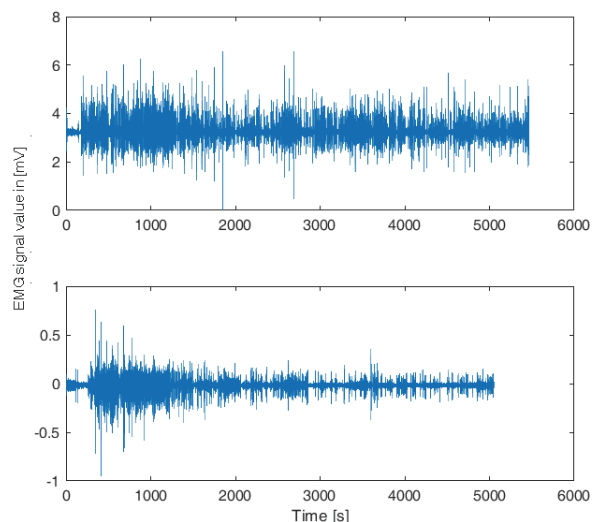


Figure 4. EMG signals in [mV] for both sessions of the experiment during time



Based on the low number of the subjects' experimental results, it can be concluded that EMG data is suitable for classification between both sessions of the experiment. This is because it is easy to notice the difference in signal patterns between the sessions. As a measure of similarity, cross-correlation can be used for EEG and EMG signals, respectively. This fact allows the provision of ergonomic information about a subject according to recorded signals. Owing to improvements in artificial intelligence methods and tools, it is possible to improve the quality of this information and to draw conclusions that would not be possible by using standard deterministic models.

## CONCLUSION

Modern organizations strive to improve traditional workstations where workers perform repetitive, monotonous, and tedious assembly activities and to improve the safety and health of operators performing these activities by reducing work injuries and occupational diseases and improving physical and psychological health and worker satisfaction. The improvement of traditional workstations poses a major challenge for modern industrial systems.

Performance of repetitive manual assembly activities at traditional non-ergonomically designed workstations is widespread in many modern manufacturing systems.

This paper presented the results of monitoring the muscle and brain activity of respondents who perform assembly activities for a long period of time in an improper body position, in order to determine the ergonomic risks to the workers are exposed to.

It can be concluded that it is possible to use EEG and EMG signals for the purpose of classification and connection with ergonomic performance. The next step in the research should be to create a data set of signals for both sessions of the experiment and then develop a model for predicting the ergonomic characteristics of a specific subject, which will be a part of future research.

It can also be concluded that the appearance of mental fatigue and a decrease in concentration in all three subjects occurred during the second session, which coincides with the answers by the subjects in the oral interview, which was conducted immediately after the experiment. During the interview, the respondents stated that they began to feel mental fatigue and a decrease in concentration during the second session, more precisely in the middle of the second session.

On the basis of the data obtained using EEG and EMG, a new collaborative workstation was proposed in which a poka-yoke device was installed. The new workstation is aligned with ergonomic and lean principles and is adapted to the individual characteristics, capabilities, skills, and limitations of the operator. At the proposed workstation, workers will perform activities within the golden zone where, on the one hand, their productivity and efficiency are at the highest and, on the other hand, occupational diseases and injuries are reduced to a

minimum due to the elimination of unnecessary bending and stretching of the worker's body.

## REFERENCES

- Antonenko, P.D., Paas, F., Grabner, R.H., & Gog, T.V. (2010). Using Electroencephalography to Measure Cognitive Load. *Educational Psychology Review*, 22, 425-438.
- Barr, A.E., Barbe, M.F., & Clark, B.D. (2004). Work-related musculoskeletal disorders of the hand and wrist: epidemiology, pathophysiology, and sensorimotor changes. *The Journal of orthopaedic and sports physical therapy*, 34 10, 610-27.
- Bakshi, V.K. (2018). Towards Practical Driver Cognitive Workload Monitoring via Electroencephalography.
- Bennie, K. J., Ciriello, V. M., Johnson, P. W., Dennerlein, J. T. (2002). Electromyographic activity of the human extensor carpi ulnaris muscle changes with exposure to repetitive ulnar deviation. *European Journal of Applied Physiology*, 88(1-2), 5-12.
- Björklund, M., Crenshaw, A. G., Djupsjöbacka, M., Johansson, H. (2000). Position sense acuity is diminished following repetitive low-intensity work to fatigue in a simulated occupational setting. *European journal of applied physiology*, 81(5), 361-370.
- Bosch, T., de Looze, M. P., van Dieën, J. H., (2007). Development of fatigue and discomfort in the upper trapezius muscle during light manual work. *Ergonomics*, 50(2), 161-177.
- Brookings, J.B., Wilson, G.F., & Swain, C.R. (1996). Psychophysiological responses to changes in workload during simulated air traffic control. *Biological Psychology*, 42, 361-377.
- Brouwer, A., Zander, T.O., van Erp, J.B., Korteling, J.E., & Bronkhorst, A.W. (2015). Using neurophysiological signals that reflect cognitive or affective state: six recommendations to avoid common pitfalls. *Frontiers in Neuroscience*, 9.
- Charles, R., Nixon, J. (2019). Measuring mental workload using physiological measures: A systematic review. *Applied ergonomics*, 74, 221-232.
- Cimino, A., Curcio, D., Longo, F., & Mirabelli, G. (2009). Improving workers' conditions within industrial workstations.
- De Luca, C. J. (1997). The use of surface electromyography in biomechanics. In *Journal of Applied Biomechanics*, 13(2), 135-163.
- Dingwell, J.B., Joubert, J. E., Diefenthaler, F., Trinity J. D. (2008) Changes in muscle activity and kinematics of highly trained cyclists during fatigue, *IEEE Trans. Biomed. Eng.* 55, 2666-2674.
- Ellegast, R. Assessment of Physical Workloads to Prevent Work-Related MSDs; Institute for Occupational Safety and Health of the German Social Accident Insurance: Berlin, Germany, 2016.
- Fasth-Berglund Å., Stahre J. (2013), Cognitive automation strategy for reconfigurable and sustainable assembly systems, *Assem. Autom.*, vol 33, pp. 294-303.
- Finnsgård, C., Medbo, L., Wänström, C., Neumann, W.P., (2008). The impact of materials exposure on the conditions at the workstation

- Fish, L.A., Drury, C.G., & Helander, M.G. (1997). Operator-specific model: An assembly time prediction model. *Human Factors and Ergonomics in Manufacturing & Service Industries*, 7, 211-235.
- Fisherl, C.D. (1993). Boredom at Work: A Neglected Concept. *Human Relations*, 46, 395 - 417.
- Foong, R., Ang, K.K., Zhang, Z., & Quek, C. (2019). An iterative cross-subject negative-unlabeled learning algorithm for quantifying passive fatigue. *Journal of Neural Engineering*, 16.
- Freitas, R.C., Alves, R.L., Filho, A.G., Souza, R.E., Bezerra, B.L., & Santos, W.P. (2019). Electromyography-controlled car: A proof of concept based on surface electromyography, Extreme Learning Machines and low-cost open hardware. *Comput. Electr. Eng.*, 73, 167-179.
- Garcés Correa, A., Orosco, L., & Laciari, E. (2014). Automatic detection of drowsiness in EEG records based on multimodal analysis. *Medical engineering & physics*, 36 2, 244-9.
- Gerr, F., Fethke, N.B., Anton, D., Merlino, L., Rosecrance, J., Marcus, M., & Jones, M.P. (2014). A Prospective Study of Musculoskeletal Outcomes among Manufacturing Workers. *Human Factors: The Journal of Human Factors and Ergonomics Society*, 56, 178 - 190.
- Gevins, A.S., Leong, H.M., Du, R., Smith, M.E., Le, J., DuRousseau, D.R., Zhang, J., & Libove, J. (1995). Towards measurement of brain function in operational environments. *Biological Psychology*, 40, 169-186.
- Gramann, K., Gwin, J.T., Ferris, D.P., Oie, K.S., Jung, T., Lin, C., Liao, L., & Makeig, S. (2011). Cognition in action: imaging brain/body dynamics in mobile humans. *Reviews in the neurosciences*.
- Hanson, R., Brolin, A. (2011). A comparison of kitting and continuous supply in in-plant materials supply. *International Journal of Production Research*, 51, 979 - 992.
- Hansson, G., Balogh, I., Ohlsson, K., Pålsson, B., Rylander, L., & Skerfving, S. (2000). Impact of physical exposure on neck and upper limb disorders in female workers. *Applied ergonomics*, 31 3, 301-10.
- He, J., Zhu, X., Combining Improved Gray-Level Co-Occurrence Matrix With High Density Grid for Myoelectric Control Robustness to Electrode Shift (2017). *IEEE Trans. Neural Syst. Rehabil.*, 25, 1539-1548.
- Hohnsbein, J., Falkenstein, M., & Hoonmann, J. (1998). Performance differences in reaction tasks are reflected in event-related brain potentials (ERPs). *Ergonomics*, 41 5, 622-33.
- Infantolino, Z.P., Miller, G.A. (2014). Psychophysiological Methods in Neuroscience.
- Jones, T., & Kumar, S. (2004). Six years of injuries and accidents in the sawmill industry of Alberta. *International Journal of Industrial Ergonomics*, 33(5), 415-427.
- Jung, T., Makeig, S. (1994). Estimating level of alertness from EEG. *Proceedings of 16th Annual International Conference of the IEEE Engineering in Medicine and Biology Society*, 2, 1103-1104 vol.2.
- Leider, P.C., Boschman, J.S., Frings-Dresen, M.H., & van der Molen, H.F. (2015). Effects of job rotation on musculoskeletal complaints and related work exposures: a systematic literature review. *Ergonomics*, 58, 18 - 32.
- Lindblom, J., Thorvald, P. (2014). Towards a framework for reducing cognitive load in manufacturing personnel.
- Maakip, I., Keegel, T., & Oakman, J. (2017). Predictors of musculoskeletal discomfort: A cross-cultural comparison between Malaysian and Australian office workers. *Applied ergonomics*, 60, 52-57.
- Matos, M., & Arezes, P.M. (2015). Ergonomic Evaluation of Office Workplaces with Rapid Office Strain Assessment (ROSA). *Procedia Manufacturing*, 3, 4689-4694.
- Mehta, R.K. (2016). Integrating Physical and Cognitive Ergonomics. *IIE Transactions on Occupational Ergonomics and Human Factors*, 4, 83 - 87.
- Mijović P., Ković V., Mačuzić I., Todorović P., Jeremić B., Milovanović M., Gligorijević I. (2015), Do Micro-Breaks Increase the Attention Level of an Assembly Worker? An ERP Study, *Procedia Manufacturing*, 3, pp. 5074-5080.
- Mijović P., Ković V., De Vos M., Mačuzić I., Todorović P., Jeremić B., Gligorijević I. (2016), Towards Continuous and Real-Time Attention Monitoring at Work: Reaction Time versus Brain Response. *Ergonomics*, pp. 1-41.
- Molinari, F., Knaflitz, M., Bonato, P., Actis, M. V. (2006), Electrical manifestations of muscle fatigue during concentric and eccentric isokinetic knee flexion-extension movements. *IEEE Trans. Biomed. Eng.* 53, 1309-13016.
- Parasuraman, R. (2003). Neuroergonomics: Research and practice. *Theoretical Issues in Ergonomics Science*, 4, 20 - 5.
- Rabby K. M., Khan M., Karimodini A., Jiang S. X. (2019), An Effective Model for Human Cognitive Performance within a Human Robot Collaboration Framework, Proceedings of the 2019 IEEE International Conference on Systems, Man and Cybernetics (SMC), Bari, Italy, pp. 3872-3877.
- Savković, M., Caiazza, C., DJapan, M., Vukićević, A. M., Pušica M, Mačuzić, I. (2022), Development of Modular and Adaptive Laboratory Set-Up for Neuroergonomic and Human-Robot Interaction Research. *Front Neurobot.*
- Scalera L., Giusti A., Vidoni R., Di Cosmo V., Matt D. T., Riedl M. (2020), Application of dynamically scaled safety zones based on the ISO/TS 15066:2016 for collaborative robotics, *Int. J. Mech. Control*, vol. 21, pp. 41-49.
- Spath, D., Braun, M. (2021). HUMAN FACTORS AND ERGONOMICS IN DIGITAL MANUFACTURING. *Handbook of Human Factors and Ergonomics*.
- Wiegmann, D.A., Shappell, S. (2001). A Human Error Analysis of Commercial Aviation Accidents Using the Human Factors Analysis and Classification System (HFACS).
- Zhang, X., Li, J., Liu, Y., Zhang, Z., Wang, Z., Luo, D., Zhou, X., Zhu, M., Salman, W., Hu, G., & Wang, C. (2017). Design of a Fatigue Detection System for High-Speed Trains Based on Driver Vigilance Using a Wireless Wearable EEG. *Sensors (Basel, Switzerland)*, 17.

## **ACKNOWLEDGEMENTS**

This research paper has been financed by the European Union's H2020 research project under the Marie Skłodowska-Curie Actions Training Network Collaborative Intelligence for Safety Critical Systems (Grant Agreement ID: 955901).

## **BIOGRAPHY of the first author**

**Marija Savković** was born in Kragujevac, Serbia, in 1984. She graduated from the Faculty of organized sciences at the University of Belgrade. She is currently a Ph.D. student at the Faculty of Engineering, University of Kragujevac.



Her main areas of research include workplace safety, human-robot collaboration, safety 4.0, lean management, ergonomics, quality management, etc. She is currently working as a researcher at the Faculty of Engineering, University of Kragujevac.



VLADAN IVANOVIĆ<sup>1</sup>  
JASMINA MADŽGALJ<sup>2</sup>  
OLGICA MILOŠEVIĆ<sup>3</sup>

## SUSTAINABLE DEVELOPMENT GOALS USED FOR BALANCING SOCIAL, ECONOMIC AND ENVIRONMENTAL SUSTAINABILITY

<sup>1</sup>Ministry of Interior – Sector for  
Emergency Management

<sup>2</sup>Belgrade City Government

<sup>3</sup>Faculty of Applied Management,  
Economics and Finance in Belgrade

<sup>1</sup>ivvladan@yahoo.com

<sup>2</sup>jasmina.madzgalj@beograd.gov.rs

<sup>3</sup>olgica.milosevic@mef.edu.rs

**Abstract:** *The imbalance between human development and ecological limits has exposed growing environmental problems and possible consequences with disastrous proportions. The consequences of these factors are manifested in various environmental problems, ecosystem disturbances, global climate change, natural disasters, hunger and poverty, and many other negative consequences. This paper presents the concept of sustainability and sustainable development, citing and analyzing 17 goals of sustainable development. Sustainability is a characteristic of a process or a state that can be maintained at a certain level without a limitation period, whose aim is to create and maintain the conditions under which people and nature can exist in productive harmony to support current and future generations. Sustainable development emphasizes the need to achieve further economic growth in an environmentally sound manner, given that former patterns of economic development have serious implications for the global environment. The aim of the paper is to demonstrate scientifically that, in order to achieve sustainable development, it is necessary to create a sustainable and more economical economy that respects the ecological principles and the natural environment and to achieve sustainable development goals that recognize that extreme poverty is inseparable from the strategies that increase economic growth and address a range of social needs, including education, health, social protection and employment opportunities, while fighting against climate change and for environmental protection. The paper also presents a GG-GE-SD model of the mutual relationship between green economy, green development and sustainable development, including their mutual functioning.*

**Key words:** sustainable development, sustainable development goals, green economy, green growth, GG-GE-SD model.

## INTRODUCTION

One of the basic concepts of economics of natural resources and the environment is the concept of sustainability, or sustainable development. Despite the various interpretations that can be found in the literature, this concept today has a central place in the consideration of the long-term perspectives of the survival and progress of mankind (Gašić & Ivanović, 2018).

Sustainability, or sustainable development, appears as an essential prerequisite and as the ultimate goal of effective organization of numerous human activities on Earth. The concept of sustainability has become significant in making decisions at different levels of society, considering that we are facing environmental problems such as climate change and loss of biodiversity, but also problems such as poverty, health, etc. (Finnveden & Gunnarsson-Östling, 2016). In times

of crisis, it is important to provide timely information in order to overcome the given situation and to establish the main function of the sustainable development system.

The word sustainable was derived from the Latin term "sustenire" which means "to uphold" (Daly, 1996). In English, this word (sustainable) has been used since 1290, but the etymological significance of the word itself is related to interesting, as well as important, implications related to its use. According to De Vries, "maintaining" can mean "supporting the desired state of something," but also "to withstand an unwanted condition" (De Vries, 1989; Milutinović, 2012). The verb "maintain" carries with it the connotation of the passive, unlike the adjective "sustainable", which implies the active connotation. "Sustainability" is a term that emerged within ecology, signifying an ecosystem's ability to maintain a certain population over time, and only later, with the addition of the context of "development" and forming the syntagm



"sustainable development", has the focus of environmental analysis been transferred to society.

The word "sustainable" implies a steady state dynamic and limitations which, it is argued, supports environmental ideals, while the term "development" implies growth, which supports those who believe technology can solve all problems (Weaver & Lawton, 1999; McDonald, 2006). Grant (1999) believes there needs to be a separation of the terms "development" and "growth" in the whole sustainability debate. The term "growing" is deemed as a quantitative change whereas development relates to a qualitative change in a system (Grant, 1999; McDonald, 2006).

Sustainability is based on a simple principle: All we need for survival and prosperity depends, either directly or indirectly, on our natural environment (Madžgalj et al., 2018). Sustainable development is impossible without social justice – there is no growth without proper management of natural resources, on which our economy is dependent (Ivanović & Madžgalj, 2018). Sustainability effort is to create and maintain conditions under which humans and nature can exist in productive harmony to support current and future generations (Ivanović et al., 2015).

The history of the sustainable development concept is closely related to the changing perceptions of environmental intervention, preservation of nature, and development during the last century. Due to climate and technological changes that have led to problems, society is facing the need for radical changes as a result of increasing technological progress and increasing environmental impacts. Therefore, environmental issues need to be systematically addressed in order to find harmony between all subsystems of the economy. Sustainable economic development requires the provision of economic growth and development in terms of environmental protection by providing a bridge between sustainable economic growth, improving human health, social justice, employment and environmental protection.

Understanding of sustainable development has changed over time due to the evolution of ecological and developmental studies that culminated in a widespread recognition that economic and social development must be achieved in an environmentally sound manner.

Agger & Jelsoe (2010) further argue that sustainable development is unthinkable without ethics, which they explicitly state: "without ethics, the demand for sustainable development becomes an unfounded claim. And although there often are arguments for a sustainable development without mentioning ethics, it will stay as a tacit precondition, attracting meaning to the argumentation from the beginning to the end." Sustainable development is an ethical idea based on four ideas. Apart from meeting the needs of the poor and the future generations and the maintenance of natural resources and nature, it should strive for social fairness by working toward a fair distribution of

resources within the global population (social fairness), revitalizing economic growth by producing more with less, and fighting poverty and environmental degradation (sustainable economy) (Noubissie, 2014).

## **CONCEPT OF SUSTAINABILITY AND SUSTAINABLE DEVELOPMENT AND GOALS OF SUSTAINABLE DEVELOPMENT**

The basic significance of sustainability is the possibility of something extending more or less infinitely in the future. Sustainability is therefore a characteristic of a process or a state that can be maintained at a certain level without a limitation period (Milutinović, 2012).

In addition to the previous points of view, sustainability can be viewed from other perspectives (Mladenović, 2017), such as the following:

- A technocentric view is similar to strong sustainability. According to this view, natural resources can be extracted without special restrictions, people are superior to nature, and the economy is isolated from nature and encourages global growth.
- The ecocentric view is more similar to weak sustainability. This view regards the earth as lively, fragile and sensitive to human actions, and a place where the human population has already reached its maximum.
- Sustainable-centric view attempts to reconcile the previous two. Its basic characteristics are that the earth and people are connected in a single system, the population has to be stabilized, while the economy and the ecological system are supported.

Sustainable Development first appeared in the Environmental Strategy, presented by the International Union for Conservation of Nature (IUCN) in 1980, where economic growth was seen as an enemy of the environment (Stern et al., 2017). However, the biggest emphasis on sustainable development was placed in the Brundtland Report (WCED, 1987), in which sustainable development is defined as "a development that meets the needs of the present generation while allowing future generations to meet their needs." Since then, the concept of sustainable development has been used in major international agreements, where four recurring principles are considered to be associated with the concept (Sands & Jacqueline, 2012):

1. The principle of intergenerational equity: the need to preserve natural resources for future generations.
2. Sustainable use principle: exploitation of natural resources aimed at long-term availability and taking into account the environmental impact.
3. The principle of capital intergeneration: countries should use natural resources according to the needs of other countries.

4. Principle of integration: development plans and projects should integrate environmental issues.

One aspect of the Brundtland report was the use of a sustainable development concept that would call into question a development model based on a high rate of resource reduction for the continuation of economic growth. However, it also supported rapid economic growth, resulting in an ambiguity that allowed governments, corporations and organizations to have different interpretations of the concept. Therefore, sustainable development is also called environmental protection, social equity and economic growth as an equal sphere, or – dependent on interest. Thus, the concept of sustainable development and sustainability is used to describe many types of policies, from the expansion of the coal industry to the protection of natural areas (eco-union, MIO-ECSDE, GEC, 2016).

In the past few years, economists have made progress in articulating the concept of sustainable development. Of crucial importance is the fact that scientists synthesized sustainable development as based on three pillars: economic development, social equity and environmental protection (United Nations, 2007; Oladeji, 2014; Ekperiware et al., 2017).

The Sustainable Development Goals (SDGs) of the “2030 Agenda for Sustainable Development” are a United Nations initiative that builds on the partially achieved Millennium Development Goals (MDGs). While the 2012 Rio+20 Summit embraced the concept of Green Economy as one of the important tools to achieve sustainable development, it also agreed that specific goals and targets for all countries should be developed in order to achieve Sustainable Development (eco-union, MIO-ECSDE, GEC, 2016).

On 25 September 2015, the entire UN General Assembly adopted the 17 goals and 169 targets that comprise the SDGs to be achieved by 2030. The SDGs “recognize that ending poverty must go hand-in-hand with strategies that build economic growth and addresses a range of social needs including education, health, social protection, and job opportunities, while tackling climate change and environmental protection.” The SDGs are to be achieved by the adoption of Green Economy policies at the national level and active participation of the private sector in supporting Green Economy (eco-union, MIO-ECSDE, GEC, 2016).

#### **17 Sustainable Development Goals (UN, 2015):**

**SDG 1** – End poverty in all its forms everywhere;

**SDG 2** – End hunger, achieve food security and improved nutrition and promote sustainable agriculture;

**SDG 3** – Ensure healthy lives and promote well-being for all at all ages;

**SDG 4** – Ensure inclusive and equitable quality education and promote lifelong learning opportunities for all;

**SDG 5** – Achieve gender equality and empower all

women and girls;

**SDG 6** – Ensure availability and sustainable management of water and sanitation for all;

**SDG 7** – Ensure access to affordable, reliable, sustainable and modern energy for all;

**SDG 8** – Promote sustained, inclusive and sustainable economic growth, full and productive employment and decent work for all;

**SDG 9** – Build resilient infrastructure, promote inclusive and sustainable industrialization and foster innovation;

**SDG 10** – Reduce inequality within and among countries;

**SDG 11** – Make cities and human settlements inclusive, safe, resilient and sustainable;

**SDG 12** – Ensure sustainable consumption and production patterns;

**SDG 13** – Take urgent action to combat climate change and its impacts;

**SDG 14** – Conserve and sustainably use the oceans, seas and marine resources for sustainable development;

**SDG 15** – Protect, restore and promote sustainable use of terrestrial ecosystems, sustainably manage forests, combat desertification, halt and reverse land degradation and halt biodiversity loss;

**SDG 16** – Promote peaceful and inclusive societies for sustainable development, provide access to justice for all and build effective, accountable and inclusive institutions at all levels;

**SDG 17** – Strengthen the means of implementation and revitalize the global partnership for sustainable development.

These goals will end poverty and hunger, achieve the human rights of all, achieve gender equality and empower all women and girls, and ensure the permanent protection of the planet and its natural resources. They are integrated and indivisible and they balance the three dimensions of sustainable development: economic, social and environmental.

On 1 January 2016, the announced 17 goals of the 2030 Agenda for Sustainable Development officially came into force. Over the next 15 years, these goals will rely on the previous MDGs and complete what they have not achieved.

In Agenda 21, one of the activities in the chapter Scientific and Technological Community points to the need for the development and application of information technology in order to increase the dissemination of information for sustainable development.

## GREEN GROWTH AND GREEN ECONOMY AS SUBCATEGORIES OF SUSTAINABLE DEVELOPMENT

Green growth is needed to achieve global prosperity quickly and in the long term. Climate change, ecosystem degradation and resource depletion threaten the basis of life itself (IPCC, 2014). Growth implies the recognition of ecosystem services, such as adequate access to food and clean water, regulation of climatic conditions and recreational benefits, bearing in mind that these are social values. Green growth challenges conventional indicators of economic performance, such as GDP, which do not provide a good account of performance in green industry, natural capital and ecosystem services (Green Growth Knowledge Platform, 2013).

According to Kasztelan (2017), the parallel functioning of three "green" ideas is not contradictory. On the contrary, complementary and synergistic relations between them can be identified. The starting point for analyzing the connections between these three concepts is the view that sustainability, and therefore sustainable development, is a task that should ultimately be the goal. The primary assumption of the idea of a green economy or green growth does not replace the concept of sustainable development, but the belief that the achievement of sustainable development should be based on an adequately oriented economy is certainly growing. Building a green economy based on the assumptions of the green growth strategy must become an integral element of economic policy on the way to sustainable development.

Sustainable development provides an important context for green growth. Green growth is not intended as a substitute for sustainable development, but should be seen as a means to achieve sustainable development. It is narrower in scope, which implies an operational policy plan that can help achieve concrete, measurable progress at the interface between the economy and the environment. It provides a strong focus on fostering the necessary conditions for innovation, investment and competition that can lead to new sources of economic growth, consistent with resilient ecosystems (OECD, 2011b). Green growth strategies should pay particular attention to the many social and equity issues that may arise as a direct result of the green economy – both nationally and internationally. To achieve this, they should be implemented in parallel with initiatives that address the broader social pillar of sustainable development. The goal of many developing countries is to achieve diverse and sustainable development over time, which leads to poverty reduction, increased well-being and significant improvements in the quality of life of citizens. This is achieved by taking into account the total value of natural capital and recognizing its essential role in economic growth. The green growth model promotes an economical and resource-efficient way of leading a sustainable choice of production and

consumption. Simply put, green growth will help developing countries achieve sustainable development. Green growth should be interpreted as a path or strategy to achieve sustainable development, but with a relatively greater focus on economic growth and environmental activities.

### GG-GE-SD model

The interrelationships between the concepts of green economy, green growth and sustainable development must be viewed from the point of view of common feedbacks. Previous approaches have largely focused on competitive relationships, excluding the mutual functioning of the analyzed concepts. In Figure 1, a complementary and synergistic approach is proposed, which will be achieved by the proposed relationship model: GG (green growth) – GE (green economy) – SD (sustainable development) (Figure 1).

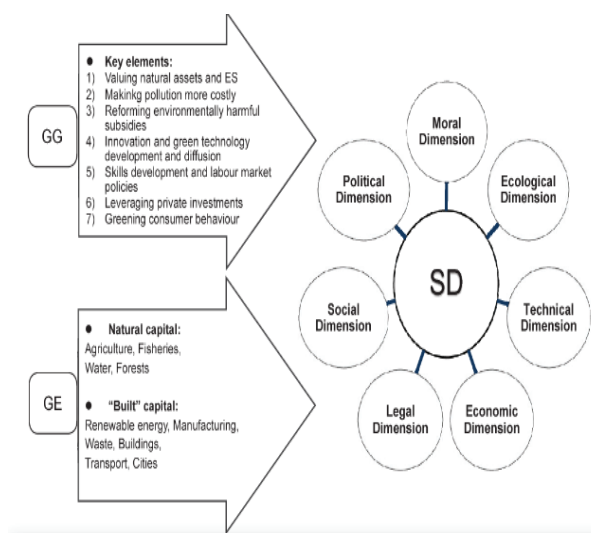


Figure 1. GG-GE-SD model  
Source: Kasztelan, 2017

Sustainable development remained the ultimate purpose of the activities undertaken under this model. So far, no equally good solution has been specified regarding the development of current and future generations; therefore, we should not focus on "why we cannot succeed" but on "what we can do to succeed". Kasztelan (2017) believes that possible solutions in this regard are provided by the assumptions of green growth and green economy. The proposed model of achieving sustainable development (Figure 1), as a starting point, points to a properly prepared green growth strategy (GG). It should be emphasized once again that green growth does not replace sustainable development. On the contrary, it should represent a practical and flexible approach to achieving specific, measurable progress in two key aspects: economic and environmental, fully recognizing the social consequences of greening the growth of the respective economies.

The second element is the green economy (GE). The key here is to identify all areas to "go green". On the one hand, the green economy covers sectors arising from natural capital, e.g. agriculture, fisheries, forests and water management. These sectors have a significant impact on the economy, because they provide the basis for production, but also because the living conditions of the rural population are directly determined by such resources. On the other hand, the green economy also refers to sectors based on the so-called "Human Capital", which are conventionally called the "brown" sectors of the economy. Running a green economy requires changes in production and consumption habits in order to become sustainable, factoring in megatrends, in order to ensure prosperity and a high quality of life both globally and for future generations. The interaction between different groups of players, for example between producers and consumers or between the financial sector and the real economy, plays a major role. This requires interdisciplinary research approaches and, in many cases, means looking beyond individual industry sectors and national borders. Growth in the green economy is driven by investments that reduce pressures on the environment and services and reduce carbon emissions and pollution, while simultaneously improving the energy efficiency of energy and resources and preventing the loss of biodiversity and ecosystem services. The green economy reveals its challenges, namely, to maintain the levels of economic growth and prevent further harm to the environment (Cortés, 2015).

Sectors such as transport, energy and production have a great potential for saving energy and resources. Such savings can also stimulate economic growth and increase employment. Efficient use of resources is a multidimensional issue, as it can relate to energy and material efficiency and improved waste management (Kasztelan, 2017).

## CONCLUSION

Sustainable development promotes economic growth, environmental sustainability and social development in the developed and developing world.

As the current dominant paradigm of development, the principles of sustainable development have been adopted around the world and have a significant impact on international agreements and national policies and strategies. Sustainable development highlights the need to achieve further economic growth in an environmentally sound manner, given that former patterns of economic development have serious implications for the global environment.

Sustainable development is the economic development of a region that is implemented without reducing natural resources. It is necessary to ensure a better quality of life for all, now and in the future, in a fair way within the limits of support for ecosystems.

Sustainable development is the normative outlook of the world, which means it recommends a gathering to which the world should strive. In this normative (or ethical) sense, sustainable development requires a world in which economic progress is widespread; extreme poverty has been eliminated; social trust is spurred by policies that strengthen the community; and the environment is protected from man-caused degradation. Sustainable development recommends a holistic framework in which society aims at economic, social and environmental goals. Sometimes the following terms are used: sustainable development calls for socially inclusive and environmentally sustainable economic growth.

Goals of sustainable development represent a unique political commitment, urging the action of all countries to promote prosperity while protecting the planet. They acknowledge that eradicating poverty is the greatest global challenge and an important condition for sustainable development. To this end, all countries are invited to develop strategies that increase economic growth and address a range of social needs, including education, health, social protection and employment opportunities, while dealing with climate change and environmental protection.

Goals of sustainable development have a non-binding nature, but symbolize an unprecedented opportunity to set the world on a sustainable course and ensure a dignified life for all. Goals of sustainable development are universal and provide a clear political framework for regulatory actions at the national and international levels. It is expected that national governments will establish political plans that are in line with the goals of the 2030 Agenda. In that sense, countries retain a primary duty to monitor and analyze the progress made in implementing the objectives, which will require quality, accessible and timely data collection.

The vision of a green economy is an internationally competitive economy that is both environmentally and socially compatible. This concept creates a real link between ecology and economy, and the green economy increases social protection and the fight against poverty, striving for social justice. In light of the recognized environmental constraints, the goal is to achieve environmentally acceptable, qualitative and therefore sustainable growth, based on a comprehensive understanding of the interrelationships between economics, finance and politics. The ultimate goal is the development of diverse and sustainable models of production and consumption that ensure prosperity and a high quality of life throughout the world, especially for future generations.

"Greening" the economy can create consistent and positive effects such as increased wealth, increased economic output, decent work and poverty reduction. In the economic dimension, green economy and green growth should enable the overall growth of well-being; in the social dimension, they will influence the

improvement of the quality of life, while in the ecological dimension, they will help reduce the pressure on the environment and improve the efficiency of how natural capital is used. A properly designed green growth strategy, combined with a comprehensive "greening" of the economy, will help to permanently approach the path of sustainable development.

## REFERENCES

- Agger, P. and Jelsoe, E. (2010). *Sustainability, biodiversity and ethical aspects of the deliberate release of GMOs*, In: Figueroa, Elling, Jelsoe and Nielsen (eds) (2010): A new agenda for sustainability, Farnham, Surrey, GBR, Ashgate Publishing Group.
- Baker, S. (2006). *Sustainable Development*. London: Routledge.
- Barbier E.B. and Burgess J. C. (2017). *The Sustainable Development Goals and the systems approach to sustainability, Economics: The Open-Access, Open-Assessment E-Journal* 11 (2017–28), <http://dx.doi.org/10.5018/economics-ejournal.ja.2017-28> (03.06.2018.).
- Barbier, E. B. (1987). *The concept of sustainable economic development. Environmental Conservation*, <https://www.cambridge.org/core/journals/environmental-conservation/article/concept-of-sustainable-economic-development/33A3CD3BD12DE8D5B2FF466701A14B4A> (02.06.2018.).
- Battaglia, M., Bianchi, L., Frey, M. and Iraldo, F. (2010), "An innovative model to promote CSR among SMEs operating in industrial clusters: Evidence from an EU project", *Corporate Social Responsibility and Environmental Management*, Vol. 17 No. 3, pp. 133-141.
- Brundtland, G., et al (1987). "Our Common Future." *The World Commission on Environment and Development*. Oxford: Oxford University Press.
- Costanza, R., Daly, L., Fioramonti, L., Giovannini, E., Kubiszewskia, I., Mortensen, L.F., Pickett, K.E., Ragnarsdottir, K., De Vogli, R., Wilkinson, R. (2016). *Modelling and measuring sustainable wellbeing in connection with the UN Sustainable development Goals. Ecological Economics* 130:350–355. <http://www.sciencedirect.com/science/article/pii/S0921800915303359>.
- Cortés, P. (2015) The external impact of the Green Economy – An analysis of the environmental implications of the Green Economy, <http://hdl.handle.net/10419/120878>.
- Crespo, B., Míguez-Álvarez, C., Arce, M.E., Cuevas, M. ID and Míguez J. L. (2017). *The Sustainable Development Goals: An Experience on Higher Education*, *Sustainability* 2017, 9, 1353; doi:10.3390/su9081353, [www.mdpi.com/2071-1050/9/8/1353/pdf](http://www.mdpi.com/2071-1050/9/8/1353/pdf) (02.06.2018.).
- Daly, H. (1996). *Beyond Growth: The Economics of Sustainable Development*. Boston, MA: Beacon Press.
- De Vries, H. (1989). "Sustainable resource use. An enquiry into modeling and planning". Ph.D. Dissertation, Univ. Groningen.
- Department of Environment, Community and Local Government, (2012). Our sustainable future. A framework for sustainable development for Ireland, Department of Environment, Community and Local Government, Ireland, p.116.
- Economic Commission for Latin America and the Caribbean (2001). "Financiamiento para el desarrollo ambientalmente sostenible", document prepared for the Regional Preparatory Conference of Latin America and the Caribbean for the World Summit on Sustainable Development, September, forthcoming.
- Eco-union, MIO-ECSDE, GEC (2016). Towards a Green Economy in the Mediterranean, Assessment of National Green Economy and Sustainable Development Strategies in Mediterranean Countries. *eco-union, the Mediterranean Information Office for Environment, Culture and Sustainable Development (MIO-ECSDE) and the Green Economy Coalition (GEC)* within the framework of a project funded by the *MAVA Foundation*.
- Ekins, P. A. (1994). The Environmental Sustainability of Economic Processes: A Framework for Analysis. Chapter 2 in J.C.J.M. van den Bergh and J. van der Straaten, eds. *Toward Sustainable Development: Concepts, Methods, and Policy*. Island Press, Washington, D.C., pp. 25–56.
- Ekperiware, M., Timothy O. Olatayo, and Abiodun A. Egbetokun (2017). Human capital and sustainable development in Nigeria: How can economic growth suffice environmental degradation? *Economics Discussion Papers*, No 2017-29, Kiel Institute for the World Economy.
- Ekperiware, M.C., Olatayo, T.O., Egbetokun, A.A. (2017). Human capital and sustainable development in Nigeria: How can economic growth suffice environmental degradation?, *Economics Discussion Papers*, No. 2017-29.
- Elliott, J. A. (2006). *An Introduction to Sustainable Development*, 3<sup>rd</sup> ed. Routledge, London and New York.
- Figueroa, Elling, Jelsoe and Nielsen (eds) (2010). A new agenda for sustainability, Farnham, Surrey, GBR, Ashgate Publishing Group.
- Finnveden, G. and Gunnarsson-Östling, U. (2016). *Sustainable development goals for cities*, Paper for the JPI Urban Europe Symposium "Shaping common ground in urban sustainability?" in Brussels 2016-10-27 Forum for the future (2011). Available at: <http://www.forumforthefuture.org/whatis-sd> (04.03.2018).



- Gašić, M. and Ivanović, V. (2018). Rural Tourism in Serbia and Impact on Economic and Social Development, 3<sup>rd</sup> International Thematic Monograph, Modern management tools and economy of tourism sector in present era, UDEKOM BALKAN, Association of Economists and Managers of the Balkans, Belgrade (in press).
- Grant, M. (1999). Tourism development. *Annals of Tourism Research*, 26(1), 235-237.
- Green Growth Knowledge Platform (2013). Moving towards a Common Approach on Green Growth Indicators, Green Growth Knowledge Platform Scoping Paper.
- Harris, J. (2001). *Basic Principles of Sustainable Development*, Tufts University Medford MA 02155, USA, <http://ase.tufts.edu/gdae> (10.03.2018).
- IPCC (2014). Climate Change 2014 – Mitigation and Climate change. Geneva, Switzerland, Intergovernmental Panel on Climate Change.
- Ivanović, V. and Madžgalj, J. (2018). *GREEN TOURISM AS PART OF THE GREEN ECONOMY IN THE FUNCTION OF FUTURE SUSTAINABILITY IN TOURISM*, International Monograph CHALLENGES OF GREEN ECONOMY, Faculty of Business Studies and Law, University „Union – Nikola Tesla” Belgrade, Faculty of Strategic and Operational Management University „Union – Nikola Tesla” Belgrade, Scientific Professional Society for Environmental Protection of Serbia ECOLOGICA, pp. 195-216.
- Ivanović, V., Gašić, M., Plavski, J., Madžgalj, J. (2015). *Nature as the basis of green economy*, Scientific-professional society for environmental protection of Serbia – Ecologica. Vol. 22, No 78, p. 329-33.
- Kasztelan, A. (2017). Green growth, green economy and sustainable development: Terminological and relational discourse, *Prague Economic Papers*, 2017, 26(4), 487-499.
- Leal Filho, W. (2011). "Editorial", *International Journal of Climate Change Strategies and Management*, Vol. 3 Issue: 3.
- Madžgalj, J., Gašić, M. and Ivanović, V. (2018). *Ecological Policy of Serbia and the European Union*, Featured Thematic Collection of Works of Leading National Importance “Eastern Europe and Postmodern Challenges”, Center for Strategic Research on National Security CESNA B, Belgrade in cooperation with the Faculty of Law, Security and Management "Konstantin Veliki" University of Niš, and Union Nikola Tesla University Belgrade.
- McDonald, J. R. (2006). *Understanding sustainable tourism development from a complex systems perspective: a case study of the Swan River, Western Australia*. Retrieved from <http://ro.ecu.edu.au/theses/82>.
- Meyer, B., Milewski, D. (2009) *Strategie rozwoju turystyki w regionie*. Wydawnictwo Naukowe PWN.
- Milutinović, S. (2012). "Relationship between Sustainability and Sustainable Development". *THEMES*, Year XXXVI, No. 2, p. 596-613.
- Mladenović, S., (2017). *Sustainability and sustainable development in retail - international and domestic experiences*, "Ekonomika" Niš, Vol. 1, No. 1, pp. 47-55.
- Munplanet, <http://www.munplanet.com/> (12.03.2018).
- Noubissié, D.T. (2014). *The concept of Sustainable Development and Sustainable Management of Natural Resources in Africa through the German Development Cooperation, Case Study: Benin, Cameroon Namibia*, Justus-Liebig Universität Gießen Fachbereich 07: Mathematik, Physik und Geographie Institut für Geographie.
- OECD (2011b). *Towards Green Growth*, Paris: Organization for Economic Cooperation and Development.
- Oladeji S. I. (2014). *Educated and Qualified, but Jobless: A Challenge for Sustainable Development*, 262 Obafemi Awolowo University (OAU) Inaugural Lecture Series, Economic Department, OAU, Ile-Ife, Osun State, Nigeria.
- Pawłowski, A. (2006). Wielowymiarowość Rozwoju Zrównoważonego. *Problemy Ekorozwoju/Problems of Sustainable Development*, 1 (1), 23-32.
- Pezzey, J. and M.A. Toman (2002). *The Economics of Sustainability: A Review of Journal Articles*. Discussion Paper 02-03. Resources for the Future, Washington, D.C., January 2002. <http://www.rff.org/RFF/documents/RFF-DP-02-03.pdf> (02.06.2018.).
- Sands, P. and Jacqueline P. (2012). *Principles of International Environmental Law*. Cambridge University Press.
- Stappen, R. K. (2008). *A Sustainable World is Possible. Problemlösungen für das 21. Jahrhundert mit dem Wise-Consensus Verfahren*. Available at: <http://www.faaape.org/wise-consensus-4-2008.pdf> (15.02.2018).
- Stern, D. I., Common, M. S., and Barbier, E. B. (2017). *Economic Growth and Environmental Degradation: The Environmental Kuznets Curve and Sustainable Development*, World Development, Vol. 24, No. 7, pp. 1151-1160, 1996.
- UNESCO (2005). *Sustainable Development*, United Nations Educational, Scientific and Cultural Organization, France.
- United Nations (2007). *Indicators of Sustainable Development: Guidelines and Methodologies*, United Nations publication, Sales No. E.08.II.A.2, ISBN 978-92-1-104577-2, Copyright © United Nations, 2007, All

rights reserved, Printed by the United Nations, New York, Third Edition, <http://www.un.org/esa/sustdev/> (12.03.2018).

WCED (World Commission on Environment and Development), (1987). *Our Common Future*, Oxford University Press, Oxford

Weaver, D., & Lawton, L. (1999). *Sustainable tourism: a critical analysis*. Gold Coast: CRC for Sustainable Tourism.

## **BIOGRAPHY**

Vladan Ivanović was born in Niš, Serbia, in 1984.

He works in the Emergency Management Administration in Niš, and since December 2017 he has been working as an Assistant Professor at the University Business Academy in Novi Sad.

He is intensively engaged in scientific research and has published over 60 scientific and professional papers in Serbia and abroad

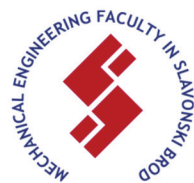




Република Србија

Министарство просвете,  
науке и технолошког развоја

**U. PORTO**  
**FEUP** FACULDADE DE ENGENHARIA  
UNIVERSIDADE DO PORTO



ISBN 978-86-6093-112-4